

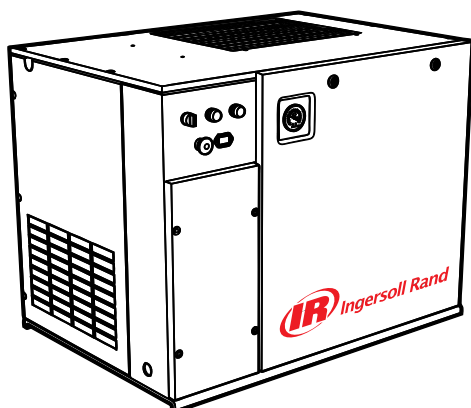

Contact-Cooled Rotary Screw Air Compressor

UP5 4, UP5 5, UP5 7, UP5 11c
UP6 5, UP6 7, UP6 10, UP6 15c



Installation, Operation and Maintenance

- EN Installation, Operation and Maintenance
- ES Instalación, operación y mantenimiento
- FR Installation, exploitation et maintenance
- PT Instalação, operação e manutenção



Save These Instructions



CONTENTS

FOREWORD	3	AIR FILTER ELEMENT CHANGE PROCEDURE	11
SAFETY	4	SEPARATOR ELEMENT CHANGE PROCEDURE.....	11
INSTALLATION / HANDLING	5	COOLER CLEANING PROCEDURE	11
LOCATION IN THE PLANT	5	BELT CHECKING AND ADJUSTMENT PROCEDURE	11
DISCHARGE PIPING.....	5	ELECTRIC DRAIN VALVE.....	12
ELECTRICAL DATA	5	MOISTURE SEPARATOR MAINTENANCE	13
OPERATING INSTRUCTIONS	6	AIR FILTER MAINTENANCE.....	13
GENERAL OPERATION	6	DISASSEMBLING THE UNIT.....	14
COMPRESSOR CONTROLS	6	REFRIGERANT LEAKS IN THE REFRIGERATION CIRCUIT	14
PRIOR TO STARTING	8	REFRIGERANT CHARGING	14
STARTING	8	CHARACTERISTICS OF REFRIGERANT R134A	14
NORMAL/EMERGENCY STOPPING	8	TROUBLESHOOTING.....	14
MAINTENANCE	9	MAINTENANCE.....	14
MAINTENANCE SCHEDULE	9	TROUBLE SHOOTING	15
ROUTINE MAINTENANCE	9		
TOP UP COOLANT PROCEDURE.....	10		
COOLANT CHANGE PROCEDURE	10		
COOLANT FILTER CHANGE PROCEDURE	10		

FOREWORD

The contents of this manual are considered to be proprietary and confidential to **Ingersoll Rand** and should not be reproduced without the prior written permission of **Ingersoll Rand**.

Nothing contained in this document is intended to extend any promise, warranty or representation, expressed or implied, regarding the **Ingersoll Rand** products described herein. Any such warranties or other terms and conditions of sale of products shall be in accordance with the standard terms and conditions of sale for such products, which are available upon request.

This manual contains instructions and technical data to cover routine operation and scheduled maintenance tasks by operation and maintenance staff. Major overhauls are outside the scope of this manual and should be referred to an authorised **Ingersoll Rand** service department.

Any modification to any part is absolutely prohibited and would result in the CE certification and marking being rendered invalid.

All components, accessories, pipes and connectors added to the compressed air system should be:

- of good quality, procured from a reputable manufacturer and, wherever possible, be of a type approved by **Ingersoll Rand**.
- clearly rated for a pressure at least equal to the machine maximum allowable working pressure.
- compatible with the compressor lubricant/coolant.
- accompanied with instructions for safe installation, operation and maintenance.

*Details of approved equipment are available from **Ingersoll Rand** Service departments.*

The use of non-genuine spare repair parts other than those included within the **Ingersoll Rand** approved parts list may create hazardous conditions over which **Ingersoll Rand** has no control. Therefore **Ingersoll Rand** does not accept any liability for losses caused by equipment in which non-approved repair parts are installed. Standard warranty conditions may be affected.

Ingersoll Rand reserves the right to make changes and improvements to products without notice and without incurring any obligation to make such changes or add such improvements to products sold previously.

The intended uses of this machine are outlined below and examples of unapproved usage are also given, however **Ingersoll Rand** cannot anticipate every application or work situation that may arise.

IF IN DOUBT CONSULT SUPERVISION.

This machine has been designed and supplied for use only in the following specified conditions and applications:

- Compression of normal ambient air containing no known or detectable additional gases, vapors or particles.
- Operation within the ambient temperature range specified in the *PRODUCT SPECIFICATION SHEET*.

The use of the machine in any of the situation types listed in table 1:–

- Is not approved by Ingersoll Rand,**
- May impair the safety of users and other persons, and**
- May prejudice any claims made against Ingersoll Rand.**

TABLE 1

Use of the machine to produce compressed air for: <ol style="list-style-type: none"> direct human consumption indirect human consumption, without suitable filtration and purity checks
Use of the machine outside the ambient temperature range specified in the <i>PRODUCT SPECIFICATION SHEET</i> .
Use of the machine where there is any actual or foreseeable risk of hazardous levels of flammable gases or vapors. THIS MACHINE IS NOT INTENDED AND MUST NOT BE USED IN POTENTIALLY EXPLOSIVE ATMOSPHERES, INCLUDING SITUATIONS WHERE FLAMMABLE GASES OR VAPOURS MAY BE PRESENT.
Use of the machine fitted with non Ingersoll Rand approved components.
Use of the machine with safety or control components missing or disabled.

The company accepts no responsibility for errors in translation of this manual from the original English version.

SAFETY

Locate, read, understand and follow all Danger, Warning, Caution, and Operating Instructions on the product and in all Manuals. Failure to comply with safety precautions described in the manuals supplied with the product, this manual or any of the labels and tags attached to the product may result in death, serious injury or property damage.

Check that all labels, tags and data (name) plates are in place and legible.

It is your responsibility to make this information available to others.

If you have any questions about safety or procedures not included in this manual, ask your supervisor or contact any **Ingersoll Rand** office or qualified **Ingersoll Rand** distributor.

INSTALLATION / HANDLING

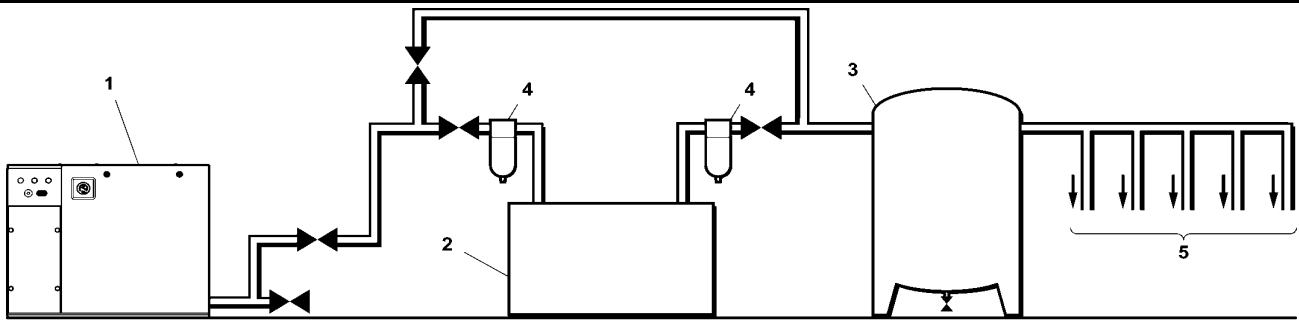

T5973
Revision 00
06/04

KEY
1) Compressor
2) Air Dryer
3) Air Receiver
4) Compressed air filters
5) System demand points

NOTE
Items [2] to [5] are optional or may be existing items of plant. Refer to your Ingersoll Rand distributor / representative for specific recommendations.

LOCATION IN THE PLANT
NOTE
Ensure that the unit is wired for proper voltage before installation.

⚠ CAUTION

The standard compressor unit is not suitable for operation in temperatures liable to cause freezing as condensate water is liable to be produced in the after cooler and receiver where fitted. Refer to your Ingersoll Rand distributor for further information.

DISCHARGE PIPING

Discharge piping should be at least as large as the discharge connection of the compressor. All piping and fittings should be suitably rated for the discharge pressure. It is essential when installing a new compressor [1], to review the total air system. This is to ensure a safe and effective total system. One item which should be considered is liquid carryover. Installation of air dryers [3] is always good practice since properly selected and installed they can reduce any liquid carryover to zero. It is good practice to locate an isolation valve close to the compressor and to install line filters [4]. It is a requirement for air dryers covered under Aircare that correctly sized **Ingersoll Rand** pre and afterfilters are installed.

ELECTRICAL DATA

An independent electrical isolator or disconnect should be installed adjacent to the compressor. Feeder cables/wires should be sized by the customer/ electrical contractor to ensure that the circuit is balanced and not overloaded by other electrical equipment. The length of wiring from a suitable electrical feed point is critical as voltage drops may impair the performance of the compressor. Feeder cables / wires connections to isolator or disconnect should be tight and clean. The applied voltage must be compatible with the motor and compressor data plate ratings. The control circuit transformer has different voltage tapings. Ensure that these are set for the specific applied voltage prior to starting.

The compressor can be installed on any level floor capable of supporting it. A dry, well ventilated area where the atmosphere is clean is recommended. A minimum of 1m (3ft) should be left all around machine for adequate service access and ventilation.

Adequate clearance needs to be allowed around and above the machine to permit safe access for specified maintenance tasks.

Ensure that the machine is positioned securely and on a stable foundation. Any risk of movement should be removed by suitable means, especially to avoid strain on any rigid discharge piping.

⚠ CAUTION

Screw type compressors [1] should not be installed in air systems with reciprocating compressors without means of isolation such as a common receiver tank. It is recommended that both types of compressor be piped to a common receiver using individual air lines.

⚠ CAUTION

The use of plastic bowls on line filters and other plastic air line components can be hazardous. Their safety can be affected by either synthetic coolants or the additives used in mineral oils. Ingersoll Rand recommends that only filters with metal bowls should be used on any pressurised system.

⚠ CAUTION

Never test the insulation resistance of any part of the machines electrical circuits, including the motor without completely disconnecting the electronic controller (where fitted).

⚠ CAUTION

Ensure that the motor rotates in the correct direction as indicated by direction arrows.

OPERATING INSTRUCTIONS

GENERAL OPERATION

The compressor is an electric motor driven, single stage screw compressor, complete with accessories piped, wired and baseplate mounted. It is a totally self contained air compressor package.

The standard compressor is designed to operate in an ambient range of 35.6°F - 104°F (2°C to 40°C). The maximum temperature is applicable up to a maximum elevation of 3280ft (1000m) above sea level. Above this altitude significant reduction in maximum allowable ambient temperature is required.

Compression in the screw type air compressor is created by the meshing of two (male & female) helical rotors.

The air/coolant mixture discharges from the compressor into the separation system. This system removes all but a few PPM of the coolant from the discharge air. The coolant is returned to the cooling system and the air passes through the aftercooler and out of the compressor.

Cooling air is moved through the coolers by the cooling fan and discharged from the machine.

CAUTION

Cooling air is drawn in at the end of the machine package passing through the filter and cooler before being discharged from the top of the machine. Care should be taken to avoid blocking the airflow, or causing any restriction in excess of the maximum backpressure allowed for ducting. Do not direct the airflow at face or eyes.

By cooling the discharge air, much of the water vapour naturally contained in the air is condensed and may be drained from the downstream piping and equipment.

The coolant system consists of a sump, cooler, thermostatic valve and a filter. When the unit is operating, the coolant is pressurized and forced to the compressor bearings.

The compressor load control system is automatic on-off line. This allows the compressor to maintain a set discharge line pressure by varying output capacity to match the system demand. The unit is provided with an automatic stop and restart system for use in plants where the air demand varies sufficiently to allow a compressor to shut down and save power. Significant system volume will assist this and is recommended.

When the compressor is equipped with the optional dryer, the dryer will cycle on and off with the compressor.

WARNING

When the unit stops running as the result of low air demand, normally indicated by auto restart light, it may restart and return to load at any time.

Safety of operation is provided as the compressor will shut down if excessive temperatures or electrical overload conditions should occur.

CAUTION

This unit is not designed or intended to operate when contaminated with silicone. Lubricants, greases or other items containing silicone should not be used on this unit.

CAUTION

LOW DEMAND APPLICATIONS

During periods of low demand, the compressor may not reach its normal operating temperature. Sustained operation at low demand can result in the build up of condensate in the coolant. If this situation occurs, the lubricating characteristics of the coolant can be impaired which may lead to damage of the compressor.

THE COMPRESSOR SHOULD BE ALLOWED AMPLE LOADED RUNNING TIME OF AT LEAST 10 MINUTES PER HOUR DURING NORMAL DAILY USE.

COMPRESSOR CONTROLS

DIRECT ONLINE STARTING:

The compressor is equipped for Automatic Start & Stop Control. When the receiver tank pressure reaches the pressure setting, the control circuit:

- 1) Unloads the compressor and
- 2) Starts a timer – normally set at 6-10min.

The compressor continues to run unloaded while the timer times down. While the timer is timing down, if the pressure switch becomes unsatisfied and calls for more air, then the timer is d-energized and the compressor loads – and the process repeats once the pressure switch is satisfied again.

However, if the pressure switch is still satisfied when the timer times down, then the compressor will shut down completely – waiting for the pressure switch to become unsatisfied and restart the package.

Note, this type of control system has several advantages:

- 1) Provides Automatic start & stop control
- 2) Controls the number of starts per hour, which prolongs the life of the motor
- 3) Helps the package to achieve proper operating temperature which helps avoid the condensation build-up in the coolant.

The pressure switch cover can be removed by unscrewing the two screws holding the cover.

PRESSURE SWITCH ADJUSTMENT:

The compressor package will cut-in and cut-out at factory preset pressure settings. Adjust the pressure switch only if absolutely necessary. Adjustments are to be carried out only when the switch is mounted, under pressure and voltage-free.

OPERATING INSTRUCTIONS

⚠ WARNING

High voltage is present at the pressure switch contacts when the power supply is connected. Disconnect, lock and tag main power supply before making adjustments.

⚠ WARNING

Do not adjust the pressure switch to exceed the maximum discharge pressure of the unit.

NOTE

When replacing the pressure switch cover, ensure the selector knob on the cover and the lever on the switch are both in the "OFF" position.

NOTE

When the compressor is equipped with the optional dryer and filters, the pressure switch differential should be increased 10psi to account for the added pressure drop of the filters and dryer.

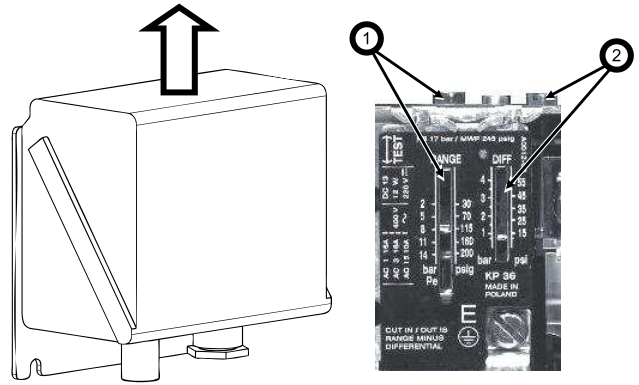

22505309 REV. A

⚠ CAUTION

Running unloaded with no air demand, will cause the unit to be shutoff by the pressure switch after the timer times out.

OPERATING INSTRUCTIONS

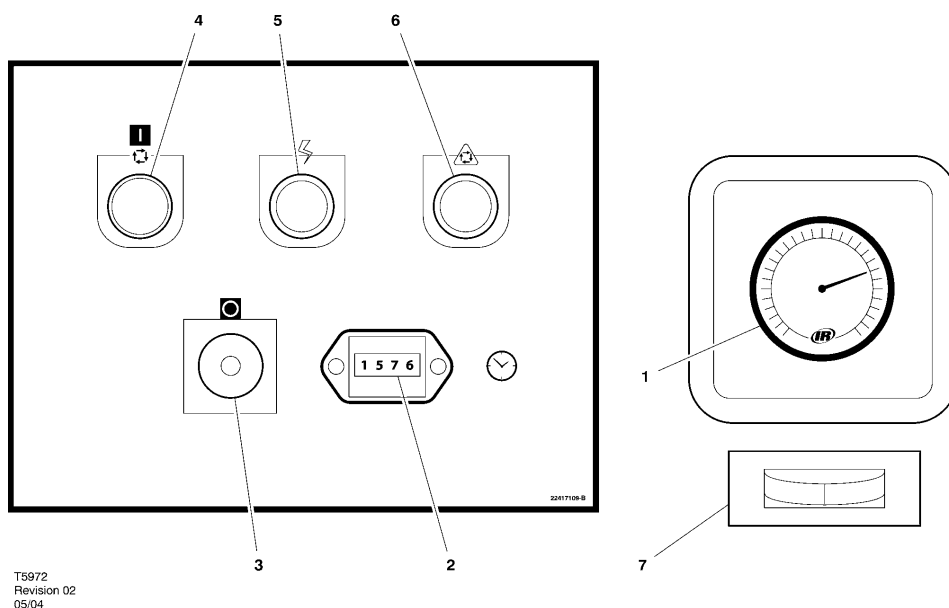

- 1) PRESSURE GAUGE -Indicates the system pressure.

WARNING

DO NOT operate the compressor at discharge pressures exceeding the maximum operating pressure.

- 2) HOURMETER - Records the total running time of the compressor.
- 3) STOP BUTTON / EMERGENCY STOP - When depressed will stop the compressor immediately. The 'Power on' indicator will remain illuminated. The STOP button must be released before the compressor can be restarted.
- 4) ON PUSH BUTTON SWITCH -When depressed will cause the unit to start and run in a loaded condition if there is a demand for air. If there is no demand, the machine will stop automatically.
- 5) POWER ON INDICATOR LIGHT (Green) - Indicates the presence of control voltage.
- 6) STOPPED/AUTO RESTART INDICATOR LIGHT (Amber) - Will illuminate when the machine has shut-down due to low air demand. The machine will restart and load automatically as soon as the demand for air returns.
- 7) DEW POINT INDICATOR (Dryer Option) - Green indicates good dew point. Red indicates dew point above 50°F (10°C) Blue indicates freezing.

PRIOR TO STARTING

- 1) Make visual check of the machine, ensure that all guards secure and that nothing is obstructing the proper ventilation of, or free access to the machine.
- 2) Check coolant level. Add if necessary.
- 3) Make sure air discharge valve is open.

- 4) Turn on electrical isolator or disconnect. The Power on (5) indicator will light, indicating that line and control voltages are available.
- 5) Check direction of rotation at initial start or following interruption in power supply.

WARNING

Make sure that all protective covers are in place. Cooling air flow exhaust may contain flying debris. Safety protection should be worn at all times to avoid injury.

STARTING

- 1) Press the START button. The compressor will start and then load automatically.

NORMAL/EMERGENCY STOPPING

- 1) Press STOP button (3) and the compressor will stop immediately.
- 2) Turn off electrical isolator or disconnect.

CAUTION

After shutdown never allow unit to stand idle with pressure in receiver/separator system.

MAINTENANCE

MAINTENANCE SCHEDULE

UP SERIES MAINTENANCE SCHEDULE

PERIOD	MAINTENANCE
Each 24 hours operation	Check the coolant level and replenish if necessary.
Visual check of machine for any leaks, dust build up or unusual noise or vibration	Report immediately, contact Ingersoll Rand authorized distributor for assistance if in doubt.
When compressor is receiver mounted	Drain air receiver of condensate, or check that automatic drain is operating.
Visual check condition of package pre-filter	Blow clean if needed.
First 150 hours	Change the coolant filter.
Each month or 100 hours	Remove and clean package pre-filter, replace if needed Check the cooler(s) for build up of foreign matter.Clean if necessary by blowing out with air or by pressure washing.
Every 1000 hours	Analyze food grade lubricant (Ultra FG)
Each year or 2000 hours	Check the operation of the high temperature protection switch (109°C).
	Replace elements in IRGP and IRHE filters.
	Change the coolant filter.
	Check scavenge screen for blockage, clean if required.
	Change the separator element.
	Change the Air Filter element.
	Take coolant sample for fluid analysis (Ultra/Ultra EL).
	Change the package pre-filter.
	Check Drive Belts.
	Motors with grease fittings-grease per motor data TAG
Every 6000 Hours	Replace food grade lubricant(Ultra FG).
	Check and replace all items included within 2000 hour service.
1 year external and 6 years internal pressure vessel inspection. Frequency may be otherwise defined by local or national legislation.	Separator vessel and air receiver when fitted
	Fully inspect all external surfaces, and fittings. Report any excessive corrosion, mechanical or impact damage, leakage or other deterioration.
Every two years or 8000 hours	Change drive belts.
	Replace Premium Coolant (Ultra) at whichever interval occurs first.
	Check and replace all items included within 2000 hour service.
	Fit the following reconditioning parts as appropriate: Solenoid valves Inlet valve kit Minimum Pressure valve kit Thermostatic Valve Kit

16000 hours or every 3 years	Replace Extended-life Premium Coolant (Ultra EL)
Every 4 years or 16000 hours	Replace all hoses.
	Strip, clean and re-grease motor bearings on motors with grease fittings
	Fit replacement electrical contactor tips.
	Motors without grease fittings - replace sealed bearings

ROUTINE MAINTENANCE

This section refers to the various components which require periodic maintenance and replacement.

It should be noted that the intervals between service requirement may be significantly reduced as a consequence of poor operating environment. This would include effects of atmospheric contamination and extremes of temperature.

The SERVICE/MAINTENANCE CHART indicates the various components' descriptions and the intervals when maintenance has to take place. Oil capacities, etc., can be found in the PRODUCT INFORMATION SHEET.

Compressed air can be dangerous if incorrectly handled. Before doing any work on the unit, ensure that all pressure is vented from the system and that the machine cannot be started accidentally.

⚠ CAUTION

Before beginning any work on the compressor, open, lock and tag the main electrical disconnect and close the isolation valve on the compressor discharge. Vent pressure from the unit by slowly unscrewing the coolant fill cap one turn. Unscrewing the fill cap opens a vent hole, drilled in the cap, allowing pressure to release to atmosphere. Do not remove the fill cap until all pressure has vented from the unit. Also vent piping by slightly opening the drain valve. When opening the drain valve or the coolant fill cap, stand clear of the valve discharge and wear appropriate eye protection.

Ensure that maintenance personnel are properly trained, competent and have read the Maintenance Manuals.

Prior to attempting any maintenance work, ensure that:-

- all air pressure is fully discharged and isolated from the system. If the automatic blowdown valve is used for this purpose, then allow enough time for it to complete the operation.
- the machine cannot be started accidentally or otherwise.
- all residual electrical power sources (mains and battery) are isolated.

MAINTENANCE

Prior to opening or removing panels or covers to work inside a machine, ensure that:-

- anyone entering the machine is aware of the reduced level of protection and the additional hazards, including hot surfaces and intermittently moving parts.
- the machine cannot be started accidentally or otherwise.

Prior to attempting any maintenance work on a running machine, ensure that:-

⚠ DANGER

Only properly trained and competent persons should undertake any maintenance tasks with the compressor running or with electrical power connected.

- the work carried out is limited to only those tasks which require the machine to run.
- the work carried out with safety protection devices disabled or removed is limited to only those tasks which require the machine to be running with safety protection devices disabled or removed.
- all hazards present are known (e.g. pressurised components, electrically live components, removed panels, covers and guards, extreme temperatures, inflow and outflow of air, intermittently moving parts, safety valve discharge etc.).
- appropriate personal protective equipment is worn.
- loose clothing, jewellery, long hair etc. is made safe.
- warning signs indicating that Maintenance Work in Progress are posted in a position that can be clearly seen.

Upon completion of maintenance tasks and prior to returning the machine into service, ensure that:-

- the machine is suitably tested.
- all guards and safety protection devices are refitted and correctly working.
- all panels are replaced, canopy and doors closed.
- hazardous materials are effectively contained and disposed of in a manner compliant with local or National environmental protection codes.

⚠ WARNING

Do not under any circumstances open any drain valve or remove components from the compressor without first ensuring that the compressor is FULLY SHUT-DOWN, power isolated and all air pressure relieved from the system.

TOP UP COOLANT PROCEDURE

- 1) Slowly remove fill cap.
- 2) Pour coolant into spout until spout almost overflows.
- 3) Replace and tighten oil fill cap.
- 4) Start unit for about 10 seconds (until coolant drains out the bottom of the sight glass).
- 5) Slowly remove fill cap.
- 6) Re-fill into spout until spout almost overflows.

7) Replace and tighten oil fill cap.

8) Run unit.

NOTE

Coolant level is correct when a unit is showing coolant in bottom half of sight glass when up to operating temperature (ten minutes running loaded).

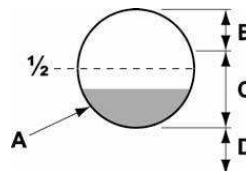

A. Correct at operating temperature

B. Too much

C. OK

D. Too little

Repeat this procedure to get coolant to proper level when up to operating temperature.

When the unit is shut down, coolant will usually fill up sight glass. Do not adjust level based on level at shutdown. Proper level is always set for a running unit at operating temperature.

⚠ CAUTION

Ensure that Ingersoll premium coolant is used. Failure to do so will void manufacturer warranty.

COOLANT CHANGE PROCEDURE

It is better to drain the coolant immediately after the compressor has been operating as the liquid will drain more easily and any contaminant will still be in suspension.

- 1) Stop the machine, electrically isolate and vent all trapped pressure.
- 2) Place a suitable container close to the drain valve.
- 3) Slowly remove fill cap.
- 4) Remove plug from drain valve.
- 5) Open the drain valve and drain coolant into container.
- 6) Close the drain valve.
- 7) Replace plug in drain valve.
- 8) Refill the machine following the "top up coolant" procedure above. After initial fill, to purge any airlocks, the machine should be run for a few minutes cycling between load and no load, before checking that the level is correct.
- 9) Replace and tighten oil fill cap.

COOLANT FILTER CHANGE PROCEDURE

- 1) Stop the machine, electrically isolate and vent all trapped pressure.
- 2) Loosen filter with the correct tool.
- 3) Remove the filter from the housing.
- 4) Place the old filter in a sealed bag and dispose of in a safe way.

MAINTENANCE

- 5) Clean the mating face of the housing taking care to avoid any particles entering the machine.
- 6) Remove the new **Ingersoll Rand** replacement filter from its protective package.
- 7) Apply a small amount of lubricant to the filter seal.
- 8) Screw the new filter down until the seal makes contact with the housing, then hand tighten a further half turn.
- 9) Start the compressor and check for leaks.

⚠ CAUTION

This unit is not designed or intended to operate when contaminated with silicone. Lubricants, greases or other items containing silicone should not be used on this unit.

COOLER CLEANING PROCEDURE

- 1) Stop the machine, electrically isolate and vent all trapped pressure.
- 2) Remove the top cover to obtain access to the cooler.
- 3) Clean the cooler.
- 4) Rebuild in reverse order.

BELT CHECKING AND ADJUSTMENT PROCEDURE

Check belt tension occasionally, especially if looseness is suspected. A quick check to determine if adjustment is proper may be made by observing the slack side of the belt for a slight bow when the unit is in operation.

If a slight bow is evident, the belt is usually adjusted satisfactorily.

A belt tension measurement device can be used to determine the tension of the belt.

Belt tensioning can be achieved by loosening the aircend anchor screws, a belt tensioning bolt is provided to aid in moving the aircend.

Follow the procedures outlined below to correctly set and measure belt tension.

- 1) Lay a straight edge across the top outer surface of the belt drive from pulley to sheave.

At the center of the span, perpendicular to the belt, apply pressure to the outer surface of the belt with a tension gauge. Force the belt to the deflection indicated in the table below, and compare the reading on the tension gauge to the figures shown. -**Belt tension**

AIR FILTER ELEMENT CHANGE PROCEDURE

- 1) Stop the machine, electrically isolate and vent all trapped pressure.
- 2) Unscrew the retaining cap and withdraw the old element.
- 3) Fit the new element.
- 4) Replace the retaining cap.

SEPARATOR ELEMENT CHANGE PROCEDURE

- 1) Stop the machine, electrically isolate and vent all trapped pressure.
- 2) Loosen separator element with the correct tool.
- 3) Remove the element from the housing; place it in a sealed bag and dispose of it safely.
- 4) Clean the mating face of the housing.
- 5) Remove the new **Ingersoll Rand** replacement element from its protective package.
- 6) Apply a small amount of lubricant to the element seal.
- 7) Screw the new element down until the seal makes contact with the housing, then hand tighten a further 1/4 turn.
- 8) Start the compressor and check for leaks.

BELT TENSION								
	5hp/4kw *		7.5hp/5.5kw *		10hp/7.5kw *		15hp/11kw **	
	New	Used	New	Used	New	Used	New	Used
60hz								
125 psig	75 Lb (34 Kg)	62 Lb (28 Kg)	110 Lb (50 Kg)	90 Lb (41Kg)	110 Lb (50 Kg)	90 Lb (41Kg)	140 Lb (64 Kg)	120 Lb (54 Kg)
150 psig	75 Lb (34 Kg)	62 Lb (28 Kg)	90 Lb (41Kg)	75 Lb (34 Kg)	110 Lb (50 Kg)	90 Lb (41Kg)	140 Lb (64 Kg)	120 Lb (54 Kg)
210 psig	75 Lb (34 Kg)	62 Lb (28 Kg)	90 Lb (41Kg)	75 Lb (34 Kg)	110 Lb (50 Kg)	90 Lb (41Kg)	150 Lb (68 Kg)	125 Lb (57 Kg)
50hz								
8 bar	85 Lb (39 Kg)	70 Lb (32 Kg)	85 Lb (39 Kg)	70 Lb (32 Kg)	110 Lb (50 Kg)	90 Lb (41Kg)	140 Lb (64 Kg)	120 Lb (54 Kg)
10 bar	90 Lb (41Kg)	75 Lb (34 Kg)	85 Lb (39 Kg)	70 Lb (32 Kg)	120 Lb (54 Kg)	100 Lb (45 Kg)	140 Lb (64 Kg)	120 Lb (54 Kg)
14.5 bar	90 Lb (41Kg)	75 Lb (34 Kg)	100 Lb (45 Kg)	80 Lb (36 Kg)	120 Lb (54 Kg)	100 Lb (45 Kg)	150 Lb (68 Kg)	125 Lb (57 Kg)
* "Kriket I" gauge or equal								
** "Kriket II" gauge or equal								

MAINTENANCE

Ensure the pulley and sheave are properly aligned and the motor anchor screws are adequately retightened prior to restarting the compressor.

ELECTRIC DRAIN VALVE

PRODUCT DESCRIPTION

The Electric Drain Valve removes condensed water and oil from the moisture separator. Additional drains may be installed throughout your compressed air system, including aftercoolers, filters, drip legs and dryers.

The Electric Drain Valve operates on a timer which can be set to automatically drain the air receiver tank at operator-determined intervals.

Key features include:

- 100% continuous duty
- NEMA 4 enclosure
- Adjustable time on (0.5 – 10 seconds)
- Adjustable time off (0.5 – 45 minutes)
- Stainless steel operator
- LED to indicate electrical power is on
- LED to indicate valve is open
- Manual override

OPERATION

1. Open the strainer ball valve.

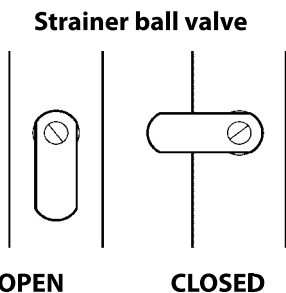

2. Set the “time off” and “time on” knobs. See **TIMER SETTINGS** (below) for an explanation of the settings.

3. During compressor operation, check for air leaks.

TIMER SETTINGS

The “time off” setting determines the interval between cycles from 30 seconds to 45 minutes. The “time on” setting determines the actual time the compressor drains condensate. The timer’s cycle rate and drain opening time should be adjusted to open just long enough to discharge the condensate. The timer is properly set when it opens and discharges condensate and then vents air for approximately one second before closing. Adjustments may be made depending on many factors, including humidity and duty cycle.

TROUBLESHOOTING

TROUBLE	CAUSE	ACTION
Valve will not close.	1. Debris in solenoid valve prevents diaphragm from seating.	1. Remove solenoid valve, disassemble, clean and reassemble.
	2. Short in electrical component.	2. Check and replace power cord or timer as needed.
Timer will not activate	1. No electrical supply.	1. Apply power.
	2. Timer malfunction.	2. Replace timer.
	3. Clogged port.	3. Clean valve.
	4. Solenoid valve malfunction.	4. Replace solenoid valve.
	5. Clogged strainer.	5. Clean strainer.

MAINTENANCE

Periodically clean the screen inside the valve to keep the drain functioning at maximum capacity. To do this, perform the following steps:

- 1) lose the strainer ball valve completely to isolate it from the air receiver tank.
- 2) Press the **TEST** button on the timer to vent the pressure remaining in the valve. Repeat until all pressure is removed.

⚠ CAUTION

High pressure air can cause injury from flying debris. Ensure the strainer ball valve is completely closed and pressure is released from the valve prior to cleaning.

- 4) Remove the plug from the strainer with a suitable wrench. If you hear air escaping from the cleaning port, **STOP IMMEDIATELY** and repeat steps 1 and 2.
- 5) Remove the stainless steel filter screen and clean it. Remove any debris that may be in the strainer body before replacing the filter screen.
- 6) Replace plug and tighten with wrench.
- 7) When putting the Electric Drain Valve back into service, press the **TEST** button to confirm proper function.

Before accessing live electrical parts, disconnect the power supply to the dryer using disconnect switch or disconnect the cable connections.

MAINTENANCE

PREVENTIVE MAINTENANCE

For optimum performance from your dryer, follow the periodic maintenance schedule described below.

WEEKLY	<p>CONDENSATE DRAINS</p> <p>Verify that the condensate drains are operating correctly.</p>
EVERY 4 MONTHS	<p>CONDENSER</p> <p>Remove any dust from the con-denser fins.</p>
	<p>COMPRESSOR</p> <p>Make sure compressor power consumption complies with data plate specifications.</p>
YEARLY	<p>CONDENSATE DRAINS</p> <p>Completely disassemble the drains and clean all their components.</p>
	<p>AIR FILTER</p> <p>Replace air filter element.</p>

MOISTURE SEPARATOR MAINTENANCE

The moisture separator will operate indefinitely under normal working conditions, however at some time it may be necessary to replace the seals should the housing leak.

- 1) Isolate the housing from the air supply.
- 2) Fully depressurize in drain bowl as appropriate.
- 3) Unscrew bowl and remove. If pressure has not been completely released from the housing, air will escape from the warning hole giving an audible alarm. Screw back bowl and repeat instruction 2 before attempting again. Should resistance to unscrewing be experienced, provision is made for a 'C' spanner to fit onto the ribs of the bowl.
- 4) Check condition of bowl seal and replace if necessary. Clean screw threads.
- 5) Refit bowl with 'O' ring seal.
- 6) Repressurize and check for leaks. If leaks occur they will most probably be from the bowl 'O' ring. Depressurize housing and remove 'O' ring as stated above and inspect and clean. Ensure that mating surfaces are clean and then refit 'O' ring and repressurize.

AIR FILTER MAINTENANCE

In order to ensure optimum compressed air quality the filter element should be replaced as follows. (Used filter elements must be disposed of in accordance with local regulations.)

Use only genuine **Ingersoll Rand** replacement elements.

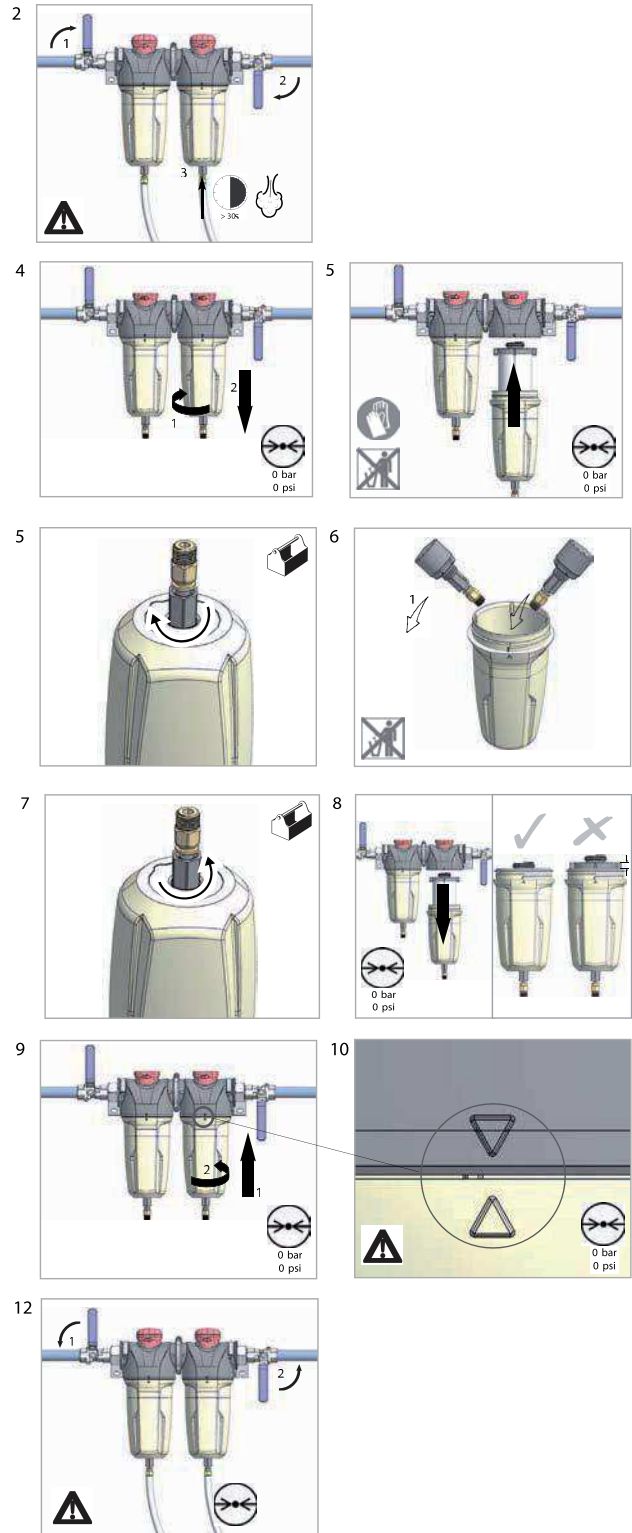

MAINTENANCE

DISASSEMBLING THE UNIT

The unit has been designed and constructed to guarantee continuous operation.

The long service life of some components such as the fan and compressor depends on good maintenance.

The unit must only be disassembled by a refrigerant specialist.

Refrigerant liquid, refrigeration components and lubricating oil inside the refrigeration circuit must be recovered in compliance with current norms in the country where the machine is installed.

RECYCLING DISASSEMBLY	
Frame and panels	Steel / epoxy resin polyester
Heat exchanger (cooler)	Stainless steel
Pipes	Copper
Insulation	Gum synthetic
Compressor	Steel / copper / aluminium / oil
Condenser	Aluminium
Refrigerant	R134a
Valve	Steel

REFRIGERANT LEAKS IN THE REFRIGERATION CIRCUIT

The unit is despatched in perfect working order, already charged.

Refrigerant leaks may be identified by tripping of the refrigeration overload protector.

IF A LEAK IS DETECTED IN THE REFRIGERANT CIRCUIT, SEEK TECHNICAL ASSISTANCE.

REFRIGERANT CHARGING

This operation must only be performed by a refrigerant specialist.

WHEN REPAIRING THE REFRIGERANT CIRCUIT, COLLECT ALL THE REFRIGERANT IN A CONTAINER AND DISPOSE OF IT IN THE APPROPRIATE MANNER.

CHARACTERISTICS OF REFRIGERANT R134A

In normal temperature and pressure conditions the above refrigerant is a colorless, class A1/A1 gas with TVL value of 1000ppm (ASHRAE classification).

If a refrigerant leak occurs, thoroughly air the room before commencing work.

TROUBLESHOOTING

TROUBLE	CAUSE	ACTION
Solenoid condensate valve will not close	1. Debris in solenoid valve prevents diaphragm from seating.	1. Remove solenoid valve, disassemble, clean and reassemble.
	2. Short in electrical components.	2. Check and replace power cord or timer as needed.
Drain timer will not operate	1. No electrical supply.	1. Apply power.
	2. Timer malfunction.	2. Replace timer.
	3. Clogged port.	3. Clean valve.
	4. Solenoid valve malfunction.	4. Replace solenoid valve.
	5. Clogged strainer.	5. Clean strainer.

MAINTENANCE

Periodically clean the screen inside the valve to keep the drain functioning at maximum capacity. To do this, perform the following steps:

- 1) Close the strainer ball valve completely to isolate it from the air receiver tank.
- 2) Press the TEST button on the timer to vent the pressure remaining in the valve. Repeat until all pressure is removed.

CAUTION

High pressure air can cause injury from flying debris. Ensure the strainer ball valve is completely closed and pressure is released from the valve prior to cleaning.

- 3) Remove the plug from the strainer with a suitable wrench. If you hear air escaping from the cleaning port, STOP IMMEDIATELY and repeat steps 1 and 2.
- 4) Remove the stainless steel filter screen and clean it. Remove any debris that may be in the strainer body before replacing the filter screen.
- 5) Replace plug and tighten with wrench.
- 6) When putting the Electric Drain Valve back into service, press the TEST button to confirm proper function.

TROUBLE SHOOTING

PROBLEM	CAUSE	REMEDY
Compressor fails to start	Mains power or Control voltage not available.	§ Check incoming power supply.
		§ Check the control circuit fuse.
		§ Check the transformer secondary windings for the controlvoltage.
	Defective Star / Delta timer.	§ Change Star / Delta timer.
Machine shuts down periodically	High airend temperature.	Top up coolant.
	Motor overload.	§ Set overload to correct value and switch to manual reset.
	Line voltage variation.	§ Ensure voltage does not drop below 10% on start up and 6% running.
High current draw	Compressor operating aboverated pressure.	Set pressure to correct rating for machine.
	Separator cartridge contaminated.	Change air filter, and separator element.
	Low voltage.	§ Ensure voltage does not drop below 10% on start up and 6% running.
	Unbalanced voltage.	Correct incoming supply voltage.
	Damaged airend.	† Change Airend.
Low current draw	Air filter contaminated.	Change air filter.
	Compressor operating unloaded.	Set pressure to correct rating for machine.
	High voltage.	Reduce site voltage to correct operating voltage.
	Defectiveinlet valve.	† Fit inlet valve service kit.
High discharge pressure	Defective or incorrect pressure switch setting.	Replace or set pressure to correct rating for machine.
	Blowdown valve defective.	† Fit blowdown solenoid service kit.
	Inlet valvemalfunction.	† Fit inlet valve service kit.
Low system air pressure	Separator cartridge contaminated.	Fit new Separator element.
	Incorrect pressure transducer setting	Set pressure to correct rating for machine.
	Minimum pressure valvemalfunction.	† Fit Minimum pressure valve service kit.
	Blowdown valve defective.	† Fit blowdown solenoid service kit.
	Drivebeltslipping.	Fit new belt.
	Air system leaks.	† Fixleaks.
	Inlet valvemalfunction.	† Fit inlet valve service kit.
	System demand exceeds compressor delivery.	Reduce demand or install additional compressor.
Compressed air filters contaminated.	Replace air filter elements.	
High dewpoint	Refrigeration compressor not supplied power.	Check incoming power supply.
		Check the dryer protection fuse.
		Check auxiliary contact on main motor contactor.
	Condensate system malfunction.	Check operation of drain valve.
		Check operation of condensate check valves.
	Condenser dirty.	Clean condenser and replace panelfilter element.
Ice formation in dryer	Low evaporator pressure.	Check hot gas valve setting.

TROUBLE SHOOTING

PROBLEM	CAUSE	REMEDY
Compressor trips due to over temperature	Compressor operating above rated pressure.	Set pressure to correct rating for machine.
	Package pre-filter blocked.	Clean / replace package pre-filter.
	Cooler blocked.	Clean cooler.
	Missing or incorrectly fitted enclosure panels	Ensure that all enclosure panels are correctly fitted.
	Low coolant level.	Top up coolant and check for leaks.
	High ambient temperature.	Re-site compressor.
	Restricted cooling air flow.	Ensure correct air flow to compressor.
Excessive coolant consumption	Separator element leak.	Fit new Separator element.
	Blocked separator element drain.	† Remove fittings and clean.
	Compressor operating below rated pressure.	Set pressure to correct rating for machine.
	Coolant system leak.	† Fixleaks.
Excessive noise level	Air system leaks.	† Fixleaks.
	Airend defective.	† Change Airend.
	Belts Slipping.	Replace belt and tensioner.
	Motor defective.	† Replace motor.
	Loose components.	† Retighten loose items.
Shaft seal leaking	Defective shaft seal.	† Fit Airend shaft seal kit.
Pressure relief valve opens	Defective switch or incorrect pressure switch setting.	Replace or set pressure to correct rating for machine.
	Minimum pressure valvemalfunction.	† Fit Minimum pressure valve service kit.
	Blowdown valve defective.	† Fit blowdown solenoid service kit.
	Inlet valvemalfunction.	† Fit inlet valve service kit.
	Pressure relief valve defective.	Check the setting of the pressure relief valve and the rated pressure.
Black residue on belt guard/ cooler box	Drivebeltslipping.	Replace belt and tensioner.
	Pulleys misaligned.	Re-align pulleys.
	Worn pulleys.	† Replace pulleys and belt.
Safety valve blows when compressor goes on load	Minimum pressure valve stuck closed.	Strip minimum pressure valve, examine and repair if necessary.
	Safety valve faulty	Check the setting of the safety valve and the rated pressure.

NOTE

§ **Must be carried out by a competent electrician.**

† **This work is recommended to be carried out only by an Ingersoll Rand authorized service technician.**

CAUTION

LOW DEMAND APPLICATIONS

During periods of low demand, the compressor may not reach its normal operating temperature. Sustained operation at low demand can result in the build up of condensate in the coolant. If this situation occurs, the lubricating characteristics of the coolant can be impaired which may lead to damage of the compressor.

THE COMPRESSOR SHOULD BE ALLOWED AMPLE LOADED RUNNING TIME OF AT LEAST 10 MINUTES PER HOUR DURING NORMAL DAILY USE.



A series of horizontal lines spanning the width of the page, providing a template for writing.



A series of horizontal lines spanning the width of the page, providing a template for writing.



A series of horizontal lines forming a ruled page for writing. The lines are evenly spaced and extend across the width of the page.

