



22207666

Revision F

April 2024

## Reciprocating Air Compressors Models TS4 & 2200

---

### Owner's Manual with Parts Lists

- EN** Owner's Manual with Parts Lists
- ES** Manual del propietario con la lista de piezas
- FR** Manuel du propriétaire avec liste des pièces



**Save These Instructions**



---

**CONTENTS**

---

<b>SAFETY</b> .....	<b>3</b>	<b>COMPRESSOR LUBRICATION</b> .....	<b>9</b>
<b>GENERAL SAFETY PRECAUTIONS</b> .....	<b>3</b>	SYNTHETIC COMPRESSOR LUBRICANT .....	9
<b>RECEIPT &amp; INSPECTION</b> .....	<b>4</b>	ALTERNATE LUBRICANTS .....	9
<b>INSTALLATION</b> .....	<b>5</b>	FILLING PROCEDURES:.....	9
SELECTING A LOCATION .....	5	<b>OPERATION</b> .....	<b>10</b>
AMBIENT TEMPERATURE CONSIDERATIONS .....	5	<b>START-UP</b> .....	<b>10</b>
HUMID AREAS .....	5	<b>OIL CONSUMPTION CHECK</b> .....	<b>10</b>
NOISE CONSIDERATIONS .....	5	<b>MAINTENANCE</b> .....	<b>11</b>
MOUNTING .....	5	<b>FILTER INSPECTION &amp; CLEANING</b> .....	<b>12</b>
INSTALLING REMOTE AIR INLET PIPING .....	6	OIL CHANGE .....	12
<b>TYPICAL REMOTE AIR INLET PIPING</b> .....	<b>6</b>	BELT ADJUSTMENT .....	12
<b>INSTALLING DISCHARGE PIPING</b> .....	<b>7</b>	TANK INSPECTION.....	12
<b>GENERAL REQUIREMENTS</b> .....	<b>7</b>	<b>TROUBLESHOOTING</b> .....	<b>13</b>
<b>CONDENSATE DISCHARGE PIPING</b> .....	<b>7</b>	<b>DIAGRAMS &amp; TABLES</b> .....	<b>15</b>
<b>ELECTRICAL CONNECTIONS</b> .....	<b>7</b>	<b>ELECTRICAL WIRING DIAGRAMS</b> .....	<b>16</b>
GENERAL .....	7	SINGLE PHASE WIRING.....	16
WIRE SIZE .....	7		
FUSES .....	7		
GROUNDING INSTRUCTIONS.....	8		
PRESSURE SWITCH ELECTRICAL CONNECTIONS.....	8		

## SAFETY

**⚠ DANGER**

Indicates an imminently hazardous situation which, if not avoided, will result in death or serious injury.

**⚠ WARNING**

Indicates a potentially hazardous situation which, if not avoided, could result in death or serious injury.

**⚠ CAUTION**

Indicates a potentially hazardous situation which, if not avoided, may result in minor or moderate injury or property damage.

**NOTICE**

Indicates information or a company policy that relates directly or indirectly to the safety of personnel or protection of property.

**■ GENERAL SAFETY PRECAUTIONS****⚠ DANGER**

**Intake air can contain carbon monoxide or other contaminants. Will cause serious injury or death. Ingersoll Rand air compressors are not designed, intended or approved for breathing air. Compressed air should not be used for breathing air applications unless treated in accordance with all applicable codes and regulations.**

**⚠ WARNING**

**A hazardous voltage can cause serious injury or death. Disconnect power and bleed pressure from the tank before servicing. Lockout/tagout machine. Compressor must be connected to properly grounded circuit. See grounding instructions in manual. Do not operate compressor in wet conditions. Store indoors.**

**Moving parts. Can cause serious injury. Do not operate with guards removed. Machine may start automatically. Disconnect power before servicing. Lockout/tagout machine.**

**Hot surfaces. Can cause serious injury. Do not touch. Allow to cool before servicing. Do not touch hot compressor or tubing.**

**High pressure air. Bypassing, modifying or removing safety/relief valves can cause serious injury or death. Do not bypass, modify or remove safety/relief valves. Do not direct air stream at body. Rusted tanks can cause explosion and severe injury or death. Drain tank daily or after each use. Drain valve located at bottom of tank.**

**⚠ CAUTION**

**A caution risk of bursting. Use only suitable air handling parts acceptable for pressure of not less than the maximum allowable working pressure of the machine.**

---

## RECEIPT & INSPECTION

---

Ensure adequate lifting equipment is available for unloading and moving the compressor to the installation site.

### NOTICE

**Lifting equipment must be properly rated for the weight of the unit.**

### CAUTION

**Lift the compressor by the shipping skid only. Do not use the motor lifting eye to lift the entire compressor. The motor lifting eye is for removing the motor from the compressor only.**

### CAUTION

**Do not work on or walk under the compressor while it is suspended.**

Use suitable lifting equipment (i.e. forklift) to lift and transport the compressor to the installation site. Ensure the lifting equipment, straps, etc. are capable of supporting the weight of the unit.

### *Lifting Equipment and Straps*



Before signing the delivery receipt, inspect for damage and missing parts. If damage or missing parts are apparent, make the appropriate notation on the delivery receipt, then sign the receipt. Immediately contact the carrier for an inspection.

All material must be held in the receiving location for the carrier's inspection.

Delivery receipts that have been signed without a notation of damage or missing parts are considered to be delivered "clear." Subsequent claims are then considered to be concealed damage claims. Settle damage claims directly with the transportation company.

If you discover damage after receiving the compressor (concealed damage), the carrier must be notified within 15 days of receipt and an inspection must be requested by telephone with confirmation in writing. On concealed damage claims, the burden of establishing that the compressor was damaged in transit reverts back to the claimant.

Read the unit nameplate to verify it is the model ordered, and read the motor nameplate to verify it is compatible with your electrical conditions. Make sure electrical enclosures and components are appropriate for the installation environment.

## INSTALLATION

### ■ SELECTING A LOCATION

For most electric motor units, select a relatively clean and dry well-lighted indoor area with plenty of space for proper ventilation, cooling air flow and accessibility. Provide 1,000 cubic feet of fresh air per 5 horsepower. Locate the unit at least 15 inches (38 cm) from walls, and make sure the main power supply is clearly identified and accessible.

Unless the electrical components of the unit are specially protected for outdoor use, do not install an electric motor unit outdoors or in an area that will expose the electrical components to rain, snow or sources of appreciable moisture.



#### WARNING

The electric drain valve incorporates arcing or sparking parts, such as snap switches, receptacles and the like that tend to produce arcs or sparks and, therefore, when located in a garage, the compressor should be in a room or enclosure provided for the purpose, or the electric drain valve should be 18 inches (457 mm) or more above the floor.

### ■ AMBIENT TEMPERATURE CONSIDERATIONS

Ideal operating temperatures are between 32°F and 100°F (0°C and 37.8°C). If temperatures consistently drop below 32°F (0°C), install the compressor in a heated area. If this is not possible, you must protect safety/relief valves and drain valves from freezing. If temperatures are consistently below 40°F (4.4°C), consider installing an external crankcase heater kit, especially if the compressor has difficulty starting.



#### CAUTION

Never operate the compressor in temperatures below 20°F (6.6°C) or above 104°F (40°C).

### ■ HUMID AREAS

In frequently humid areas, moisture may form in the pump and produce sludge in the lubricant, causing running parts to wear out prematurely. Excessive moisture is especially likely to occur if the unit is located in an unheated area that is subject to large temperature changes.

Two signs of excessive humidity are external condensation on the pump when it cools down and a "milky" appearance in petroleum lubricant.

You may be able to prevent moisture from forming in the pump by increasing ventilation, operating for longer intervals or installing an external crankcase heater kit.

### ■ NOISE CONSIDERATIONS

Consult local officials for information regarding acceptable noise levels in your area. To reduce excessive noise, use vibration isolator pads or intake silencers, relocate the unit or construct total enclosures or baffle walls.

### ■ MOUNTING



#### WARNING

Remove the compressor from the skid before mounting. Refer to the RECEIPT & INSPECTION section of this manual for information on lifting and handling the compressor.

#### NOTICE

- Secure the compressor to a solid, flat and level mounting surface.
- Do not install the compressor on I-beams, open-grid flooring systems, or non-solid surfaces.
- If vibration isolation mounts/pads or mounting hardware are included with your compressor, they must be properly installed.
- Follow guidelines within this manual where kits are not provided.
- Failure to install per instructions may result in mechanical failure to the compressor and cancellation of warranty coverage.
- Mounting kits may be ordered through your Ingersoll Rand dealer if not included with the compressor. Consult your local Ingersoll Rand dealer for more information.
- Local codes may mandate specific mounting requirements.

#### NOTICE

You must utilize your own hardware unless the compressor is provided with a mounting hardware kit.

To mount the compressor to a concrete surface, use the following procedure:

1. Mark the location of the mounting holes.
2. Drill holes to the proper depth based on the concrete stud. Using a concrete stud sized per the following table and follow the concrete stud instructions to determine proper drill bit size (Note: It may be helpful to use a piece of tape on the drill bit to mark the proper depth).

Tank Size (Gal.)	Stud Size (In.)
≤ 120	1/2
≥ 240	5/8

3. Add a backing plate as depicted in Illustration, while maintaining a level mounting surface.
4. Position the compressor feet holes over the studs and slowly lower the compressor feet onto the studs.
5. Install the first standard nut and torque each in a criss-cross pattern to 10 ft.lb\*. After all mounting nuts are installed, check for receiver stress by loosening each nut individually to check for upward movement of the foot. Upward movement indicates the requirement for an appropriately sized metal shim to fill in the open elevation under the foot.
6. After all required shims have been inserted, re-tighten the nuts to 10 ft.lb\*.
7. Add a backup nut to keep the primary nut from backing off. Backup nut may be a locknut or a second standard nut. Ensure to not tighten the primary nut.

Do not secure uneven feet tightly, as this will cause excessive stress on the receiver tank.

\* For gas or diesel engine compressors, use the torque specification indicated in the mounting hardware kit installation instructions.

**Installation for 2200L5 - 60 Gallon Vertical  
(Hardware Not Provided)**

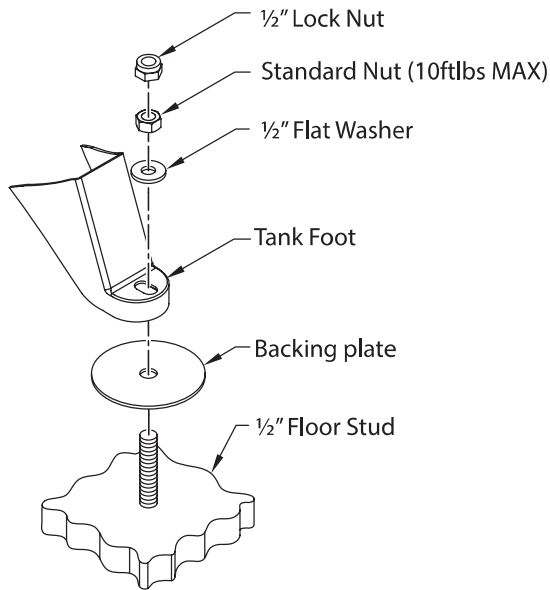

**Installation for TS4N5 - 80 Gallon Vertical  
(Hardware Provided)**

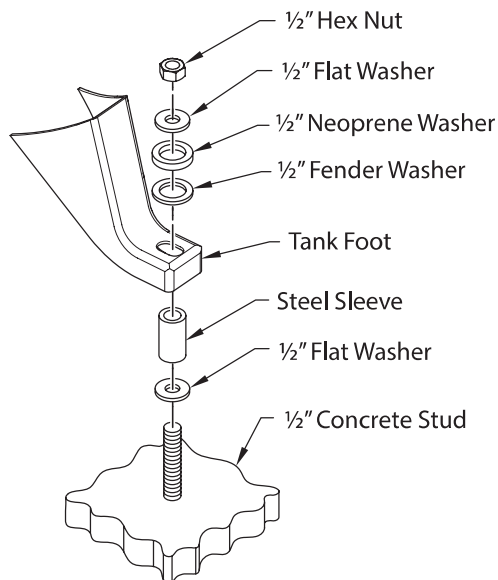

**INSTALLING REMOTE AIR INLET PIPING**

**CAUTION**

**Do not operate the unit without air inlet filtration.**

If the air around the unit is relatively free of dirt, install the air inlet filter at the inlet connection at the pump. If the air is dirty, pipe the filter to a source of clean air. Use PVC plastic tubes for remote inlet piping. Do not use black pipe or galvanized pipe, as these promote sweating and rust. Consider installing an in-line type filter for ease of cleaning and replacement. Make the line as short and direct as possible and as large, or larger, than the diameter of the inlet connection on the pump. Do not install piping with a diameter lower than that of the pump intake.

Increase the pipe diameter one size for every 10 feet (3 m) of length or every 90° bend. Make sure the piping is adequately braced.

If you pipe the filter outdoors, cover it with a hood to prevent the entrance of rain or snow.

Heavy duty filter elements and filtration equipment are available for fine airborne dust, such as cement and rock dust.

**TYPICAL REMOTE AIR INLET PIPING**

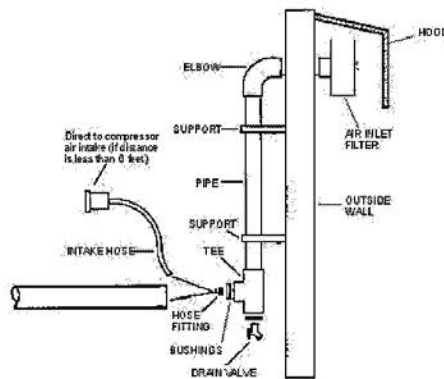

## ■ INSTALLING DISCHARGE PIPING

### ⚠ WARNING

**Do not use plastic pipe, soldered copper fittings, rubber hose, or lead-tin soldered joints anywhere in the compressed air system.**

### ⚠ CAUTION

**If you will be using synthetic compressor lubricant, all downstream piping material and system components must be compatible. Refer to the following material compatibility list. If there are incompatible materials present in your system, or if there are materials not included in the list, contact Ingersoll Rand for recommendations.**

#### SYNTHETIC COMPRESSOR LUBRICANT MATERIAL COMPATIBILITY LIST

##### SUITABLE :

FKM (Fluoroclastomer), PTFE, Epoxy (Glass Filled), Oil Resistant Alkyd, Fluorosilicone, Fluorocarbon, Polysulfide, 2-Component Urethane, Nylon, POM (Polyoxymethylene/Polyacetal), High Nitrile Rubber (Buna N. NBR more than 36% Acrylonitrile), Polyurethane, Polyethylene, Epichlorohydrin, Polyacrylate, Melamine, Polypropylene, Baked Phenolics, Epoxy, Modified Alkyds (® indicates trademark of DuPont Corporation).

##### NOT RECOMMENDED :

Neoprene, Natural Rubber, SBR Rubber, Acrylic Paint, Lacquer, Varnish, Polystyrene, PVC, ABS, Polycarbonate, Cellulose Acetate, Low Nitrile Rubber (Buna N. NBR less than 36% Acrylonitrile), EPDM, Ethylene Vinyl Acetate, Latex, EPR, Acrylics, Phenoxy, Polysulfones, Styrene Acrylonitrile (San), Butyl.

### NOTICE

**All compressed air systems generate condensate which accumulates in any drain point (e.g. tanks, filters, drip legs, aftercoolers, dryers). This condensate contains lubricating oil and/or substances which may be regulated and must be disposed of in accordance with local, state, and federal laws and regulations.**

## ■ GENERAL REQUIREMENTS

The piping, fittings, air receiver tank, etc. must be certified safe for at least the maximum working pressure of the unit. Use hard-welded or threaded steel or copper pipes and cast iron fittings that are certified safe for the unit's discharge pressure and temperature. **DO NOT USE PVC PLASTIC IN THE COMPRESSED AIR DISCHARGE LINE.** Use pipe thread sealant on all threads, and make up joints tightly to prevent air leaks.

## ■ CONDENSATE DISCHARGE PIPING

If installing a condensate discharge line, the piping must be at least one size larger than the connection, as short and direct as possible, secured tightly and routed to a suitable drain point or waste container. Condensate must be disposed of in accordance with local, state, and federal laws and regulations.

### ⚠ WARNING

**If an aftercooler, check valve, block valve, or any other restriction is added to the compressor discharge, install a properly-sized ASME approved safety/relief valve between the compressor discharge and the restriction.**

## ■ ELECTRICAL CONNECTIONS

### ⚠ WARNING

**Electrical installation and service must be performed by a qualified electrician who is familiar with all applicable electrical codes.**

### ■ GENERAL

The motor rating, as shown on the motor nameplate, and the power supply must have compatible voltage, phase and hertz characteristics.

### ■ WIRE SIZE

Refer to the applicable electric codes in your area for information on selecting the proper wire size and securing electrical connections. Install adequately sized power leads to protect against excessive voltage drop during start-up. For distances exceeding 50ft it may be necessary to use larger wire to avoid any voltage drop.

### NOTICE

#### DO NOT USE UNDERSIZE WIRE

If wire size information is not available, the wire sizes shown in the following wire selection chart can be used as a safe guide, if the distance does not exceed 50 feet (15.3 m). For longer distances, consult and electrical contractor or the local electric company for recommendations.

MOTOR HP	SINGLE PHASE	
	115V	230V
5	4 (6)	8 (10)

Wire sizes shown in AWG (SWG):

- AWG = American Wire Gauge
- SWG = British Imperial Standard Wire Gauge

### ■ FUSES

Refer to applicable local codes to determine the proper fuse or circuit breaker rating required. When selecting fuses, remember the momentary starting current of an electric motor is greater than its full load current. Time Delay or "slow-blow" fuses are recommended.

## ■ GROUNDING INSTRUCTIONS

The ground terminal is located within the pressure switch. Ground must be established with a grounding wire sized according to the voltage and minimum branch circuit requirements printed on the compressor specifications decal. Ensure good bare metal contact at all grounding connection points, and ensure all connections are clean and tight.

Ground Symbol



### ⚠ WARNING

**Improper grounding can result in electrical shock and can cause severe injury or death. This product must be connected to a grounded, metallic, permanent wiring system or an equipment-grounding terminal or lead on the product. All grounding must be performed by a qualified electrician and comply with applicable electric codes.**

### NOTICE

**Verify grounding connections after initial installation and periodically thereafter to ensure good contact and continuity has been maintained. Consult with a qualified electrician or service technician if the grounding instructions are not completely understood, or if in doubt as to whether the product is properly grounded.**

### NOTICE

**DO NOT MANIPULATE THE CONDUIT OPENING FOR INCOMING POWER SUPPLY. The conduit opening is designed for the incoming power supply to be contained and secured within a 1/2" flexible conduit.**

## ■ PRESSURE SWITCH ELECTRICAL CONNECTIONS

(A) Incoming Power Leads

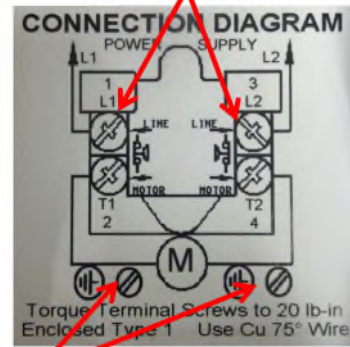

(B) Grounding Lugs

Ground wires not shown for clarity. Equipment must be properly grounded.

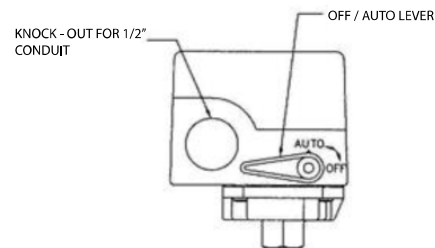

A = Incoming power leads (see notes 3 & 4)

B = Incoming grounding lug (see note 2)

1. Confirm that the supply voltage matches the voltage rating of the pressure switch (label can be found inside the cover of the pressure switch).
2. Connect the power supply to a properly grounded electrical circuit with specified voltage and fuse protection.
3. When connecting the incoming power wires to the pressure switch, ensure that the existing control circuit wires remain under the terminal pressure plates and are secure after tightening the screw terminals. Utilize the split ring terminal type of connector for the incoming power leads.
4. Refer to the torque values listed on side of the pressure switch when tightening the wire terminal screws.

■ **COMPRESSOR LUBRICATION**

**CAUTION**

**Do not operate without lubricant or with inadequate lubricant. Ingersoll Rand is not responsible for compressor failure caused by inadequate lubrication.**

■ **SYNTHETIC COMPRESSOR LUBRICANT**

**Ingersoll Rand** recommends All Season Select synthetic lubricant from start-up. See the WARRANTY for extended warranty information.

■ **ALTERNATE LUBRICANTS**

You may use XL-300 or a comparable petroleum-based lubricant that is premium quality, does not contain detergents, contains only anti-rust, anti-oxidation, and anti-foam agents as additives, has a flashpoint of 440°F (227°C) or higher, and has an auto-ignition point of 650°F (343°C) or higher.

See the petroleum lubricant viscosity table below. The table is intended as a general guide only. Heavy duty operating conditions require heavier viscosities. Refer specific operating conditions to **Ingersoll Rand** for recommendations.

Temperature Around Compressor		Viscosity at 100°F (37.8 °C)		Viscosity Grade	
°F	°C	SUS	Centistokes	ISO	SAE
< 40	< 4.4	150	32	32	10
40-80	4.4-26.7	500	110	100	30
80-125	26.7-51.0	750	165	150	40

If you use a petroleum-based compressor lubricant at start-up and decide to convert to All Season Select later on, the pump must be decarbonized and flushed before conversion. Contact **Ingersoll Rand** for more information.

■ **FILLING PROCEDURES:**

1. Unscrew and remove the oil fill plug.
2. Fill the crankcase with lubricant.
3. Replace the oil fill plug **HAND TIGHT ONLY**.

**CAUTION**

**Do not remove the oil fill plug while the compressor is running.**

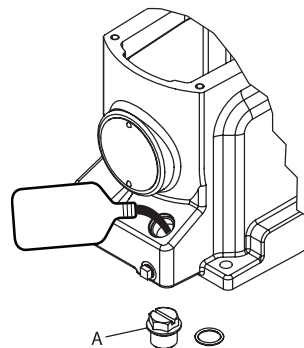

MODEL	CAPACITY
TS4 / 2200 (5 HP)	40 OZ (1.2 L)

Use one of the following methods illustrated to determine when the crankcase is full.

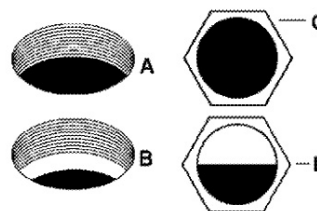

- **A = FULL level at bottom thread of oil fill opening on units without sight glass.**
- **B = ADD level below bottom thread of oil fill opening on units without sight glass.**
- **C = FULL level on units with sight glass.**
- **D = ADD level on units with sight glass.**

## OPERATION

### ■ START-UP

The Pressure Switch is Pre-set at the required pressure. The range and differential settings ARE NOT adjustable. The Pressure Switch should not be tampered with in any way and no attempt should be made to adjust the pressure settings as this could damage the Switch to the point of failure and/or void any warranty for the Pressure Switch.

1. Close the service valve.
2. Release any remaining tank pressure by slowly opening the manual drain valve.
3. Close the manual drain valve and apply power to the compressor. Pressure switch is equipped with an "ON/ AUTO-OFF" lever, flip the switch to the "ON/AUTO" position.

#### TYPICAL PRESSURE SWITCH LEVER

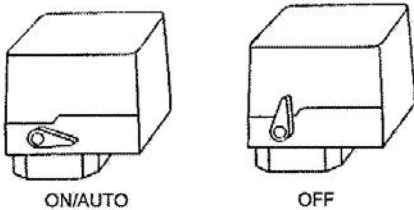

4. Slowly open the service valve.

### ■ OIL CONSUMPTION CHECK

A rule of thumb in determining a "passing grade" for oil consumption is to consider consumption at or above 50 horsepower-hours per ounce to be acceptable. The formula is as follows:

$$\frac{\text{Horsepower} \times \text{Hours of Operation}}{\text{Ounces of Oil Used}} = \frac{\text{Horsepower Hours}}{\text{per Ounce}}$$

To apply this formula, consider the size of the machine. In the following example, a 5 horsepower compressor uses 2 ounces of oil every 20 hours of operation.

$$\frac{5 \text{ Horsepower} \times 20 \text{ Hours of Operation}}{2 \text{ Ounces of Oil Used}} = 50 \frac{\text{Horsepower Hours}}{\text{per Ounce}}$$

The compressor in the example passes the oil consumption test.

#### NOTICE

**New or rebuilt compressor pumps will discharge higher than normal amounts of oil until the piston rings are seated (approximately 100 operating hours).**

## MAINTENANCE



### WARNING

Before performing maintenance, release air pressure from the system and disconnect, lock and tag the main power supply.

### NOTICE

All compressed air systems contain maintenance parts (e.g. lubricating oil, filters, separators) which are periodically replaced. These used parts may be, or may contain, substances that are regulated and must be disposed of in accordance with local, state, and federal laws and regulations.

### NOTICE

Take note of the positions and locations of parts during disassembly to make reassembly easier. The assembly sequences and parts illustrated may differ for your particular unit.

### NOTICE

Any service operations not explained in this manual should be performed by an authorized service representative.

### NOTICE

The following maintenance schedule has been developed for typical applications. Maintenance intervals should be shortened in harsher environments.

### MAINTENANCE SCHEDULE

Daily or Before Each Operation	Check for oil leaks
	Check lubricant level. Fill as needed.
	Test drain valve for proper operation. Clean if needed.
	Drain receiver tank condensate (if automatic draining device is not provided). Open manual drain valve and collect and dispose of condensate accordingly.
	Check for unusual noise and vibration.
	Ensure beltguards and covers are securely in place.
Weekly	Ensure area around compressor is free from rags, tools, debris, and flammable or explosive materials.
	Observe operation of safety/relief valves while the compressor is running. Replace safety/relief valves that do not operate freely.
Monthly	Inspect air filter element(s). Clean if necessary.
	Inspect for air leaks. Squirt soapy water around joints during compressor operation and watch for bubbles.
	Clean drain valve.
	Check tightness of screws and bolts.
	Tighten as needed.
3/500 "	Inspect drive belts. Adjust if necessary.
	Clean exterior.
	Change petroleum lubricant while crankcase is warm.
12/2000 "	Drain compressor oil and clean oil sight glass.
	Replace filter element.
" indicates months/operating hours, whichever occurs first.	

## ■ FILTER INSPECTION & CLEANING

1. Unscrew and remove the wing nut (A) securing the filter housing (B) to its base (C).
2. Remove the filter housing and withdraw the old filter element (D). Clean the element with a jet of air or vacuum.
3. Replace the filter element and housing, securing it in place with the wing nut previously removed.

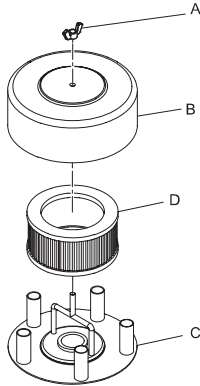

## ■ OIL CHANGE

1. Remove the oil drain plug (A) and allow the lubricant to drain into a suitable container.

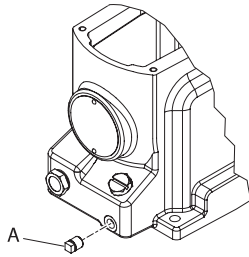

2. Replace the oil drain plug.
3. Follow the filling procedures in OPERATION section.

## ■ BELT ADJUSTMENT

### • CHECKING BELT TENSION

Check belt tension should be occasionally, especially if looseness is suspected. New belts must also be properly tensioned upon installation.

### • TENSIONING BELTS

Belt tensioning can be achieved by loosening the motor anchor screws, pushing the motor away from the pump, and retightening the motor anchor screws. The motor can be easily moved by placing a prying tool beneath it. A commercially available spreader or other belt tensioning device can also be helpful.

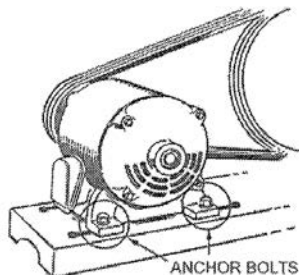

Follow the procedures outlined below to correctly set and measure belt tension. Refer to the following illustration for a visual representation.

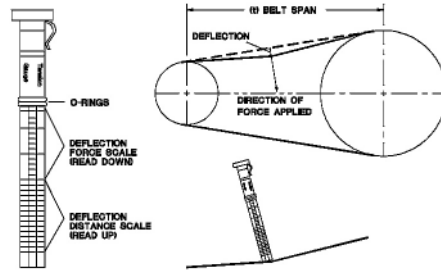

1. Lay a straight edge across the top outer surface of the belt drive from pulley to sheave.
2. At the center of the span, perpendicular to the belt, apply pressure to the outer surface of the belt with a tension gauge. Force the belt to the deflection indicated in the BELT TENSION TABLE in the DIAGRAMS & TABLES section. Compare the reading on the tension gauge to the table.

Ensure the pulley and sheave are properly aligned and the motor anchor screws are adequately retightened prior to restarting the compressor.



### CAUTION

**Improper pulley/sheave alignment and belt tension can result in motor overload, excessive vibration, and premature belt and/or bearing failure.**

To prevent these problems from occurring, ensure the pulley and sheave are aligned and belt tension is satisfactory after installing new belts or tensioning existing belts.

## ■ TANK INSPECTION

The life of an air receiver tank is dependent upon several factors including, but not limited to, operating conditions, ambient environments, and the level of maintenance. The exact effect of these factors on tank life is difficult to predict; therefore, Ingersoll-Rand recommends that you schedule a certified tank inspection within the first five years of compressor service. To arrange a tank inspection, contact **Ingersoll Rand**.

If the tank has not been inspected within the first 10 years of compressor service, the receiver must be taken out of service until it has passed inspection. Tanks that fail to meet requirements must be replaced.



### WARNING

**Failure to replace a rusted air receiver tank could result in air receiver tank rupture or explosion, which could cause substantial property damage, severe personal injury, or death. Never modify or repair tank. Obtain replacement from service center.**

## TROUBLESHOOTING

PROBLEM	CHECK POINT
Abnormal piston, ring or cylinder wear	4, 8, 9, 19, 25, 33
Air delivery drops off	1, 6, 15, 16, 18, 19, 26
Automatic drain valve leaks or does not drain automatically	16
Broken intercooler or aftercooler tubes	33
Compressor does not come up to speed	2, 6, 12, 15, 21
Compressor is slow to come up to speed	24, 30, 31
Compressor runs excessively hot	3, 14, 15, 22
Compressor will not unload when stopped	30
Excessive noise during operation	2, 6, 15, 16, 24
Excessive starting and stopping	5, 16, 29, 34
Knocks or rattles	2, 15, 17, 19, 20, 21
Lights flicker or dim when running	12, 13
Moisture in crankcase or "milky" appearance in petroleum lubricant or rusting in cylinders	9, 10
Motor overload trips or draws excessive current	5, 6, 12, 13, 14, 15, 16, 19, 20, 21, 31
Oil in discharge air (oil pumping)	4, 7, 9, 18, 19, 23, 32
Oil leaking from shaft seal	23
Safety/relief valve "pops"	1, 5, 26, 27
High interstage pressure	27
Low interstage pressure	28
Motor will not start	12
Oil Leaks	35

CHECK POINT	POSSIBLE CAUSE	POSSIBLE SOLUTION
1	Clogged or dirty inlet and/or discharge line filter.	Clean or replace.
2	Loose beltwheel or motor pulley, excessive end play in motor tension and shaft or loose drive belts.	Check beltwheel, motor pulley, crankshaft, drive belt alignment. Repair or replace as required.
3	Inadequate ventilation around beltwheel.	Relocate compressor for better air flow.
4	Lubricant viscosity too low.	Drain existing lubricant and refill with proper lubricant.
5	Air leaks in air discharge piping.	Check tubing and connections. Tighten joints or replace as required.
6	Lubricant viscosity too high.	Drain existing lubricant and refill with proper lubricant.
7	Lubricant level too high.	Drain excess lubricant.
8	Lubricant level too low.	Add lubricant to crankcase to proper level.
9	Detergent type lubricant being used.	Drain existing lubricant and refill with proper lubricant.
10	Extremely light duty cycles.	Run compressor for longer duty cycles.
	Compressor located in damp or humid location.	Relocate compressor or install crankcase heater kit.

CHECK POINT	POSSIBLE CAUSE	POSSIBLE SOLUTION
12	Improper line voltage.	Check line voltage and upgrade lines as required. Contact electrician.
	Wiring or electric service panel too small.	Install properly sized wire or service box. Contact electrician.
	Poor contact on motor terminals or starter connections.	Ensure good contact on motor terminals or starter connections.
	Improper starter overload heaters.	Install proper starter overload heaters. Contact electrician
13	Poor power regulation (unbalanced line).	Contact power company.
14	Drive belts too tight or misaligned.	Adjust belts to proper tension and alignment.
15	Compressor valves leaky, broken, carbonized or loose.	Inspect valves. Clean or replace as required.
		Install Valve/Gasket Step Saver Kit.
16	Automatic drain valve clogged, leaking or defective.	Inspect valve and clean, repair or replace as required.
17	Carbon build-up on top of piston(s).	Clean piston(s). Repair or replace as required.
18	Piston rings damaged or worn (broken, rough or scratched).	Install Ring/Gasket Step Saver Kit.
	Excessive end gap or side clearance.	Adjust piston rings.
	Piston rings not seated, are stuck in grooves or end gaps not staggered.	
19	Cylinder(s) or piston(s) scratched, worn or scored	Repair or replace as required.
20	Connecting rod, piston pin or bearings worn or scored. Loose bearing spacer on crankshaft.	Inspect all. Repair or replace as required. Install Bearing/ Connecting Rod Step Saver Kit.
21	Defective ball bearings on crankshaft or motor shaft.	Inspect bearings and replace if required. Install Bearing/ Connecting Rod Step Saver Kit.

CHECK POINT	POSSIBLE CAUSE	POSSIBLE SOLUTION
22	Wrong beltwheel direction of rotation.	Check motor wiring for proper connections. Reverse two leads on three-phase motors.
23	Crankshaft seal worn or crankshaft scored.	Replace seal. Install shaft sleeve if required. Install Bearing/ Connecting Rod Step Saver Kit.
24	Leaking check valve or check valve seat blown out.	Replace check valve.
25	Extremely dusty atmosphere.	Install remote air inlet piping and route to source of cleaner air. Install more effective filtration.
26	Defective safety/relief valve.	Replace.
27	High pressure inlet valve leaking.	Inspect, clean or repair as required.
28	Low pressure discharge valve leaking.	Inspect, clean or repair as required.
29	Post Discharge Air Leak.	Check downstream lines and tools for air leaks.
30	Pressure switch unloader leaks or does not work.	Realign stem or replace.
31	Ambient temperature too low.	Install crankcase heater kit. Convert to All Season Select lubricant. Relocate compressor to warmer environment.
32	Worn cylinder finish.	Deglaze cylinder with 180 grit flex-hone.
33	Beltwheel out of balance, tubes not braced or secured, wrong pulley speed.	Check vibration level, change pulley or beltwheel if required, tighten tube clamps.
34	Excessive condensate in receiver tank.	Drain receiver tank with manual drain valve or install automatic drain valve.
35	Loose fittings/elbows/connectors.	Re-torque fittings per specified torque requirements.

**DIAGRAMS & TABLES**

<b>FASTENER TORQUE TABLE</b>	
<b>FASTENER LOCATION</b>	<b>TORQUE</b>
Valve Assembly	5 FT. LB. (6.8 NM)
End Cover Assy	102-106 IN. LB. (11.5-12 NM)
Connecting Rod	16-18 FT. LB. (22-24.5 NM)
Head Bolt	21-23 FT. LB. (28.5-31 NM)
Cylinder Flange	21-23 FT. LB. (28.5-31 NM)
Beltwheel	21-23 FT. LB. (28.5-31 NM)
Low Oil Level Switch Baffle	102-106 IN. LB. (11.5-12 NM)

<b>BELT TENSION TABLE</b>			
<b>MODEL</b>	<b>DEFLECTION IN.</b>	<b>MIN. LBS TENSION</b>	<b>MAX. LBS TENSION</b>
TS4 / 2200 (5HP)	.25	4.9	7.1

■ ELECTRICAL WIRING DIAGRAMS

■ SINGLE PHASE WIRING

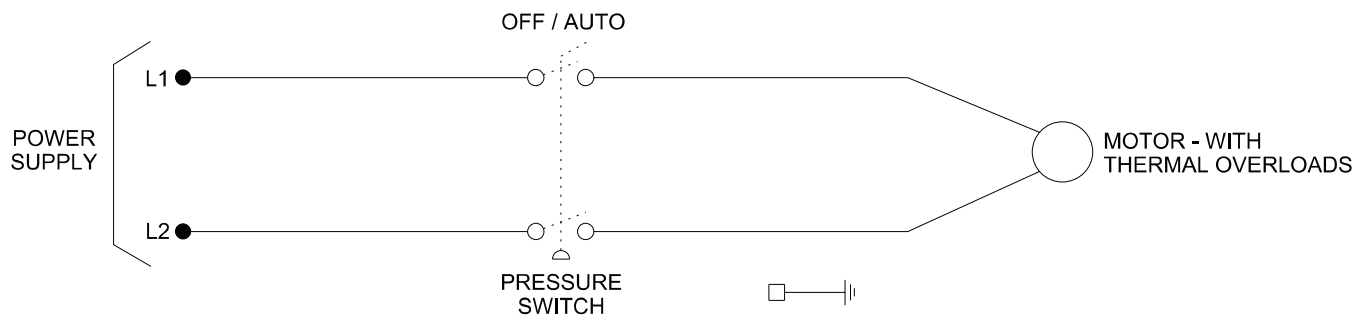

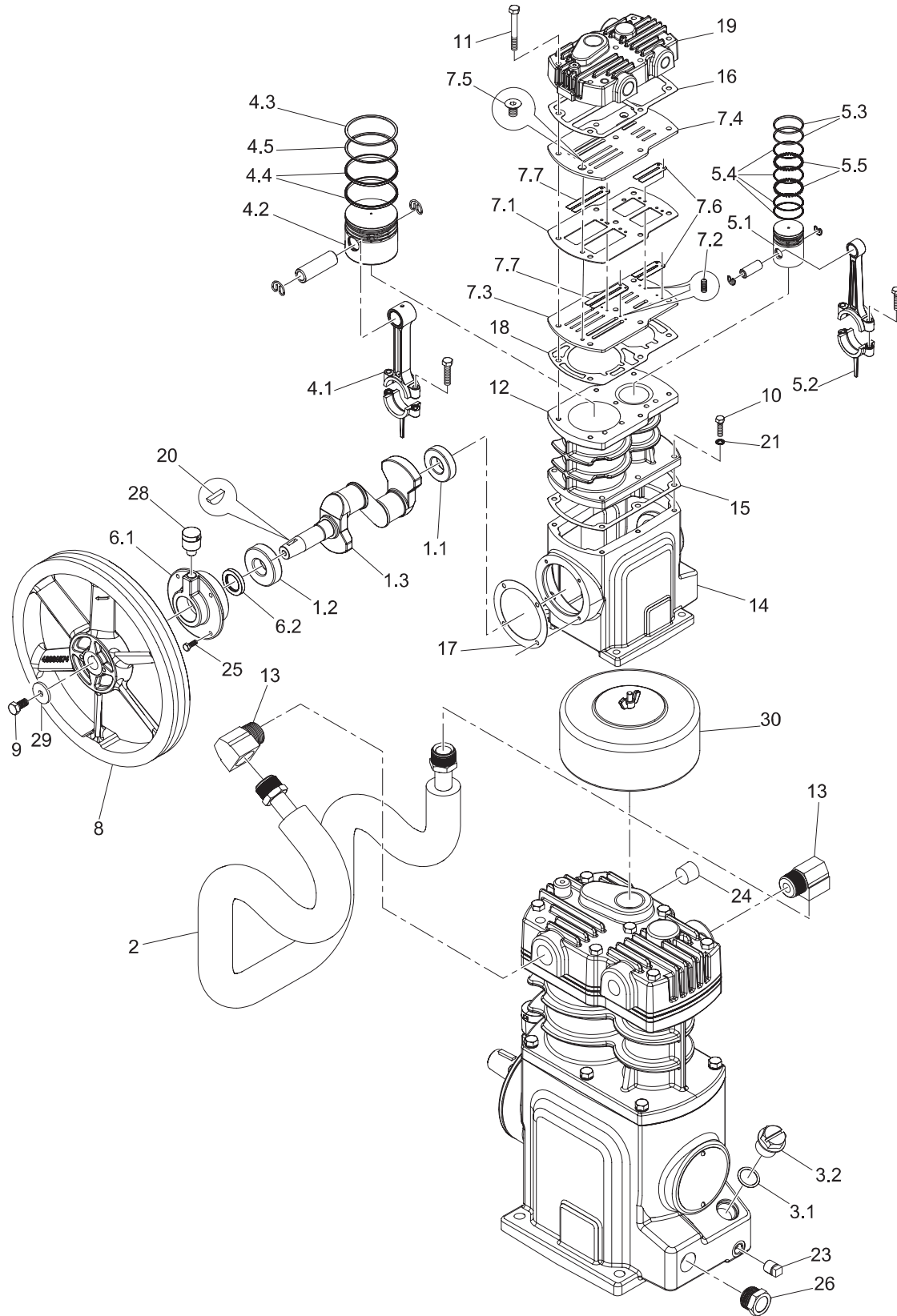

	ITEM	CCN	QTY	DESCRIPTION
	1	97334155	1	CRANKSHAFT ASSEMBLY
◆○	1.1	95200630	1	BEARING
◆○	1.2	95213914	1	BEARING
	1.3	97333462	1	CRANKSHAFT
	2	85581494	1	TUBE ASSEMBLY
	3	97334254	1	PLUG
■●○	3.1	97334288	1	'O' RING
	3.2	97334296	1	PLUG
	4	85587558	1	ASSEMBLY, PISTON/ROD - LP
◆○	4.1	97333173	1	ASSEMBLY, CONNECTING ROD - LP
	4.2	85585925	1	ASSEMBLY, PISTON/PIN - LP
■○	4.3-4.5	85581452	1	RING SET, LOW PRESSURE
■○	4.3	NSS	1	RING, BARREL COMP.
■○	4.4	NSS	2	RING, OIL CONTROL - PIECE
■○	4.5	NSS	1	RING, TAPER FACE
	5.0	22226070	1	ASSEMBLY, PISTON/ROD - HP
	5.1	85583045	1	ASSEMBLY, PISTON/PIN - HP
◆○	5.2	85583060	1	ASSEMBLY, CONNECTING ROD - HP
■○	5.3-5.5	85581460	1	RING SET, HIGH PRESSURE
■○	5.3	NSS	2	RING, COMPRESSION
■○	5.4	NSS	4	RING, OIL CONTROL RAIL
■○	5.5	NSS	2	RING, OIL CONTROL SPACER
	6	97334247	1	COVER ASSEMBLY
	6.1	97334262	1	COVER
◆○	6.2	97335624	1	SEAL
□○	7	85582666	1	ASSEMBLY, VALVE
□○	7.1	85582658	1	GASKET
□○	7.2	96730650	8	DOWEL
□○	7.3	85582641	1	PLATE, DISCHARGE
□○	7.4	85582633	1	PLATE, INLET
□○	7.5	96720180	2	SCREW
□○	7.6	85582625	2	VALVE, FINGER
□○	7.7	85582617	2	VALVE, FINGER
	8	24859761	1	BELT WHEEL
	9	96730437	1	CAPSCREW
	10	96705868	6	SCREW
	11	96706874	7	BOLT, HEAD
	12	54632302	1	CYLINDER
	13	95031761	2	ELBOW
	14	54739396	1	BODY
■◆●○	15	97333546	1	GASKET, CYLINDER
□●○	16	54632450	1	GASKET, HEAD
◆●○	17	97333843	1	GASKET
□●○	18	85584332	1	GASKET, VALVE PLATE
	19	54657002	1	HEAD

◆○	20	95245494	1	KEY, WOODRUFF
	21	96728316	6	WASHER, SPRING
	23	95033593	1	PLUG
	24	95928230	1	PLUG
	25	96705777	4	SCREW
	26	97334270	1	SIGHT-GLASS
	28	70243936	1	VENT, FRAME
	29	54423504	1	WASHER
	30	32170953	1	ASSEMBLY, FILTER (INCLUDES ELEMENT 32170979)

- AVAILABLE IN VALVE KIT 85584316
- AVAILABLE IN PISTON RING KIT 85580470
- ◆ AVAILABLE IN BEARING/CONNECTING ROD KIT 85581445
- AVAILABLE IN OVERHAUL KIT 85581486
- AVAILABLE IN GASKET KIT 85581478

NSS NOT SOLD SEPARATELY

**ALL SEASON SELECT COMPRESSOR LUBRICANT**

CCN	DESCRIPTION
97338131	(1) 0.5L BOTTLE
38436721	(1) 1.0L BOTTLE

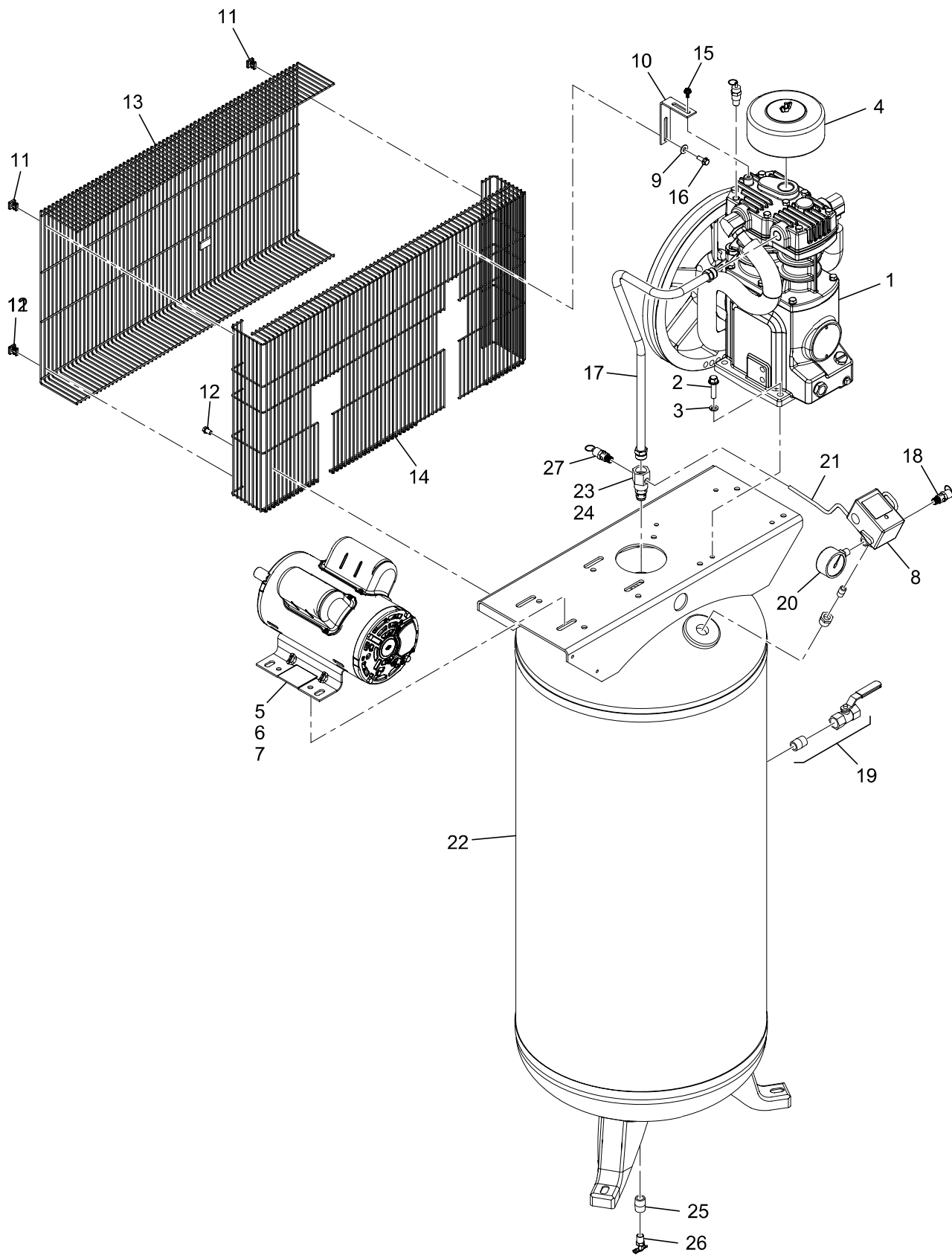

REF NO	PART NO.	DESCRIPTION	QTY
<b>BARE PUMP GROUP</b>			
1	22235923	PUMP, BARE COMPRESSOR	1
2	96701917	SCREW, HEX HD M10X30	4
3	96718655	WASHER SPRING LOCKTYPE	4
<b>AIR INTAKE FILTER GROUP</b>			
4	32170953	FILTER AIR INLET	1
<b>MOTOR GROUP</b>			
5	47733923001	MOTOR, 230-1-60	1
<b>SHEAVE &amp; BELT GROUP</b>			
6	32184376	SHEAVE (2200L5)	1
	22194724	SHEAVE (TS4N5)	
7	95099461	BELT	1
<b>CONTROLS GROUP</b>			
8	23474653	SWITCH, PRESSURE - 230-1-60	1
<b>BELTGUARD GROUP</b>			
9	14084123	WASHER	5
10	47761112001	BRACE	1
11	32496093	CLIP	4
12	36797652	SCREW	4
13	54416730	BELTGUARD, BACK	1
14	54416748	BELTGUARD, FRONT	1
15	56280159	SCREW, HEX SERRATED	1
16	96704531	SCREW, SERRATED M6X16	1
<b>DISCHARGE TUBE GROUP</b>			
17	47837644001	DISCHARGE TUBE - 60 GAL. TANK (2200L5)	1
	54671771	DISCHARGE TUBE - 80 GAL. TANK (TS4N5)	
<b>AIR RECEIVER TANK GROUP</b>			
18	31385693	VALVE, SAFETY/RELIEF - 200 PSIG	1
19	32223588	ASSEMBLY, BALL VALVE	1
20	23474901	GAUGE, PRESSURE	1
21	46820304	UNLOADER TUBE ASSEMBLY	1
22	23562713	TANK, 60 GALLON AIR RECEIVER (2200L5)	1
	23686900	TANK, 80 GALLON AIR RECEIVER (TS4N5)	
23	85582229	VALVE, CHECK	1
24	95691077	NIPPLE - 3/8W X 1L	1
25	95417507	NIPPLE - 1/2W X 1-1/8L	1
26	32027120	VALVE. MANUAL DRAIN	1
<b>SAFETY/RELIEF VALVE GROUP</b>			
27	32174286	VALVE, SAFETY/RELIEF - 325 PSIG DISCHARGE	1



A series of horizontal lines for writing, spanning the width of the page. The lines are evenly spaced and extend from the left margin to the right edge of the page. There are 25 lines in total, starting from the top margin and ending at the bottom margin.



A series of horizontal lines for writing, consisting of 25 evenly spaced lines that span the width of the page.

