



**PSG Series
OIL/WATER SEPARATORS**

**INSTALLATION, OPERATION,
MAINTENANCE MANUAL AND
PARTS LIST**

FAILURE TO READ AND UNDERSTAND THE FOLLOWING INSTRUCTIONS MAY CAUSE YOU UNNECESSARY COMPLICATIONS IN THE INSTALLATION OR OPERATION OF THIS EQUIPMENT.

More Than Air. Answers.

Online answers: <http://www.ingersollrandproducts.com>
PHONE: 1-800-AIR-COMP (1-800-247-2667)

C.C.N. : 38471157
REV. : B
DATE : June 2011

Limited One Year Warranty

The PSG Separators are warranted to be free from defects in material and workmanship, under proper use, installation, application, and maintenance in accordance with the manufacturer's written recommendations and specification for a period of 18 months from the date of shipment from the factory or 12 months from the date of installation, whichever comes first. The manufacturer's obligation under this warranty is limited to, and the sole remedy for any such defect shall be, the repair or replacement (at manufacturer's option) of unaltered products returned to manufacturer within stated period.

In order to process a claim, Ingersoll-Rand must get from the customer a proof of purchase (date of purchase, invoice number). In no event, shall Ingersoll-Rand be liable for business interruptions, loss of profits, personal injury, costs of delay or any other special, indirect, incidental, or consequential losses, cost, or damages.

NOTE - Routine maintenance and minor adjustments to the Ingersoll-Rand oil/water separators are not covered under this warranty. Prior to performing any possible warranty service or replacing a possible warranted part, please contact your local Ingersoll-Rand authorized representative. All warranty claims must be performed by an Ingersoll-Rand certified technician. Failure to comply with this procedure will result in denial of warranty claim.

TABLE OF CONTENTS

1.0 GENERAL

2.0 HOW IT WORKS

3.0 INSTALLATION INSTRUCTIONS

3.1 Placement

3.2 Filter Preparation

3.3 Water Outlet Plumbing Preparation

3.4 Condensate Inlet Preparation

3.5 Collection Manifold Guidelines

3.6 Priming The System

3.7 Oil Outlet Tube Adjustment

3.8 Sample Testing

3.9 Commissioning

4.0 OPERATION INSTRUCTIONS

5.0 MAINTENANCE INSTRUCTIONS

5.1 Maintenance Schedule

5.2 Diffuser and Separation Filter Maintenance Procedure

5.3 Pre-Adsorber and Adsorption Module Replacement Procedure

6.0 SIZING

7.0 TROUBLESHOOTING

8.0 GENERAL DATA

9.0 PARTS LIST

Performance Statement for Ingersoll Rand

Polysep PSG Series

The Polysep PSG Series is designed to separate a wide variety of compressor lubricants from compressor condensate. PSG separators use gravity separation to float and remove lubricants which separate easily and do not emulsify. Stable emulsions, such as polyglycol based lubricants, are broken and removed by the absorption filter modules incorporated in the PSG.

For lubricants which do not form stable emulsions, the PSG Series separators are designed to remove oil from compressor condensate to a level of less than or equal to 10mg/liter (as per US EPA Method 1664 Oil & Grease).

For lubricants which form stable emulsions, the PSG Series separators are designed to remove over 95% of lubricant present in the incoming compressor condensate.

This level of performance is obtainable only if the following conditions are met:

1. Installation, commissioning, and operation are done strictly following the instructions in the installation and maintenance manual provided with the unit.
2. The sizing of the PSG separator is done using only the manufacturer's software or technical information and all of the required parameters are verified.
3. The actual operating conditions and lubricant of the compressed air plant are verified to be identical to those provided for sizing.
4. There must be no mixing of oils or introduction of other materials in the condensate sent to the PSG unit.
5. The filter modules are replaced according to the schedule in the maintenance manual and are properly installed.
6. The compressor is optimized according to the manufacturer's recommended maintenance and inspection schedule (namely separator assembly).

1.0 GENERAL

The separator provides an environment where the small percentage of an insoluble lubricant can rise to the surface to be skimmed off. Water that is displaced by fresh incoming condensate slowly sinks to the bottom, and then rises to pass through the unique polar Adsorption Module. From there, the clean water can be safely discharged to your collection point.

2.0 HOW IT WORKS

(1) Depressurization: Condensate is depressurized as it enters the separator through the three (3) ½" NPT Condensate Inlets in the Inlet Diffuser Assembly. Air is exhausted to atmosphere through the Filter located in the top. Gravity draws the new condensate into the Sediment Chamber and pushes the old condensate through the Separation Filter. The Separation Filter causes fine oil droplets to coalesce which speeds up

the separation process. It also prevents the dirt, rust and scale from leaving the Sediment Chamber.

(2) Processing: Both the Oil and Water enter the Vessel through exit holes in the Sediment Chamber. Non emulsified oil will float to the surface and then be removed via the Oil Outlet Tube to the Oil Container. The Water slowly sinks to the bottom of the Vessel. It rises through a tube and enters the Pre-Adsorption Chamber where it is pre-cleaned before it flows down through the Adsorption Module for final polishing. From there it exits the separator via the Water Outlet Port located conveniently at the back of the vessel.

(3) Monitoring: A translucent Oil Container is provided to indicate just how much oil has collected for disposal.

Sample Jars are provided to collect water from the Sample Valve. A simple comparison test will confirm when it's time to change the Adsorption Module.

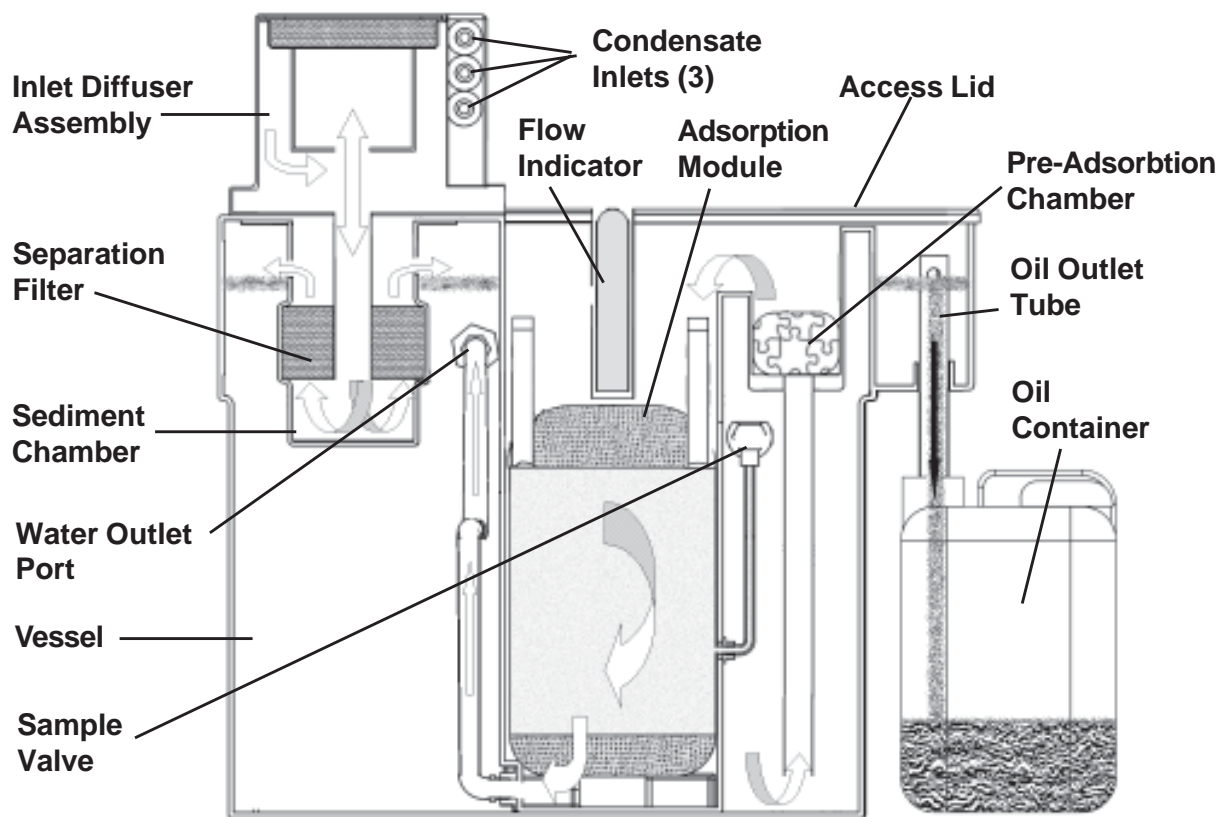

3.0 INSTALLATION INSTRUCTIONS

3.1 PLACEMENT

The separator must be installed on a flat and level surface capable of supporting the entire functioning weight of the installation. As gravity is responsible for the proper operation of the separator, it is highly recommended that the unit be installed close to the collection point for the treated condensate. Please provide room around the unit for ease of maintenance and access to the filters.

1. Level the floor area where the separator will be placed to ensure proper operation.
2. Twist the external OIL OUTLET TUBE while raising it to its maximum height.
3. Position the translucent OIL CONTAINER below the OIL OUTLET TUBE.

DO NOT LOWER OIL OUTLET TUBE AT THIS TIME.

IMPORTANT: AMBIENT TEMPERATURE MUST BE BETWEEN 35°F (2°C) AND 120°F (48°C).

IMPORTANT: MAXIMUM DRAIN INLET PRESSURE IS 250 PSIG (17 bar)

NOTE: FLOW DIVIDER OPTION. When using multiple separator units, centrally locate the Flow Divider (CCN 2204432) to ensure uniform distribution.

The Flow Divider (CCN 2204432) must be installed securely above the separator units to ensure proper operation. Please consult the Flow Divider (CCN 2204432) installation instruction section for further details.

3.2 FILTER PREPARATION

The Pre-Adsorber and Adsorption Module are shipped from the factory in plastic shipping bags to control dust and placed in their respective compartments.

The following pre-wetting procedure removes dust created during shipping and reduces the likelihood of air pockets.

1. Remove the Access Lid, Pre-Adsorber, and Adsorption Module from the separator unit.
2. Remove the plastic shipping bags from the Pre-Adsorber and Adsorption Module.
3. Thoroughly hose-down the Pre-Adsorber and Adsorption Module with fresh water while gently rolling until the rinse water runs clear.

CAUTION: FAILURE TO THOROUGHLY PRE-WET THE ADSORPTION MODULE MAY LEAVE AIR TRAPPED AND RESULT IN THE ADSORPTION MODULE FLOATING.

4. Reinstall the pre-wetted Pre-Adsorber and Adsorption Module.

Note: For ease of installation, roll the Adsorption Module on the floor to elongate it. Pick-up the module in both hands and carry horizontally. Position the end of the module at the top of the chamber and gently tip up and slide into the chamber. Finally, press down on the edges of the module to ensure it is fully installed and seated at the bottom of the chamber.

3.3 WATER OUTLET PLUMBING PREPARATION

The size and location of the Water Outlet fitting will control the water level in the separator.

1. Install a ¾" NPT elbow on the Water Outlet Port facing downward and route piping directly to the collection point to limit any flow restriction.

CAUTION: DO NOT RESTRICT OR REDUCE THE SIZE OF THE WATER OUTLET PIPING. RESTRICTING THE WATER OUTLET CAN RESULT IN DISCHARGING WATER INTO THE OIL CONTAINER.

NOTE: When using a common water outlet manifold, install an elbow on the Water Outlet Port of each separator facing downward. All piping and manifold must be lower than the height of the outlet and be pitched toward the collection point.

3.4 CONDENSATE INLET PREPARATION

The INLET DIFFUSER can be rotated by 90° or 180° to ease installation. To rotate the DIFFUSER follow steps 1-3, otherwise proceed to step 4.

1. Remove the four (4) socket head cap screws attaching the INLET DIFFUSER to the separator.
2. Rotate DIFFUSER to the desired position.
3. Reinstall the four (4) socket head cap screws and tighten.
4. Use flexible tubing to connect the condensate sources to the Inlet Connections on the INLET DIFFUSER.
5. Refer to COLLECTION MANIFOLD GUIDELINES for installation of multiple drain lines.

NOTE: The use of a Flow Divider (CCN 2204432) is recommended when demand style condensate drains can collectively deliver more than 43 ounces.

3.5 COLLECTION MANIFOLD GUIDELINES

Collection Manifolds permit several condensate drain sources to be combined into a single stream and one connection to the separator or Flow Divider (CCN 2204432). The following suggestions are offered for the design and installation of a Collection Manifold.

1. Use 1" minimum pipe to limit flow restrictions.
2. Use the bottom inlet connection of the INLET DIFFUSER or Flow Divider (CCN 2204432).

3. Use a chemical and corrosion resistant piping and fittings, such as PVC or copper.
4. Locate the manifold at an elevation above the separator or Flow Divider (CCN 2204432). The manifold should slope in the direction of flow.
5. Secure the manifold to isolate the separator or Flow Divider (CCN 2204432) from pipe loads.
6. Condensate drain lines should enter the Collection Manifold from the top and at intervals no closer than one foot.
7. Provide a separate connection point for each drain source.

3.6 PRIMING THE SYSTEM

The specific gravity differential between the water and the lubricant is an important factor influencing separation.

Filling the separator with fresh, clean tap water before commissioning prepares the unit for proper operation.

1. Use fresh, clean tap water to fill the separator through the opening surrounding the Oil Outlet Pipe.

CAUTION: TO PREVENT OVERFLOWING, REDUCE THE FLOW WHEN WATER BEGINS TO SPILL INTO THE ADSORPTION MODULE

2. The unit is primed when clear water begins to flow from the Water Outlet.
3. Allow the unit to sit for five (5) minutes to balance the water level before proceeding to Oil Outlet Tube Adjustment.

3.7 OIL OUTLET TUBE ADJUSTMENT

The Oil Outlet Tube extends up into the separator vessel to remove oil from the liquid surface. When sufficient oil has accumulated, it will be skimmed off of the surface and drained into the Oil Container via the Oil Outlet Tube.

1. Locate the Oil Container under the Oil Outlet Tube.
2. Grasp the Oil Outlet Tube with one hand and begin to lower the top of the tube by gently twisting the tube back and forth.
3. Lower the Oil Outlet Tube to an elevation with the top of the tube approximately ½" above the water level.

NOTE: It may take several months or more to collect enough oil in the separator for it to begin draining into the Oil Container. This is normal!

3.8 SAMPLE TESTING

Two (2) Sample Jars are included to provide a comparative method of testing to ensure the separator is operating properly.

1. Fill one (1) of the Sample Jars with clean tap water. This will be used as a reference.
2. The second Sample Jar will be used to collect a sample from the separator Sample Outlet.

3. Clean the Sample Jar thoroughly after sampling, empty and dry.
4. Store the Sample Jars in the Placement Wells molded into the top of the separator.
5. Refer to the MAINTENANCE INSTRUCTIONS for additional sampling details.

3.9 COMMISSIONING

The separator is now ready for operation.

4.0 OPERATION INSTRUCTIONS

Do not pour condensate, oil, or any other fluid directly into the oil/water separator.

Weekly, collect a sample of the discharge water in a clear glass vessel and, compare it to tap water, checking for cloudiness.

Replace the Adsorption Module when cloudiness appears in the discharge water sample.

For detailed analysis, contact your local authority or an approved testing laboratory. Ingersoll-Rand provides fluid testing services. To learn more about the services, please contact your local Ingersoll-Rand service provider.

5.0 MAINTENANCE INSTRUCTIONS

5.1 MAINTENANCE SCHEDULE

Daily

1. Check the Oil level in the translucent Oil Container. Empty it when the oil level reaches 3/4 of capacity.

Every Two Weeks

1. Take the empty Sample Jar and collect a sample from the Sample Valve located above the Oil Container.
2. Hold both the Sample Jar and the Reference Jar to a light for a visual turbidity comparison.
3. Keep a spare Pre-Adsorber and Adsorption Module in stock to avoid change out problems.
4. Change the Pre-Adsorber and Adsorption Module when the compared Condensate Sample appears cloudy.
5. Pour the Condensate Sample back into the Pre-Adsorber Chamber.
6. Wash and dry the Sample Jar before returning it to the Placement Well.

Note: The Sample Valve extracts the condensate sample 2/3rds of the way through the Adsorption Module. This provides enough time and security for replacing the Adsorption Module before PPM violations should occur.

Annually

Keeping your separator in good working condition prevents problems and pays you dividends all year long. Therefore, as part of a good preventative maintenance program, we recommend cleaning out the Sediment Chamber and replacing the Adsorption Module at least once a year. The following sections will provide you with these servicing details.

5.2 DIFFUSER AND SEPARATION FILTER MAINTENANCE PROCEDURE

The cleanliness of your piping will dictate how frequently you will need to perform this procedure. However, we recommend an annual cleaning to maintain the flow and to remove the dirt, rust and scale that has accumulated.

1. Shut off condensate flow to Inlet Diffuser Assembly.
2. Unscrew the four Socket Head Cap Screws that hold the Diffuser to the Vessel.
3. Lift up the Diffuser and move it out of the way so you can remove the Sediment Chamber.
4. Grasp the edges of the Sediment Chamber and slowly lift it from the vessel.
5. Tip the Sediment Chamber slightly to slowly pour the contents through the Separation Filter and back into the vessel until the liquid is emptied.
6. Remove the Separation Filter from the recess inside the Sediment Chamber and discard.
7. Clean the dirt, rust and scale from the Sediment Chamber. Reinstall a new Separation Filter into the recess.
8. Seat the Sediment Chamber into the vessel by slowly pouring tap water into it until the water exits the discharge holes in the Chamber walls.
9. Remove and replace the Expansion Chamber element located on top of the Diffuser Assembly.
10. Reinstall the Diffuser Assembly and secure with four socket head screws.

5.3 PRE-ADSORBER AND ADSORPTION MODULE REPLACEMENT PROCEDURE

Prepare the replacement Adsorption Module and Pre-Adsorber for service as follows:

1. Remove them from their plastic bags.
2. Thoroughly hose down the Pre-Adsorber & Adsorption Module while rolling them until the water runs clear.
3. Shut off the condensate flow to the Inlet Diffuser Assembly and remove the Access Lid.
4. Use a polypropylene pad to adsorb and remove any oil that is floating on the surface water in the Adsorption Module Chamber.
5. Grab Adsorption Module Handles and slowly lift out of chamber.
6. Suspend bag over chamber for a couple of minutes to drain.
7. Install new Pre-Adsorber & Adsorption Module.
8. Reorder a spare Pre-Adsorber & Adsorption Module.

ATTENTION: PLEASE BE SURE TO COMPLY WITH ALL APPLICABLE REGULATIONS WHEN DISPOSING OF LUBRICANT CONTAMINATED FILTERS.

6.0 SIZING

Cold Climate: 60°F (15°C), 60% RH							
IR Model	Compressor Capacity (CFM)						
	Screw Compressors					Reciprocating Compressors	
	Turbine Oil	Synthetic Oil	Polyglycol	PAO	Ester	Turbine Oil	Diester
PS-7	60	60	60	60	60	60	60
PSG-15	850	640	175	850	640	425	361
PSG-30	1,700	1,275	390	1,700	1,275	850	723
PSG-60	3,400	2,550	750	3,400	2,550	1,700	1,445
PSG-90	5,100	3,825	950	5,100	3,825	2,550	2,168
PSGK-120	6,800	5,100	1,500	6,800	5,100	3,400	2,890
PSGK-180	10,200	7,650	1,900	10,200	7,650	5,100	4,335

Mild Climate: 80°F (27°C), 60% RH							
IR Model	Compressor Capacity (CFM)						
	Screw Compressors					Reciprocating Compressors	
	Turbine Oil	Synthetic Oil	Polyglycol	PAO	Ester	Turbine Oil	Diester
PS-7	60	60	60	60	60	60	60
PSG-15	450	340	175	450	340	225	191
PSG-30	900	685	390	900	685	450	383
PSG-60	1,800	1,370	750	1,800	1,370	900	765
PSG-90	2,700	2,050	950	2,700	2,050	1,350	1,148
PSGK-120	3,600	2,740	1,500	3,600	2,740	1,800	1,530
PSGK-180	5,400	4,100	1,900	5,400	4,100	2,700	2,295

Hot Climate: 90°F (32°C), 70% RH							
IR Model	Compressor Capacity (CFM)						
	Screw Compressors					Reciprocating Compressors	
	Turbine Oil	Synthetic Oil	Polyglycol	PAO	Ester	Turbine Oil	Diester
PS-7	60	60	60	60	60	60	60
PSG-15	290	215	175	290	215	145	123
PSG-30	575	430	390	575	430	288	244
PSG-60	1,150	860	750	1,150	860	575	489
PSG-90	1,725	1,300	950	1,725	1,300	863	733
PSGK-120	2,300	1,725	1,500	2,300	1,725	1,150	978
PSGK-180	3,450	2,600	1,900	3,450	2,600	1,725	1,466

- NOTES: 1. Ratings are based on 4 PPM oil carryover
 2. Filter life is one (1) year based on 4,000 operating hours per year.

7.0 TROUBLESHOOTING

Trouble	Probable Cause/Remedy
Water in Oil Container	<p>Unit is not on a level surface.</p> <ul style="list-style-type: none"> • Level area as noted in “PLACEMENT” section. <p>Oil Outlet Tube is set too low allowing water to exit with the oil.</p> <ul style="list-style-type: none"> • Refer to “OIL OUTLET TUBE ADJUSTMENT” section for details. <p>A large condensate surge will elevate the water level above the Oil Outlet Tube and allow water to escape before level adjusts.</p> <ul style="list-style-type: none"> • Install a Flow Divider (CCN 2204432) to prevent an overload by controlling the surge. • Install the proper demand drain to prevent surge, reduce emulsification, and extend filter life. Contact IR for assistance.
Condensate spills out at base of Inlet Diffuser Assembly	<p>Large condensate surges can exceed the capacity of the Sediment Chamber and cause it to overflow below the Inlet Diffuser Assembly.</p> <ul style="list-style-type: none"> • Install a Flow Divider (CCN 2204432) to prevent an overload by controlling the surge. • Install the proper demand drain to prevent surge, reduce emulsification, and extend filter life. Contact IR for assistance.
Condensate backs up inside Diffuser Assembly	<p>Flow through Separation Filter is restricted by sludge or debris.</p> <ul style="list-style-type: none"> • Replace Separation Filter. See “SEPARATION FILTER” replacement instructions located in “MAINTENANCE INSTRUCTIONS”
Oil layer is lumpy and foamy	<p>Bacterial contamination.</p> <ul style="list-style-type: none"> • Disassemble the separator. Pressure wash or steam clean vessel and components. Rinse well and replace filters and modules.
No oil in Oil Container	<p>Oil accumulation will vary and may take months to establish a layer.</p> <ul style="list-style-type: none"> • Check depth of oil layer in the vessel. Refer to the “OIL OUTLET TUBE ADJUSTMENT” section for details. • Oil Outlet Tube may be set too high.
Frequent Adsorption Module Replacement	<p>Lubricant has poor demulsibility characteristics and or unit is undersized.</p> <ul style="list-style-type: none"> • Perform the “GLASS JAR TEST” as described in the INTRODUCTION. Contact IR for further assistance. • Replace lubricant with another that has better demulsification characteristics to extend the Adsorption Module life. • Replace timer-style drains with demand drains to reduce emulsification. Contact IR for assistance. <p>Turbulence due to large condensate surges allows emulsified oil to enter Adsorption Module.</p> <ul style="list-style-type: none"> • Install a Flow Divider (CCN 2204432) to prevent turbulence by controlling surges. <p>Atmospheric contaminants are creating irreversible emulsion.</p> <ul style="list-style-type: none"> • Determine source of contaminant and isolate from air intake. • Disassemble and pressure wash or steam clean separator and components. Rinse well and reassemble with new filters and modules. <p>Different lubricants from multiple sources limits demulsification.</p> <ul style="list-style-type: none"> • Standardize on a lubricant on multiple compressor systems. • Isolate different lubricant systems and install parallel systems. <p>Cross-contamination of lubricants.</p> <ul style="list-style-type: none"> • Use a dedicated transfer device for each lubricant and clean after use.

8.0 GENERAL DATA

Model PSG	A	B	C	D	E	F	G	J	K	L	M	N	P	Q	R
15	29.7	27.0	20.7	14.5	11.3	5.3	16.0	26.5	26.0	9.0	14.0	19.5	4.5	2.7	10.7
30	39.0	36.3	20.7	14.5	11.3	5.3	16.0	26.5	26.0	9.0	14.0	19.5	4.5	2.7	10.7
60	39.0	36.3	30.0	20.2	17.1	4.7	23.0	35.0	32.0	21.8	26.8	31.5	6.0	6.9	18.0
90	45.0	41.3	36.0	26.0	23.1	4.7	29.0	35.0	32.0	21.8	26.8	31.5	6.0	16.9	18.0

NOTES: 1. ALL DIMENSIONS IN INCHES, UNLESS OTHERWISE SHOWN.
 2. ALL DIMENSIONS ARE +/- .5, UNLESS OTHERWISE SHOWN.
 3. DIFFUSER IS ROTATABLE IN 90° INCREMENTS.
 4. PSG-60 USED TO ILLUSTRATE DIMENSIONS.

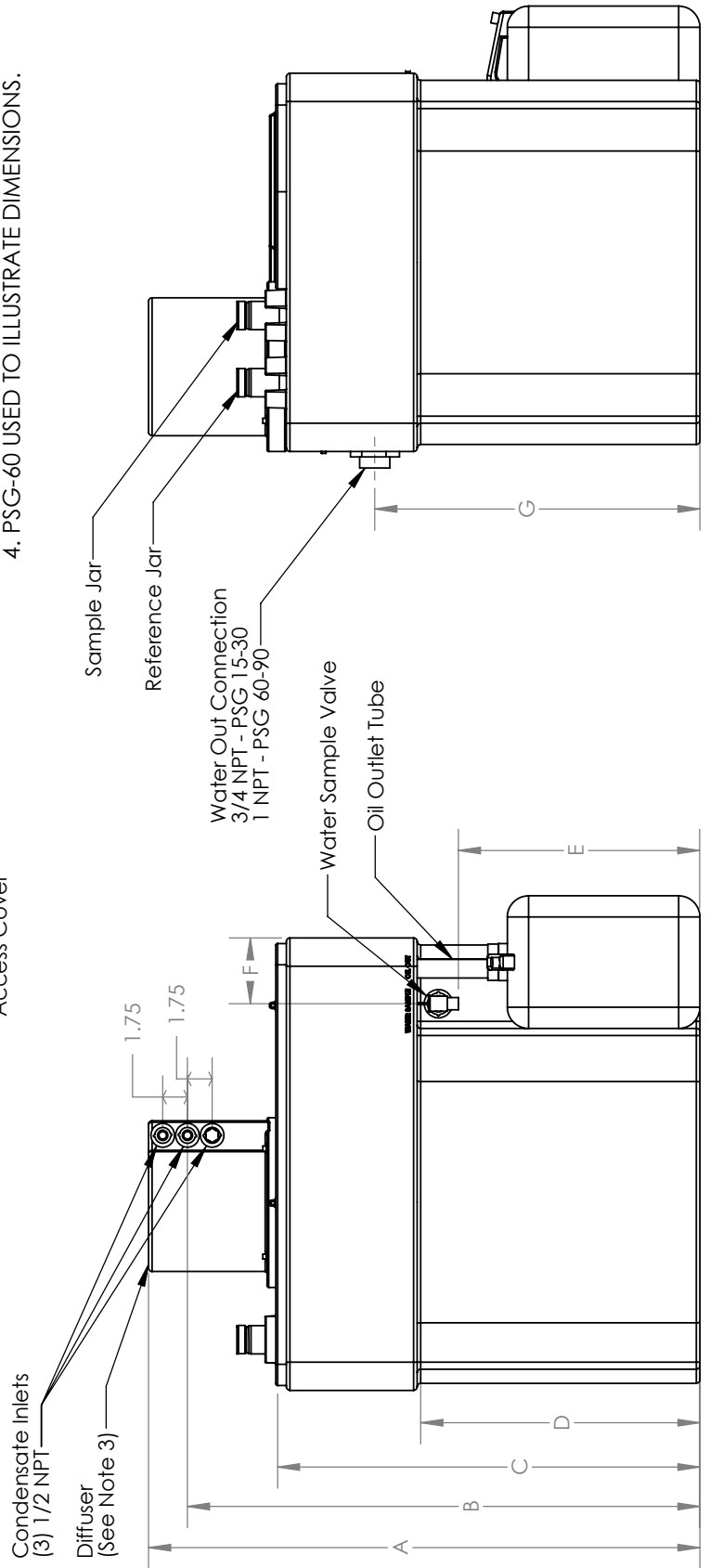
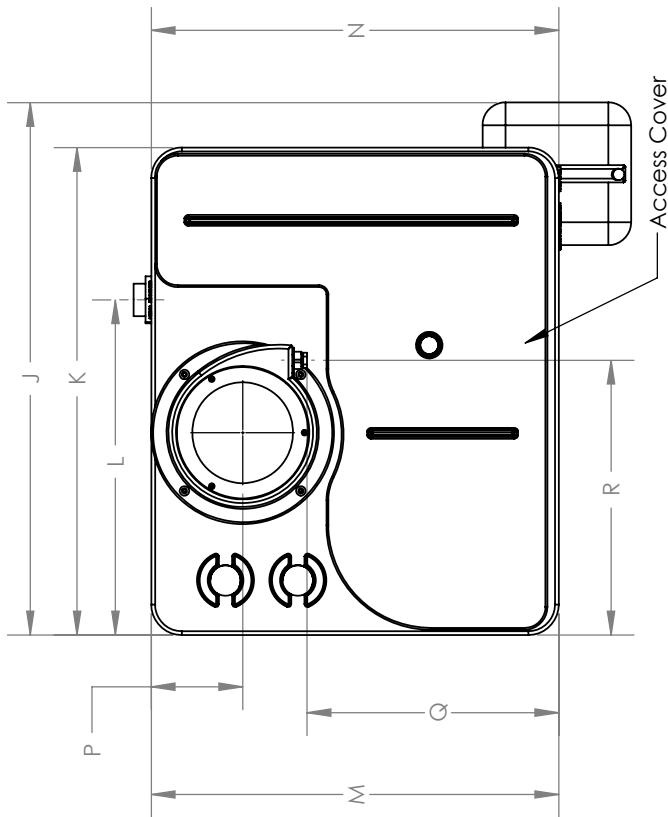

9.0 PARTS

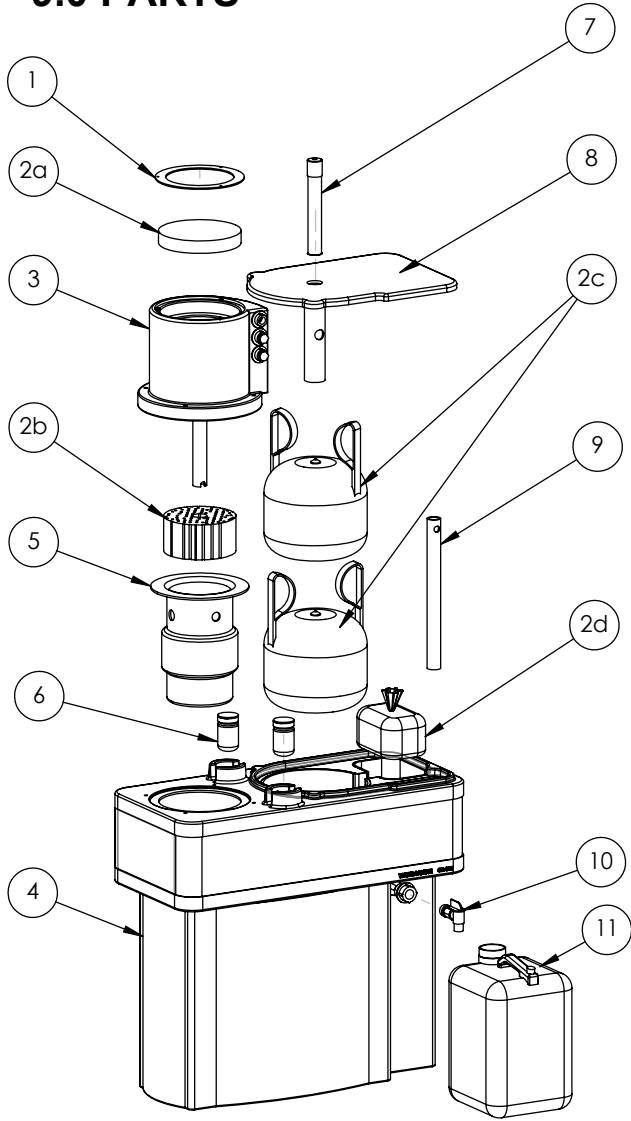

PSG-15/30

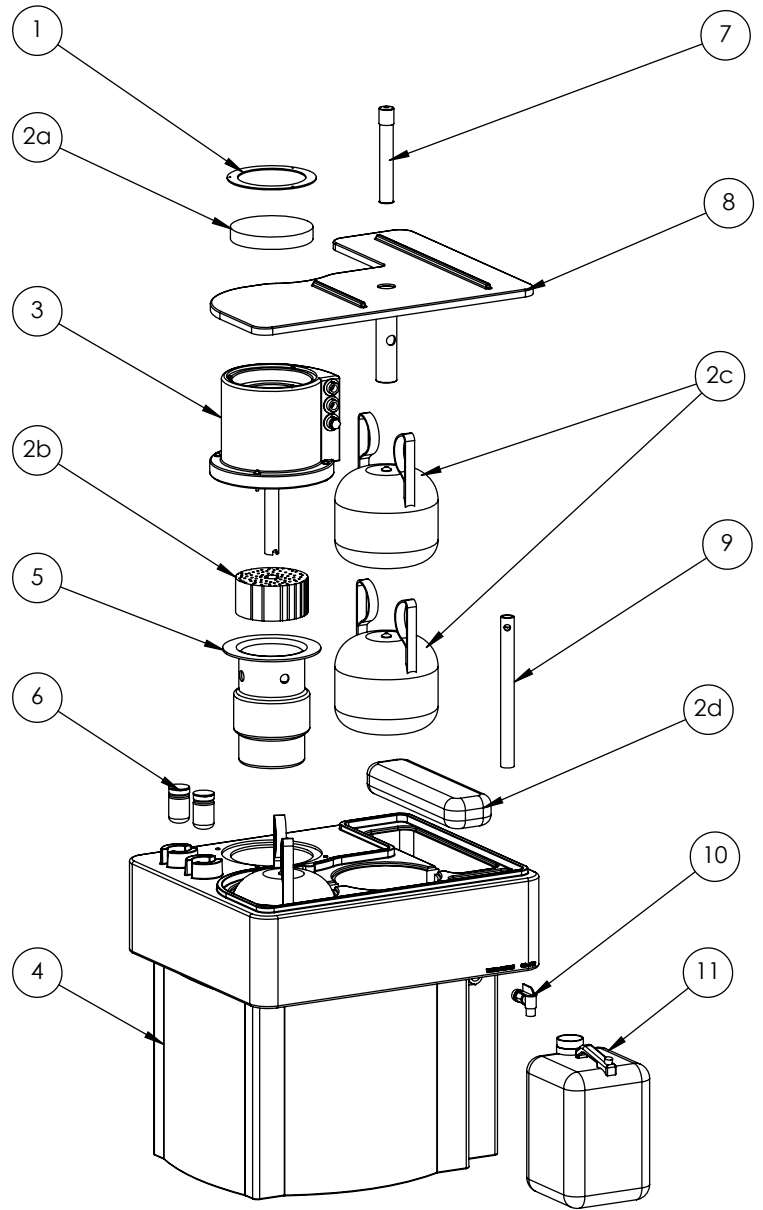

PSG-60/90

PSG PARTS TABLE

Part	Description	PSG-15	Qty	PSG-30	Qty	PSG-60	Qty	PSG-90	Qty
1	Diffuser Cover Ring	38339875	1	38465662	1	38465662	1	38465662	1
2a	Diffuser Pad	38339057	1	38465712	1	38465761	1	38469052	1
2b	Separation Filter		1		1		1		1
2c	Adsorption Module		1		2		4		4
2d	Pre-Adsorption Pad		1		1		1		1
3	Diffuser Assembly	38339891	1	38465670	1	38465670	1	38465670	1
4	Vessel	38339966	1	38465720	1	38465753	1	38465688	1
5	Sediment Chamber	38339917	1	38465696	1	38465696	1	38465696	1
6	Sample Jar	38339925	2	38339925	2	38339925	2	38339925	2
7	Flow Indicator	38339933	1	38469532	1	38469532	1	38469532	1
8	Cover	38339941	1	38465704	1	38465746	1	38465746	1
9	Oil Outlet Tube	38339958	1	38469540	1	38469540	1	38469540	1
10	Sample Valve	38339974	1	38339974	1	38339974	1	38339974	1
11	Oil Container	38339982	1	38339982	1	38339982	1	38339982	1