

# INSTRUCTION MANUAL

## HES Series with ColdWave™ Technology

Models: HES 800, 1000, 1250, 1500, 1750,  
2000, 2500, 3000



AN SPX BRAND

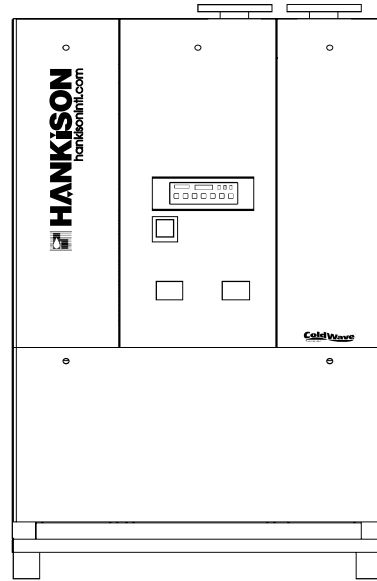

### CONTENTS

- GENERAL SAFETY INFORMATION.....2
- RECEIVING, MOVING, AND UNPACKING.....2
- 1.0 INSTALLATION .....3
- 2.0 OPERATION .....5
- 3.0 MAINTENANCE.....10
- SIZING.....11
- ELECTRICAL SCHEMATICS
  - Model 800 .....12,13
  - Models 1000 and 1250.....14,15
  - Models 1500 and 1750.....16,17
  - Models 2000 and 2500.....18,19
  - Model 3000 .....20,21
- DIMENSIONS / WEIGHTS .....22
- ENGINEERING DATA .....23,24
- TROUBLESHOOTING GUIDE.....25
- PARTS LIST .....26
- WARRANTY .....28

## REFRIGERATED

---

## TYPE

---

## COMPRESSED

---

## AIR DRYERS

---

## GENERAL SAFETY INFORMATION

### 1. PRESSURIZED DEVICES:

This equipment is a pressure containing device.

- Do not exceed maximum operating pressure as shown on equipment serial number tag.
- Make sure equipment is depressurized before working on or disassembling it for service.

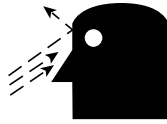

### 2. ELECTRICAL:

This equipment requires electricity to operate.

- Install equipment in compliance with all applicable electrical codes.
- Standard equipment is supplied with electrical enclosures not intended for installation in hazardous environments.
- Disconnect power supply to equipment when performing any electrical service work.

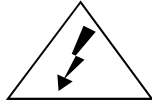

### 3. BREATHING AIR:

- Air treated by this equipment may not be suitable for breathing without further purification.

Refer to applicable standards and specifications for the requirements for breathing quality air.

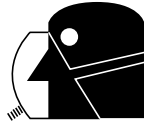

## RECEIVING, MOVING, AND UNPACKING

### A. RECEIVING

This shipment has been thoroughly checked, packed and inspected before leaving our plant. It was received in good condition by the carrier and was so acknowledged.

Check for Visible Loss or Damage. If this shipment shows evidence of loss or damage at time of delivery to you, insist that a notation of this loss or damage be made on the delivery receipt by the carrier's agent.

### B. UNPACKING

Check for Concealed Loss or Damage. When a shipment has been delivered to you in apparent good order, but concealed damage is found upon unpacking, notify the carrier immediately and insist on his agent inspecting the shipment. Concealed damage claims are not our responsibility as our terms are F.O.B. point of shipment.

### C. MOVING

In moving or transporting dryer, do not tip dryer onto its side.

### D. STORAGE/SHUT DOWN

**CAUTION** Dryer should not be stored outside (either packed or unpacked) or exposed to the weather. Damage to electrical and control components may result.

**IMPORTANT: WATER-COOLED UNITS** - If unit is shut down in below freezing temperatures, the water-cooled condenser may freeze and cause permanent damage. Condenser must be drained when the unit is shut down.

**IMPORTANT:** Do not store dryer in temperatures above 130°F (54°C).

IMPORTANT: READ PRIOR TO STARTING THIS EQUIPMENT

## 1.0 INSTALLATION

### 1.1 Location

- A. For typical placement in a compressed air system, see drawing.
- B. Air compressor intake – Locate air compressor so that contaminants potentially harmful to the dryer (e.g. ammonia) are not drawn into the air system.
- C. Dryer should be installed in a moderately heated, well ventilated area. Avoid locations immediately adjacent to cold exterior windows or walls, or adjacent to high temperature ovens or boilers.
- D. Clearances: Free air flow
  - Front 37.3/8 inches (950 mm)
  - Back 37.3/8 inches (950 mm)
  - Left Side 37.3/8 inches (950 mm)
  - Right Side 6 inches (153 mm)
  - Top 25.5/8 inches (650 mm)
 Service - To facilitate maintenance leave 37.3/8 inches (950 mm) of clearance in front of dryer.
- E. Standard units are designed to operate in ambients:
  - Air-cooled: 40 to 110°F (4 to 43°C).
  - Water-cooled: 40 to 130°F (4 to 54°C).
- F. Dryer is designed to operate at all altitudes - no adjustment for altitude is required.
- G. The installation of a flexible connection prior to the dryer is recommended to prevent possible damage from vibration.

NOTE: Outdoor installation – Standard units are designed for indoor installation. Contact manufacturer if installing outdoors.

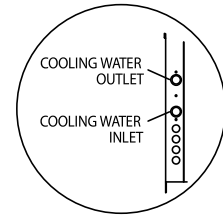
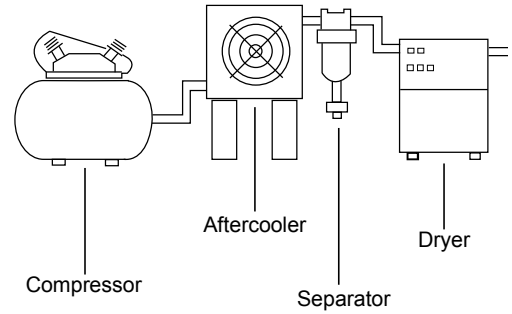

**DETAIL 'A'**  
Cooling Water Connection Ports for  
Models 800, 1000, 1250, 1500

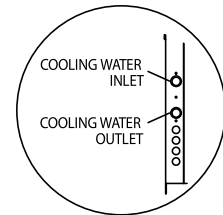

**DETAIL 'B'**  
Cooling Water Connection Ports for  
Models 1750, 2000, 2500, 3000

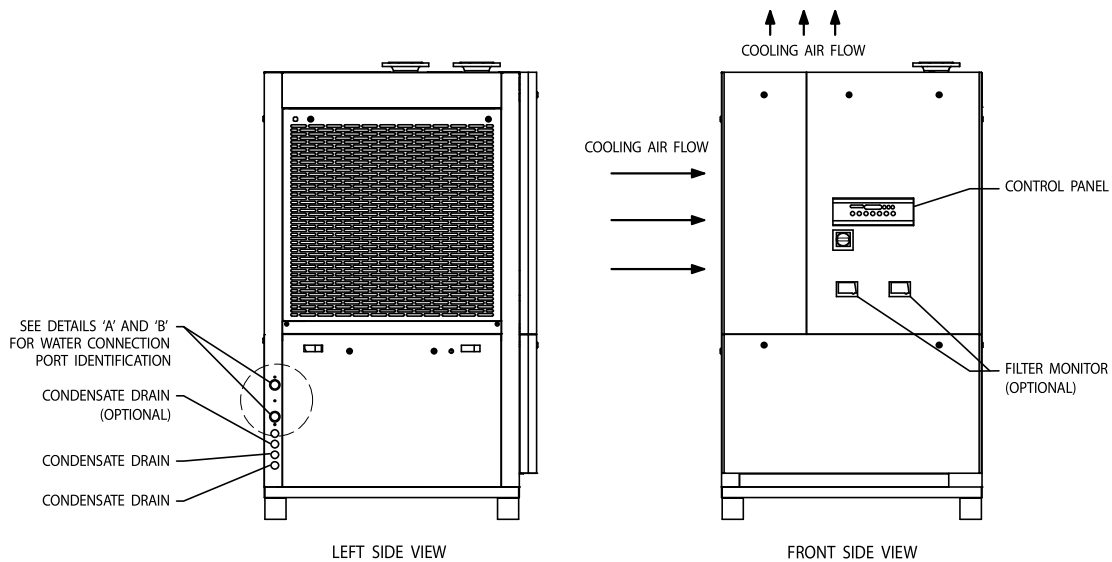

## 1.2 Mounting

Mount the dryer on a level solid surface. Holes are provided in the dryer base to permanently mount the dryer to the floor.

## 1.3 Piping Connections

- A. Air Inlet - Connect compressed air line from air source to air inlet.

**⚠ WARNING** Refer to Serial Number Tag for maximum working pressure. Do not exceed dryer's Maximum Working Pressure.

NOTE: Install dryer in air system at highest pressure possible (e.g. before pressure reducing valves).

NOTE: Install dryer at coolest compressed air temperature possible. Maximum inlet compressed air temperature: 120°F (49°C). If inlet air exceeds this temperature, precool the air with an aftercooler.

- B. Air Outlet - Connect air outlet to downstream air lines.
- C. Bypass piping - If servicing the dryer without interrupting the air supply is desired, piping should include inlet and outlet valves and an air bypass valve.
- D. Water-cooled models - cooling water inlet and outlet
1. Connect cooling water supply to cooling water inlet.
  2. Connect cooling water return line to cooling water outlet connection.

NOTE: Strainer and water regulating valve are supplied on water-cooled models. Also, it is recommended to add water inlet/outlet temperature and pressure gauges to the water piping.

## 1.4 Electrical Connections

IMPORTANT: Use copper supply wires only.

- A. Dryer is designed to operate on the voltage, phase, and frequency listed on the serial number tag.
- B. Electrical entry is through a hole in the top of the cabinet. Route wires through the bottom of the electrical enclosure. Connect power source to the terminal strip in the electrical enclosure as shown on the electrical schematic included with the dryer.

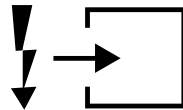

NOTE: Refrigeration condensing unit is designed to run continuously and should **NOT** be wired to cycle on/off with the air compressor.

## 1.5 Electronic Demand Drain

- A. An automatic electric demand drain (EDD) discharges condensate removed by the separator.
- B. All dryer models are supplied with one EDD. Models with the additional (optional) oil removal filter are supplied with a second EDD.
- C. The drains are piped to fittings in the leg of the unit. Condensate should be piped from this fitting to an open vented floor drain or sump.

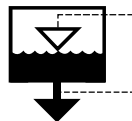

NOTE: Discharge is at system pressure. Drain line should be anchored.

NOTE: Condensate may contain oil. Comply with applicable laws concerning proper disposal.

- D. Verify that isolation valves are open. If the drain fails to discharge after the valve is energized, the electronic control circuit will repeatedly energize the valve in an attempt to clear the discharge port. If, after 60 seconds, the drain still fails to discharge, the control circuit then switches to the alarm mode. In this mode the valve is de-energized and the red alarm light is activated on the drain and the dryer controller. The valve is then automatically energized every 4 minutes for 5 seconds. Check the drain operation. Push drain (push-to-test) button on the Energy Management Monitor control board to energize drain. A flow of condensate and/or air should be present at the drain outlet. The alarm mode automatically clears after the drain returns to normal operation.
- E. **Description of Operation:** Condensate enters the reservoir (1) through the inlet port. When the condensate level in the reservoir covers the capacitance sensor, an electronic signal is sent to the solid state countdown processor. The processor delays the opening of the solenoid valve for a given period of time. Once the time has elapsed, the solid state processor transmits information to energize the coil in the solenoid valve (2). The magnetic force of the coil causes the solenoid core (3) to move, closing the pilot air supply line and opening the pilot air exhaust line. After the pilot air above the diaphragm (4) is vented, pressure in the reservoir opens the discharge port and forces the condensate through the discharge port and outlet piping.

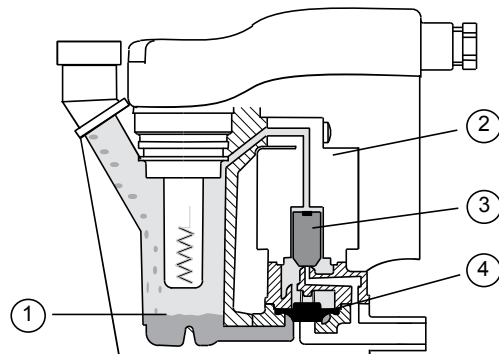

## 2.0 OPERATION

Basic theory of operation: This energy saving dryer has a completely new compressor technology at the heart of its operation. This is the Digital Scroll. This compressor has a unique mechanism that allows it to be completely “unloaded”. This is accomplished internally, using a piston to “pull” the upper scroll apart from the lower scroll. This stops the compression of the refrigerant. At the same time: the electric motor unloads and continues to turn, providing lubrication to the mechanism. This greatly reduces power consumption from the loaded state. At 100% load the compressor runs fully loaded, with no noticeable difference between this compressor at full load and the standard scroll compressor. The solenoid controlling the loading and unloading cycles open and closed in response to the temperature of the refrigerant and thereby the load on the system.

NOTE: The compressor sound changes noticeably between the loaded and unloaded state, this occurs every ten to twenty seconds.

### 2.1 Minimum/Maximum Operating Conditions

- A. Maximum inlet air pressure: refer to dryer serial number tag
- B. Minimum inlet air pressure: 30 psig (2.1 barg)
- C. Maximum inlet air temperature: 120°F (49°C)
- D. Maximum ambient temperature:  
Air-cooled models: 110°F (43°C)  
Water-cooled models: 130°F (54°C)
- E. Minimum ambient temperature: 40°F (4°C)

### 2.2 Start-up

- A. Energize dryer. Green power on light will illuminate.

**IMPORTANT:** Energize dryer for 24 hours before refrigeration compressor is started! Never use the disconnect switch to shutdown the dryer for an extended period of time (except for repair). Failure to follow these instructions may result in a non-warrantable compressor failure.

### B. Program Monitor

Press and hold Program Mode button until Main Menu screen appears. Use the Up and Down arrow buttons to scroll through the list of sub-menu choices. Press Enter button to view the sub-menu that is displayed. Press ESC to exit the Main Menu and return to Display mode.

1. Language Selection
  - a. Use the ‘Up’ and ‘Down’ arrow buttons to scroll through the list of languages (choice of 10 available: English, Deutsch, Francais, Espanol, Italiano, Polski, Dansk, Dutch, Norsk and Suomi).
  - b. Press ‘Enter’ button to select the language that is displayed.
  - c. Push ‘ESC’ at any time to return to the Main Menu.

### CONTROL PANEL

1. Temperature Indicator
2. Operator Interface Display
3. Power-on Light
4. Compressor-on Light
5. Alarm / Service Light
6. Schedule On/Off and Enter Button
  - a. In display mode: Press to toggle between SCHEDULE RUNNING and MANUAL OVERRIDE.
  - b. In program mode:
    - i. Press to move to a lower level menu.
    - ii. Press to accept a value that has been edited.
7. Program Mode (i) and Esc
  - a. In display mode: Press and hold to enter program mode.
  - b. In program mode: Press to move to a higher level menu.
8. Up Arrow
  - a. In display mode: No function
  - b. In program mode:
    - i. Press to view the next item in a list or to increment a variable to a higher value. Press and hold for accelerated incrementing.
    - ii. When the top of the list (or highest value) is displayed, pressing the up button will cause the display to wrap to the bottom of the list (or lowest value).
9. Down Arrow
  - a. In display mode: No function
  - b. In program mode:
    - i. Press to view the previous item in a list or to increment a variable to a lower value. Press and hold for accelerated incrementing.
    - ii. When the bottom of the list (or lowest value) is displayed, pressing the down button will cause the display to wrap to the top of the list (or highest value).
10. 1/0: Press at any time to turn the dryer on/off.
11. Drain test: Press at any time to momentarily open the drains.
12. Reset: Press at any time to clear the alarm/service message (if shown) and the alarm LED.

## 2. Setting Date & Time

- a. Use the 'Up' and 'Down' arrow buttons to set minutes (00 to 59). Press 'Enter' to accept new value.
- b. Use the 'Up' and 'Down' arrow buttons to set hours (00 to 23). Press 'Enter' to accept new value.
- c. Use the 'Up' and 'Down' arrow buttons to set year (00 to 99 representing 2000 to 2099). Press 'Enter' to accept new value.
- d. Use the 'Up' and 'Down' arrow buttons to set month (three letter abbreviation). Press 'Enter' to accept new value.
- e. Use the 'Up' and 'Down' arrow buttons to set day (01 to maximum for the month and year selected). Press 'Enter' to accept new value.
- f. Push 'ESC' at any time to return to the Main Menu.

## 3. Setting Schedule

- a. Use the 'Up' and 'Down' arrow buttons to select desired "Day of week + on/off". Press 'Enter' to accept new value.
- b. Use the 'Up' and 'Down' arrow buttons to set hour (00 to 23). Press 'Enter' to accept new value.  
Note: If the hour setting is 'IGNORE', Press 'Enter' again to move the cursor under the "Day of week + on/off".
- c. Use the 'Up' and 'Down' arrow buttons to set minutes (00, 10, 20, 30, 40, 50; not shown if hour setting is 'IGNORE'). Press 'Enter' to accept new value and return to "Day of week + on/off". Repeat steps a through c as needed.
- d. Push 'ESC' at any time to return to the Main Menu.

## 4. Hours To Service

- a. Use the 'Up' and 'Down' arrow buttons to scroll through the range of permissible values (0 to 8760) before service reminder is initiated. Press 'Enter' to accept new value. (Only hours that refrigeration compressor is operating are counted).
- b. Press 'ESC' at any time to return to the Main Menu.

NOTE: On dryers with air-cooled condensers, regular condenser cleaning is recommended. Dirtiness of ambient air at installation site will determine frequency of service. Typically once a month is recommended.

NOTE: All dryers contain an integral 3 micron filter. As the filter element accumulates solid contaminants, differential pressure increases. Solid particulate load in the compressed air supply will determine frequency of service. Typically element changeout is recommended at least annually.

## 5. Alarm History

- a. Use the 'Up' and 'Down' arrow buttons to scroll through the last twenty (20) alarms beginning with the most recent alarm.  
NOTE: The number at the end of the top line with a cursor underneath identifies which of the past twenty alarms is being displayed.
- b. Press 'ESC' at any time to return to the Main Menu.

- c. To clear the alarm history, press and hold the 'Enter' button then press the 'Up' arrow button. Release both buttons.

## 6. Energy Cost

- a. Use the 'Up' and 'Down' arrow buttons to select the desired currency (\$ or €). Press 'Enter' to accept new value.
- b. Use the 'Up' and 'Down' arrow buttons to set the energy cost. Press 'Enter' to accept new value.
- c. Press 'ESC' at any time to return to the Main Menu.

## 7. Push ESC button to exit program mode.

NOTE: If after 60 seconds no button is pressed while in Program Mode, the audible alarm sounds for five (5) seconds and the controller exits program mode. Dryer will resume previous operating mode.

## C. Starting Dryer

**IMPORTANT:** Dryer must be energized 24 hours before starting refrigeration compressor.

NOTE: It is recommended that dryer be started 15 minutes before compressed air flow begins.

1. On water-cooled models: after 24 hours and before starting dryer, begin cooling water flow.
2. Check for proper electrical voltage.
3. Slowly pressurize unit air side by opening inlet isolation valve. Check for leaks.
4. After 15 minutes, open outlet isolation valve slowly.
5. Close air bypass valve.
6. Dryer may be operated in Manual or scheduled modes.

NOTE: Check for correct phasing of unit. On air-cooled models: check fan rotation (air must be pulled through the condenser). Fans may not start immediately or may cycle on and off. If rotation is in the wrong direction follow the procedure below. On water-cooled models: After starting dryer, if an unusual noise is heard and the discharge line does not get hot, stop the dryer, reverse two power leads, restart, and verify discharge line gets hot.

- a. Manual mode - push 'On/Off' button - refrigeration compressor will start and run, green Compressor-on light will illuminate. In this mode compressor will run continuously and will not be turned on and off by the monitor. MANUAL OVERRIDE will appear on interface panel.
- b. Schedule mode - push 'Schedule On/Off and Enter' button. SCHEDULE RUNNING will appear on the interface panel. The refrigeration compressor will continue to be on or off (as selected in the Manual Override Mode) until the next scheduled event. The compressor will then turn on or off as programmed.

NOTE: Dryer may be returned to the manual mode at any time using the 'Schedule On/Off and Enter' button. MANUAL OVERRIDE will appear on interface panel. To reinstitute Schedule, push the 'Schedule On/Off and Enter' button again.

NOTE: Restart after the power interruption. Unit will be in MANUAL OVERRIDE mode, refrigeration compressor, off when power is restored after power interruption.

7. To reinstitute SCHEDULE RUNNING: push 'Schedule On/Off and Enter' button.

IMPORTANT: Dryer must be energized 24 hours before refrigeration compressor is started.

#### D. Operating Check Points

1. Check that green Power-on light is illuminated.
2. Check that green Compressor-on light is illuminated if dryer is on in the manual mode or it is a scheduled on time.

IMPORTANT: Refrigeration compressor must be restarted after power interruption.

3. Check interface panel.

NOTE: Interface panel will scroll through three screens (Current Time/Operating Status, Hours to Service, and Total Operating Hours).

- a. Verify that current time is correct.
- b. Check HRS TO SERVICE: this indicates time remaining until service is required; allow time for required maintenance items to be ordered.
- c. Check operating status:
 

MANUAL OVERRIDE - Dryer is either running continuously (not being controlled by the scheduled on/off times) or the refrigeration compressor has been shut off using the 'On/Off' button.

SCHEDULE RUNNING - Refrigeration compressor is being turned on and off by the monitor per-programmed schedule (see B.3. to set schedule).
- d. Check Temperature indicator - indicator should read in the green area.
- e. Check Alarm/Service light. If illuminated, check Interface panel.
  - 1) If SERVICE DRYER appears, scheduled maintenance time has elapsed (HRS TO SERVICE is 0). Perform needed service and reset service interval (see B.4.).
  - 2) If ALARM appears, a dryer fault is indicated; see Troubleshooting Guide for possible remedies. After fault correction push Reset button to turn Fault alarm off.
 

Type of FAULTS:

HIGH DISCHARGE TEMPERATURE - refrigerant discharge temperature is above the set point.

LOW PRESSURE - the refrigeration compressor control circuit has opened because of low suction pressure.

HIGH PRESSURE - the refrigeration compressor control circuit has opened because of high head pressure. The high pressure switch must be reset manually once the fault is corrected. Red reset button is located on pressure switch inside unit.

HIGH EVAPORATOR TEMPERATURE - compressed air temperature is above the set point.

COMPRESSOR - normally open (NO) auxiliary contact on the compressor contactor is open when the dryer is on.

HEATER - normally closed (NC) auxiliary contact on the compressor contactor is open when the dryer is off.

TEMP SENSOR - occurs if the temperature sensor circuit is open or shorted. If open, the left-most LED in the temperature display will be illuminated. If shorted, all the LEDs in the temperature display will be illuminated.

DRAIN - electric drain contains a high water level alarm that activates if drain fails to discharge.

- f. Check drain operation - push Drain (push-to-test) button to energize electric drain. A flow of condensate and/or air should be present at the drain outlet.

#### E. Using the RS-232 Port

The RS-232 port is used to monitor dryer operation from a host computer. A (1 to 1) DB-9 cable is required to connect dryer and computer. For PC connections, data is transmitted on pin 2, received on pin 3, ground is pin 5, pins 7 and 8 are jumpered at dryer.

Operation is at fixed baud rate of 9,600; asynchronous format is 8 bit, no parity, 1 stop bit ("8,N,1"). No check sum or error correction values are provided. If required, request status string two (or more) times and compare for agreement.

Request data by sending ASCII ? character (3FH). Response may take up to two seconds as certain processing functions may require completion before serial port is acknowledged.

Dryer responds with line feed (0AH), carriage return (0DH), and character string: (1), (2), (3), (4), (5), (6), (7)

- (1) = STX (start-of-text character, may appear as a smiley face or some other character)
- (2) = 17, Control board ID
- (3) = 0 or 1, Compressor running status (0=off, 1=on)
- (4) = M or S, Operating Mode (M= MANUAL OVERRIDE, S = SCHEDULE RUNNING)
- (5) = xxxx, HOURS TO SERVICE
- (6) = xx, Alarm or Service Code
  - 0 = no alarm,
  - 29 = HIGH DISCHARGE TEMP ALARM,
  - 30 = LOW PRESSURE ALARM,
  - 31 = HIGH PRESSURE ALARM,
  - 32 = COMPRESSOR ALARM,
  - 36 = HIGH EVAP TEMP ALARM,
  - 37 = HEATER ALARM,
  - 38 = DRAIN ALARM,
  - 39 = SERVICE DRYER,
  - 41 = TEMP SENSOR ALARM)
- (7) = ETX, (end-of-text character, may appear as a heart or some other character)

### 2.3 Filter Monitor (optional)

The Filter Monitor continuously monitors the differential pressure (pressure drop) across the standard Grade 9 element in the moisture separator. Models with the optional Grade 5 Oil Removal Filters include a dedicated Filter monitor as well to alert the operator of the need for element replacement when any of three operating criteria are met:

1. Maximum elapsed time (service interval) before change-out - operator alerted when user selected time period elapses.
2. Maximum allowable differential pressure - operator alerted when user selected maximum differential pressure occurs.
3. Intelligence - operator alerted when the optimum time to replace the element(s) has occurred. The Monitor calculates this using the element type, the initial characteristic pressure drop and historical pressure drop data.

#### Recommended Settings for Integral Filtration

1. Maximum time before element replacement:
2. Maximum pressure differential:

**Table 1**

Model Number	Standard Grade 9 Moisture Separator Pressure Drop Setting				Element Setting	Optional Grade 5 Oil Removal Filter Pressure Drop Setting			Element Setting	Service Interval
	psig	kgf/cm <sup>2</sup>	bar	Letter Type		psig	kgf/cm <sup>2</sup>	bar		
800	1.00	0.07	0.07	B	4.5	0.39	0.38	E	As indicated by Filter Monitor Display, or Annually	
1000	1.00	0.07	0.07	B	5.5	0.39	0.38	E		
1250	1.50	0.11	0.10	B	6.5	0.46	0.45	E		
1500	2.00	0.14	0.14	B	8	0.56	0.55	E		
1750	1.00	0.07	0.07	B	4.5	0.32	0.31	E		
2000	1.00	0.07	0.07	B	5.5	0.39	0.38	E		
2500	1.50	0.11	0.10	B	6.5	0.46	0.45	E		
3000	2.00	0.14	0.14	B	8	0.56	0.55	E		

#### Programming Instructions

(Short version - for complete instructions see page 9)

1. To begin programming, press and hold ENTER button for 3 seconds.
2. Press and hold the scroll button to input maximum service interval (1 to 15 months) - press ENTER.
3. Press and hold the scroll button to select pressure unit of measure (KG/CM<sup>2</sup>, PSI, or BAR). - press ENTER.
4. Press and hold the scroll button to input maximum pressure drop (0.01 to 1.00 KG/CM<sup>2</sup> or BAR; 0.1 to 15 PSI) Use Left Shift and Right Shift buttons to select advance rate (e.g. by ones, tenths, or hundredths) -press ENTER.
5. Press and hold the scroll button to select the element letter type (see chart above) - press ENTER.
6. Select Initialize or Run mode.  
 Initialize - Scroll until initial pressure drop and run icons are displayed. (To be selected during initial installation and element charge out).  
 Run -Scroll until run icon only is displayed. (To be selected if Monitor is reprogrammed without changing the element).
7. Press ENTER to start program.

### 2.4 Display Legend

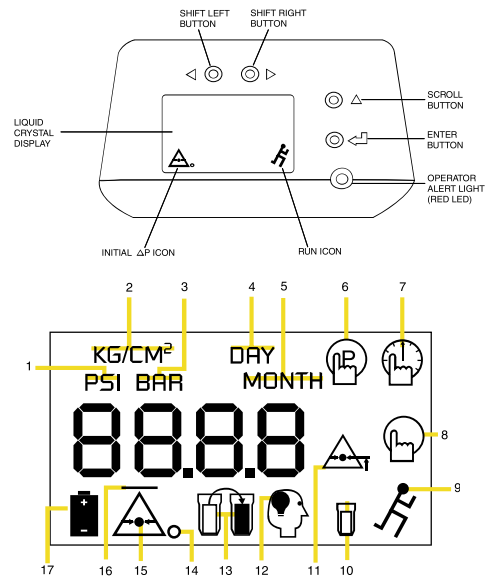

#### LED DISPLAY

1. Unit of measure selection - pressure - pounds per square inch.
2. Unit of measure selection - pressure - kilograms per square centimeter.
3. Unit of measure selection - pressure - bar.
4. Indicates that predicted number of days until element replacement required is being displayed or with 13 to indicate element replacement required because maximum time has elapsed.
5. Displayed with 7 in program mode when inputting maximum time before element replacement.
6. Indicates Monitor is in program mode.
7. Displayed in program mode when inputting maximum time before element replacement.
8. Displayed in program mode with 10 when inputting element type.
9. Displayed alone when Run mode selected or with 14 and 15 when Initialize mode selected.
10. Displayed in program mode with 8 when inputting element type.
11. Displayed in program mode when inputting maximum differential pressure or with 13 to indicate element replacement required because maximum pressure differential has occurred.
12. Indicates Monitor is processing data. Or with 13 to indicate element replacement required due to intelligence.
13. Indicates need for element replacement.
14. Indicates (displayed with 15) that initial characteristic pressure drop is being displayed.
15. Indicates that current pressure drop is being displayed.
16. Indicates (displayed with 15) that average pressure drop is being displayed.
17. Indicates need for battery replacement.

## 2.5 Filter Monitor Power Supply

Each Filter Monitor receives transformed DC power from the control circuit through an RJ11 connection pin.

### A. Element Status Retention Batteries

Three batteries are pre-installed inside each Filter Monitor to retain element condition characteristics during power outages.

**Replacement** - Remove battery compartment cover and the three old batteries. Consult the compartment cover for proper orientation then, install three fresh AA, 1.5 V batteries. Re-install cover.

**Life** - Batteries perform a back-up function. A 15-24 month life cycle is anticipated. Replace batteries prior to their expiration during a planned filter element change to retain the element signature and ensure the maximum filter element life cycle.

**Memory** - Pre-programmed settings are retained during battery expiration and replacement. To keep the existing settings, the Filter Monitor will require initialization as described in section 3.3B. To change the programming, see section 2.3.

## 2.6 Programming

- After batteries are installed, red LED light will glow briefly; display will flash until unit is programmed.
- Press and hold Enter button for 3 seconds to begin programming.



- Select maximum elapsed time before element replacement - press Scroll button to advance from 1 to 15 months.
- Press Enter button to accept choice.



- Select unit of measure for pressure - use Scroll button to choose between KG/CM<sup>2</sup>, PSI, or BAR
- Press Enter button to accept choice.



- Select maximum allowable pressure drop - use Scroll button to advance from 0.01 to 1.00 KG/CM<sup>2</sup> or BAR; or 0.1 to 15 PSI. Use Shift buttons to change advance rate (BAR and KG/CM<sup>2</sup> - tenths or hundredths; PSI - tenths or ones).

- Press Enter button to accept choice.



- Input element type - use Scroll button to advance from "A" to "H". See chart on Page 1 for reference.

- Press Enter button to accept choice.



Select Initialize or Run modes.

## Initialize

Use Initialize on initial start-up or after replacing elements. See section 2.3 for programming instructions.

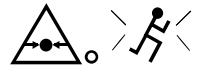

If Initialize is selected the program will ignore the first 24 hours of operation to allow the element(s) to achieve a steady state. After this period, pressure drop measurements will be averaged over the next 144 hours to determine an initial characteristic pressure drop. The differential pressure calculation used to determine the optimum time for element replacement uses this characteristic drop as the starting point. After the initialization period, Monitor automatically switches to the Run mode.

## Run

To select Run, press Scroll button so that only the run icon is displayed. If RUN is selected, the monitor uses the previous initial characteristic pressure drop as the reference. Use this mode if the Monitor is re-programmed but the element is not replaced.



- Press Enter button to exit program mode and begin operation.

## 2.7 Display

- Run mode - in the run mode, Processing icon flashes; indicating that the Monitor is processing data.



- Readouts - the display cycles through the following readouts:

- Current differential pressure.
- Average differential pressure over the past 24 hours.
- Projected days until element replacement. When the Monitor estimates that filter element replacement will occur within 60 days, the days remaining will be displayed. This allows time to have replacement element(s) on hand.



## 2.8 Alarms

- Indication of need for element replacement. If any criteria for element replacement is met, the red LED will flash.

- Need for replacement based on expiration of maximum time - "0 days" displayed



- Need for replacement based on maximum pressure drop - inputted maximum pressure drop displayed.



- Need for element replacement based on intelligence (calculated optimum time).



- Need for battery replacement - Battery Icon and red LED will flash.

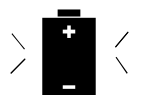

### 3.0 MAINTENANCE

#### 3.1 Monthly

- A. Air-Cooled: Clean refrigerant condenser. Blow the fins of the condenser clean with compressed air, if necessary, remove heavier soiling with a suitable cleansing agent.



- B. Water-cooled - clean strainer monthly, more often if required. Shut off water, remove small plug to relieve pressure, then remove large plug to remove strainer. Clean strainer and replace.
- C. Check the condensate drains by pressing the Drain Test button on the control panel (see page 5 for description and location). Visually check to assess whether condensate is separated and discharged.
- D. Check the dew point temperature on the control panel.
- E. Check the inlet compressed air temperature and the ambient temperature (or inlet cooling water temperature) to assure they are within the operational limits.

#### 3.2 Annual Maintenance

- A. Check all terminals in the switchgear cabinet and tighten them up if necessary.
- CAUTION** Check to be sure the unit is de-energized.
- B. Maintenance/Cleaning of the condensate drain.

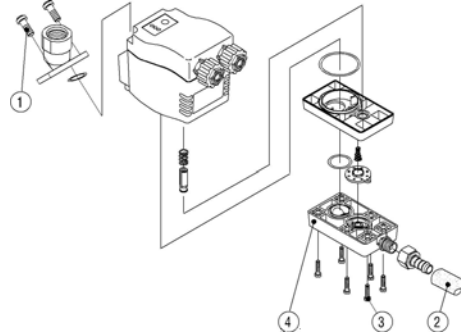

- CAUTION** Check to be sure the unit is depressurized and de-energized.

Maintenance recommendation:

1. Remove two pan head screws [1] and lift off condensate drain. The elbow adapter stays in place.
  2. Disconnect discharge hose [2].
  3. Turn the 6 pan head screws [3] until heads are level with the outer edge and take off diaphragm seat [4].
  4. Replace wearing parts. (All necessary service parts can be ordered in a service kit – See Parts List.)
  5. Reassemble condensate drain unit in reverse order.
- C. Replace the filter cartridges in the filter. (All necessary service parts can be ordered in a service kit – See Parts List.)
1. When to replace the Separator/Filters  
Replace filter element when pressure drop across dryer is excessive or annually.

Ref: 3.2, C., 2., e through h

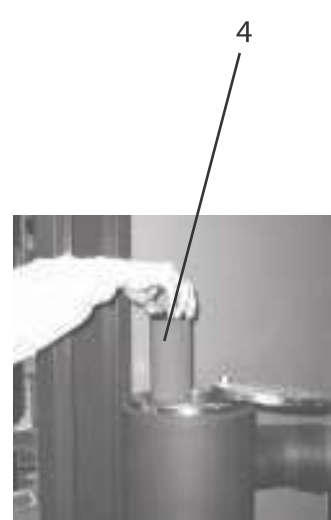
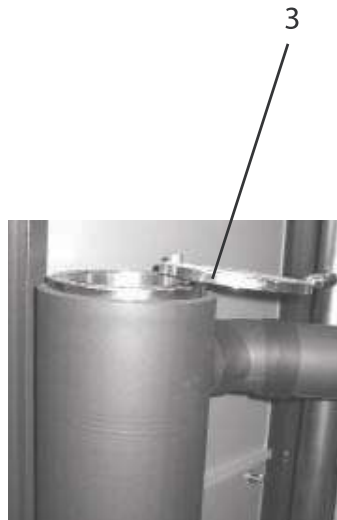

When removing liquids at rated flow conditions, the pressure drop will be 5 psi (0.35 bar), or less, across the entire dryer. An increase in pressure drop will occur only as the separator/filter elements become loaded with solid particles. It is recommended, for maximum filtration efficiency, the separator/filter elements be replaced when the pressure drop across the dryer exceeds 10 psi (0.7 bar), or every 12 months, whichever occurs first.

## 2. Replacement of the Separator/Filters

**▲ CAUTION** Depressurize the unit before servicing. Failure to do this may result in injury.

- a. Open the bypass between compressed air inlet and outlet. (if equipped)
- b. Close the shut-off devices at the compressed air inlet and outlet.
- c. Press the Drain Test button on the control panel (see page 5 for description and location) until the system is depressurized.
- d. Switch off the dryer.
- e. Remove the insulation [1].
- f. Loosen the screws [2] of the filter housing. Caution is necessary as the system may still be under slight residual pressure.
- g. Remove all screws except one and swing flange [3] to the side.
- h. Pull out the old cartridges [4].
- i. Push new cartridges on to the mounting posts in the bottom of the separator vessel.  
NOTE: Do not touch the foam sleeves of the cartridges with your fingers.
- j. Close housing in reverse order.
- k. Put on insulation.
- l. Switch on the dryer.
- m. Repressurize the dryer by slowly opening the compressed air inlet valve.
- n. Slowly open the compressed air outlet valve.
- o. Slowly close the compressed air bypass valve (if equipped).

### 3.3 Filter Monitor Programming (optional)

- A. Each Filter Monitor needs to be initialized whenever a new filter element is installed. Initialization resets the Intelligence circuitry to begin establishing a new performance baseline consistent with the unique signature of each individual element.
- B. To retain the existing settings previously established simply:
  1. Press and hold the “enter” button until the programming icon begins flashing.
  2. Slowly press and release the “enter” button five (5) times.
  3. Only the  will appear on the LCD display for the first 2 minutes of operation. Initialization is now complete.

## SIZING

Determining dryer capacity at actual operating conditions.

To determine the maximum inlet flow capacity of a dryer at various operating conditions, multiply the rated capacity from Table 1 by the multipliers shown in Table 2.

Example: How many scfm can a 60 Hz air-cooled model 1000 handle when compressed air to be dried is at 200 psig and 100°F; ambient air temperature is 80°F?

Answer: 1,000 x 1.22 x 1.12 = 1,366 scfm.

**TABLE 1**

Rated capacity (scfm) @ 100 psig inlet pressure, 100°F inlet temperature, and 100°F ambient temperature.

MODEL		800	1000	1250	1500	1750	2000	2500	3000
Rated capacity of air-cooled models (scfm)	60 Hz	800	1000	1250	1500	1750	2000	2500	3000
	50 Hz	672	830	1050	1250	1460	1670	2080	2500

**TABLE 2**

Air capacity correction factors (Multipliers)

INLET COMPRESSED AIR CONDITIONS						
INLET PRESSURES		INLET TEMPERATURES				
psig	barg	80°F	90°F	100°F	110°F	120°F
		27°C	32°C	38°C	43°C	49°C
50	3.4	1.35	1.05	0.84	0.69	0.56
80	5.5	1.50	1.17	0.95	0.79	0.66
100	6.9	1.55	1.23	1.00	0.82	0.70
125	8.6	1.63	1.31	1.07	0.91	0.74
150	10.3	1.70	1.37	1.13	0.95	0.80
175	12.1	1.75	1.42	1.18	0.99	0.84
200	13.8	1.80	1.47	1.22	1.03	0.89

COOLING MEDIUM*		
AMBIENT TEMPERATURE		MULTIPLIER
°F	°C	
80	27	1.12
90	32	1.06
100	38	1.00
110	43	0.94

\*Air-cooled models; water-cooled models use 1.15 multiplier if cooling water is below 95°F (35°C).

# ELECTRICAL SCHEMATICS

Model 800  
Sheet 1 of 2

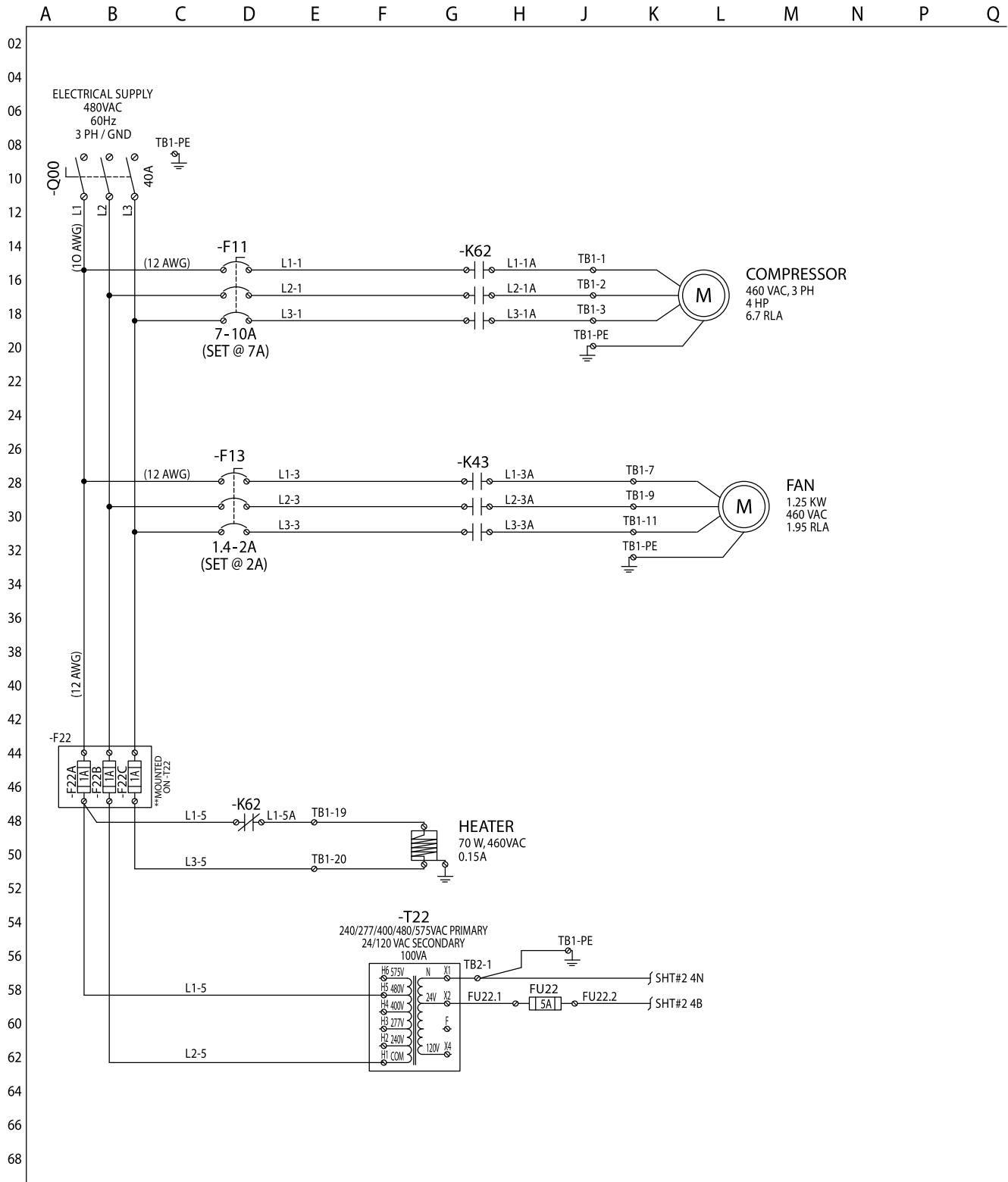



# ELECTRICAL SCHEMATICS

Models 1000 and 1250

Sheet 1 of 2

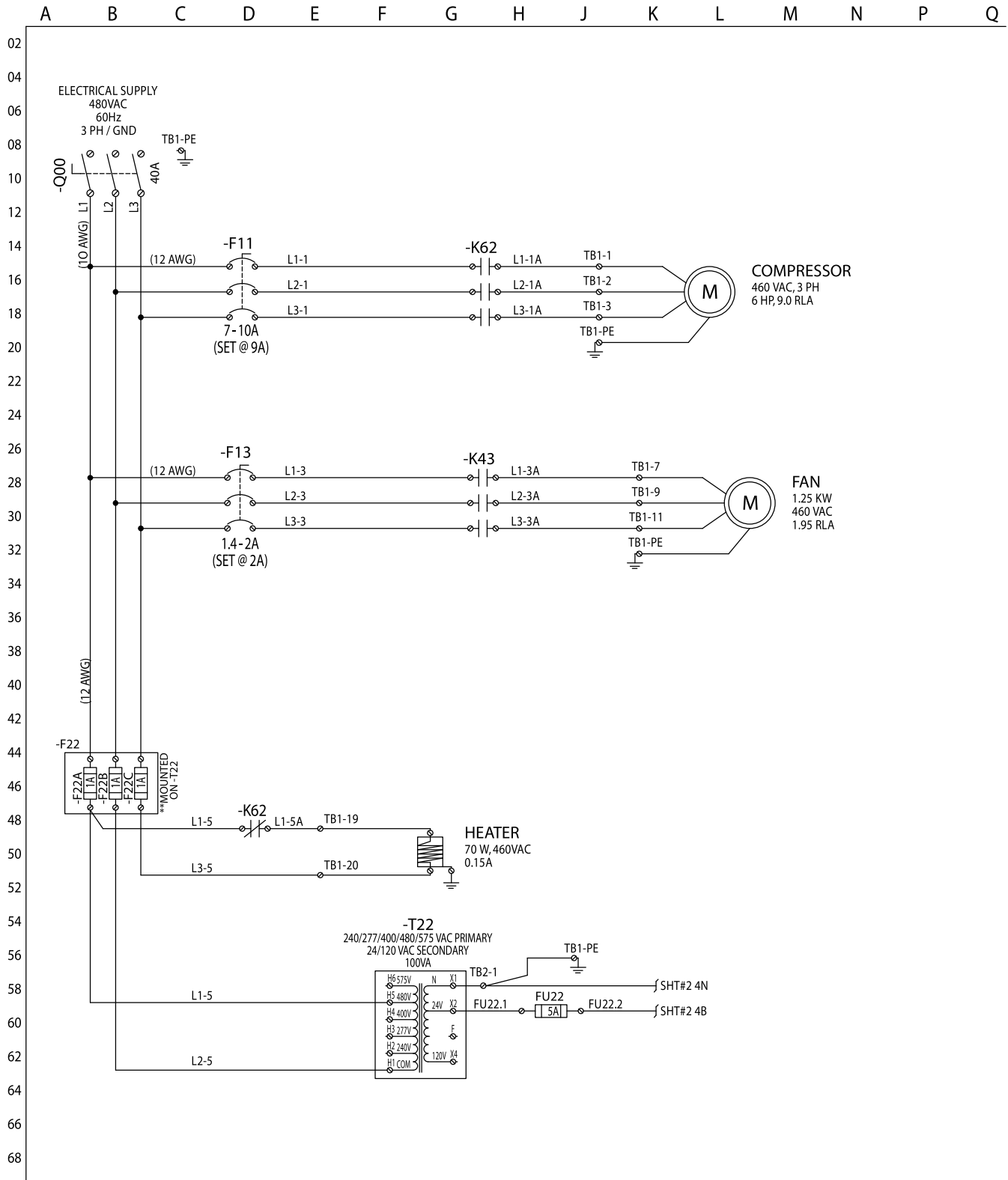

# ELECTRICAL SCHEMATICS

Models 1000 and 1250

Sheet 2 of 2

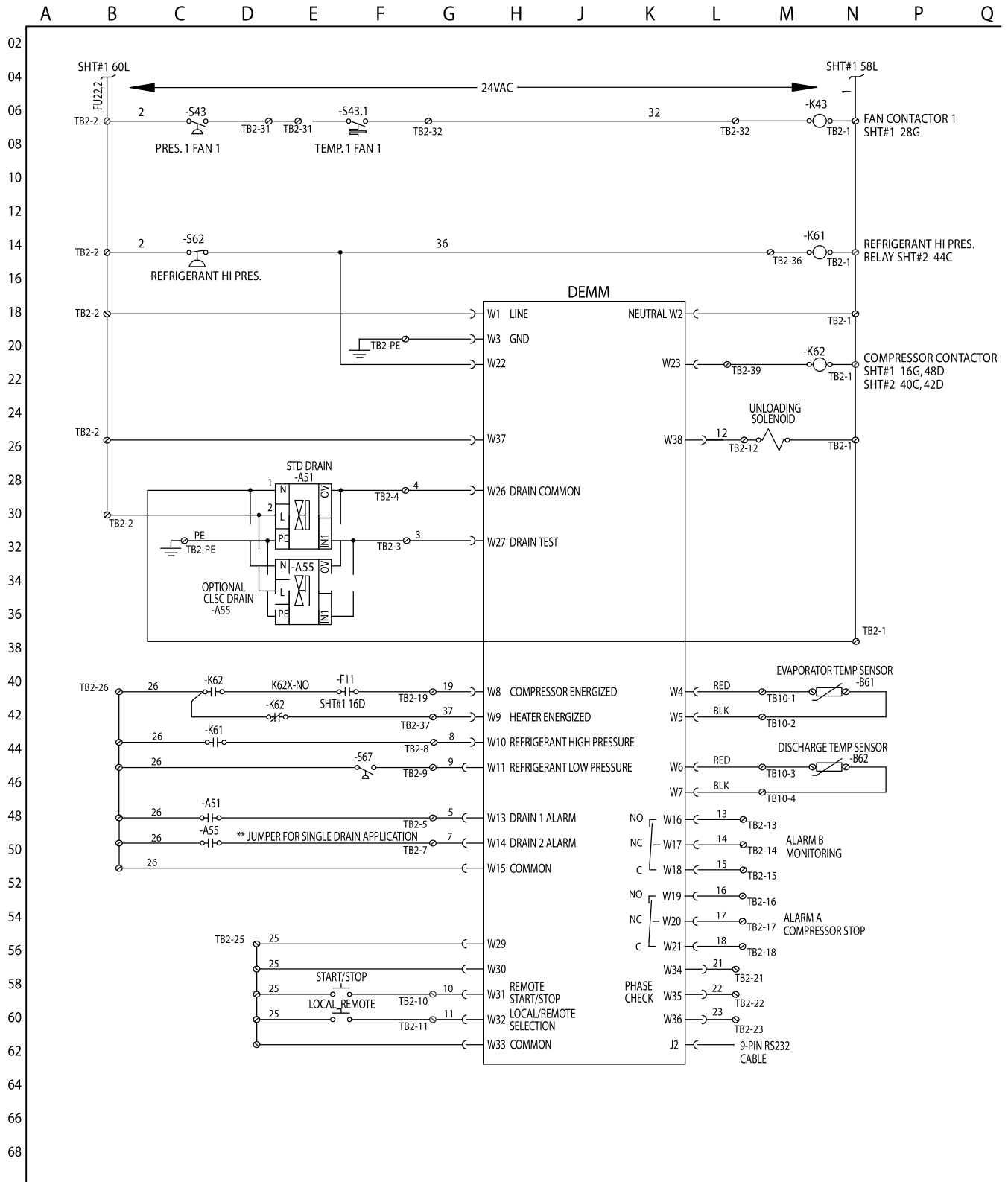

# ELECTRICAL SCHEMATICS

Models 1500 and 1750  
Sheet 1 of 2

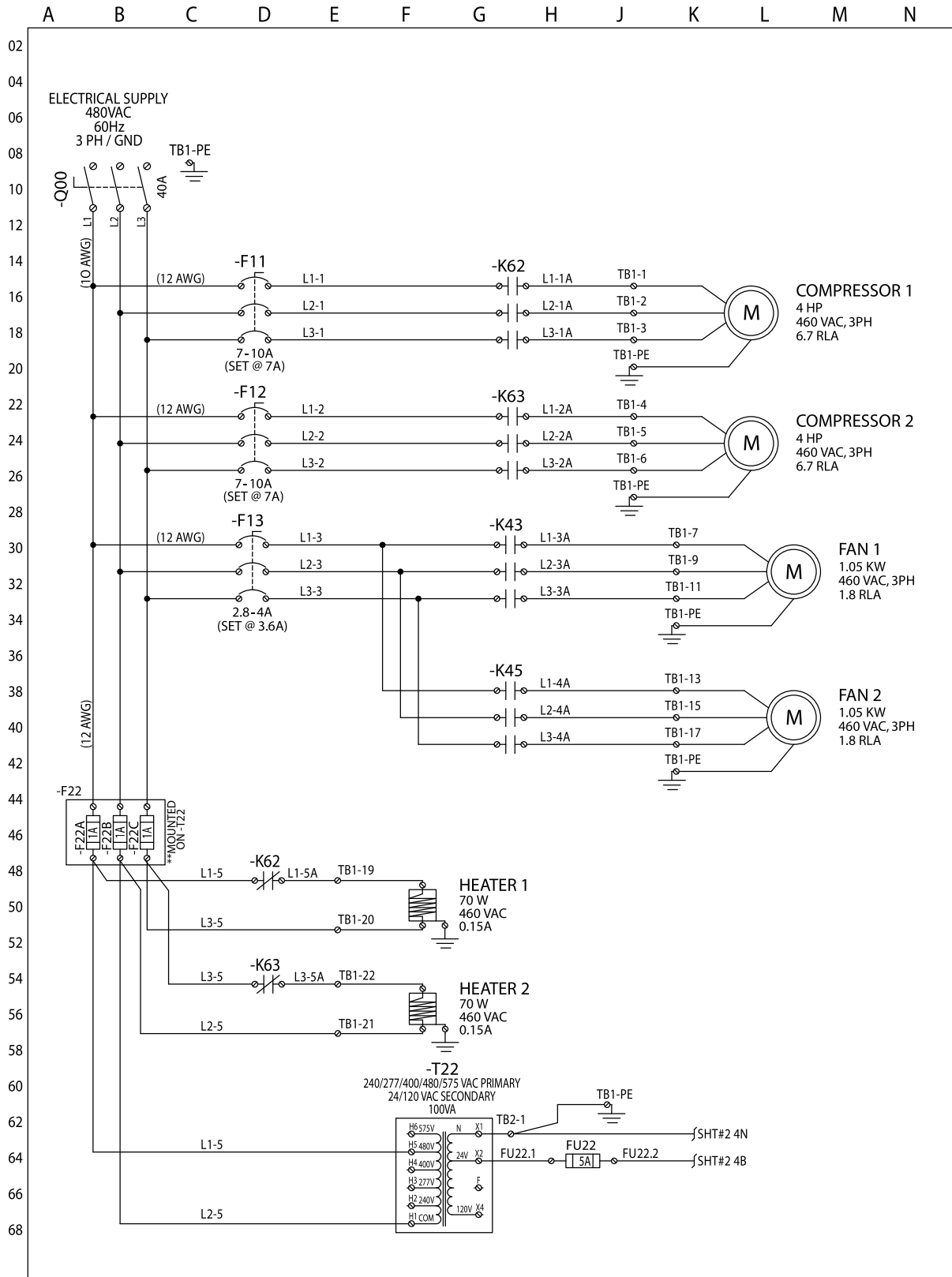

# ELECTRICAL SCHEMATICS

Models 1500 and 1750

Sheet 2 of 2

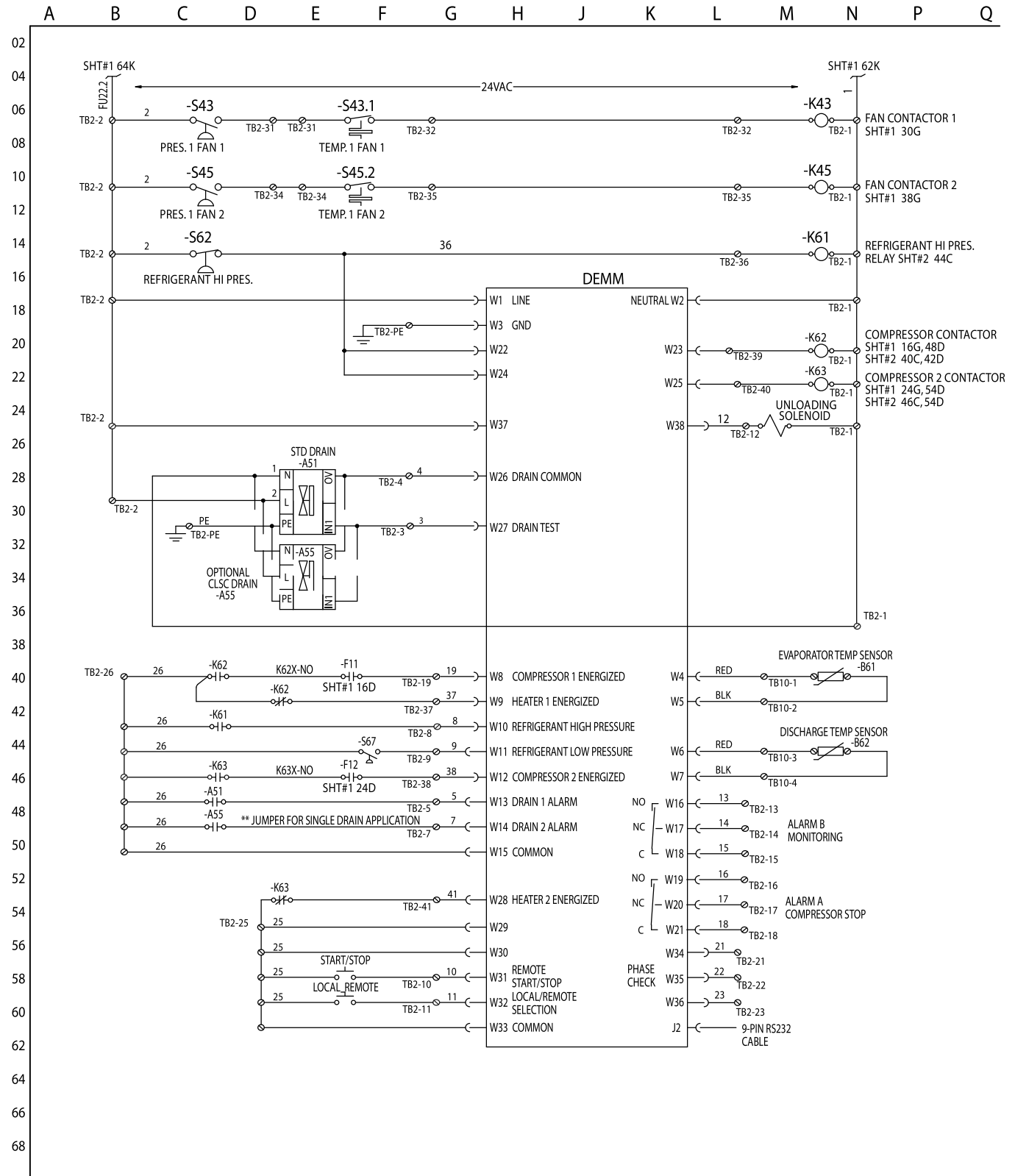

# ELECTRICAL SCHEMATICS

Models 2000 and 2500  
Sheet 1 of 2

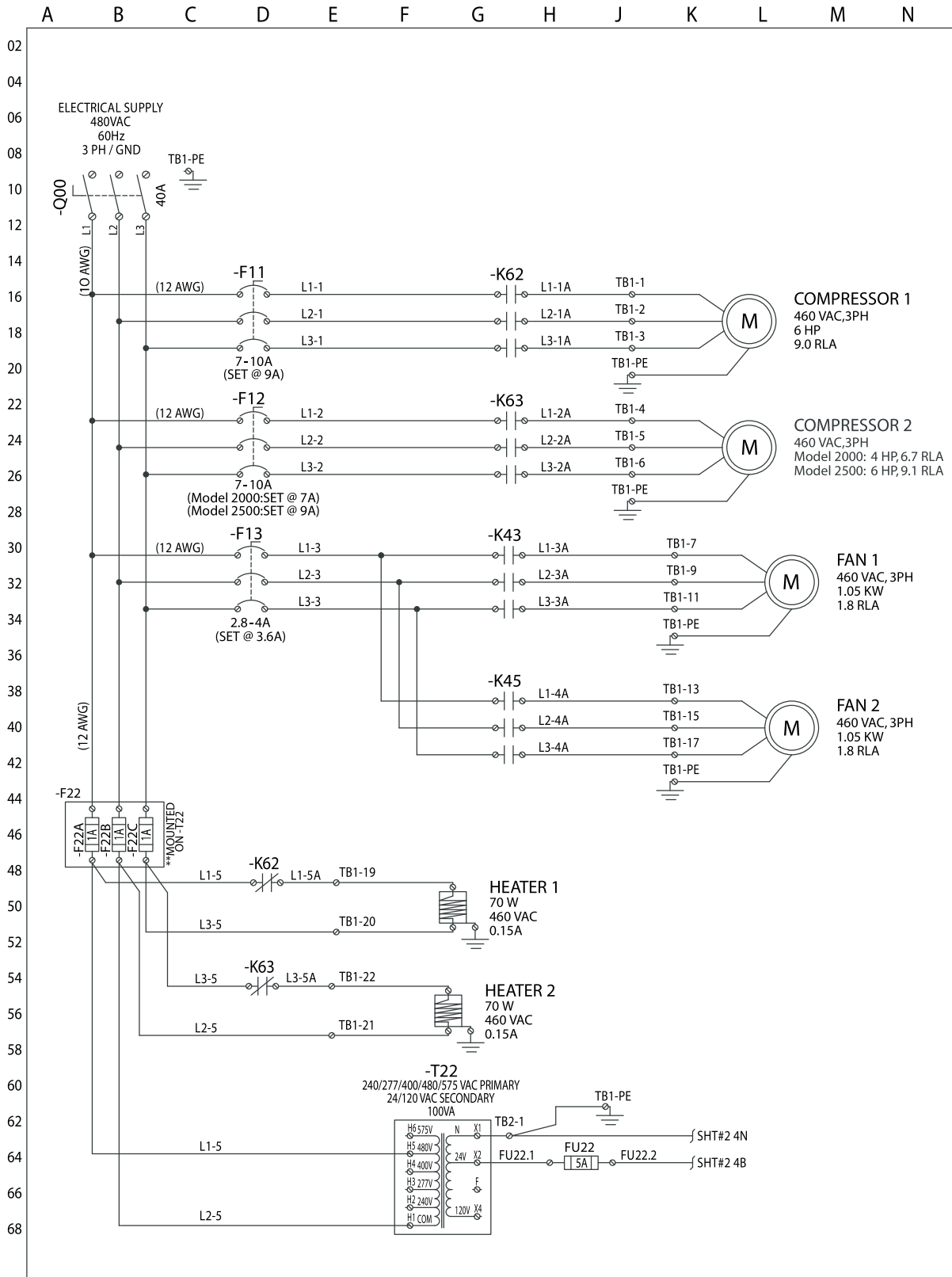

# ELECTRICAL SCHEMATICS

Models 2000 and 2500

Sheet 2 of 2

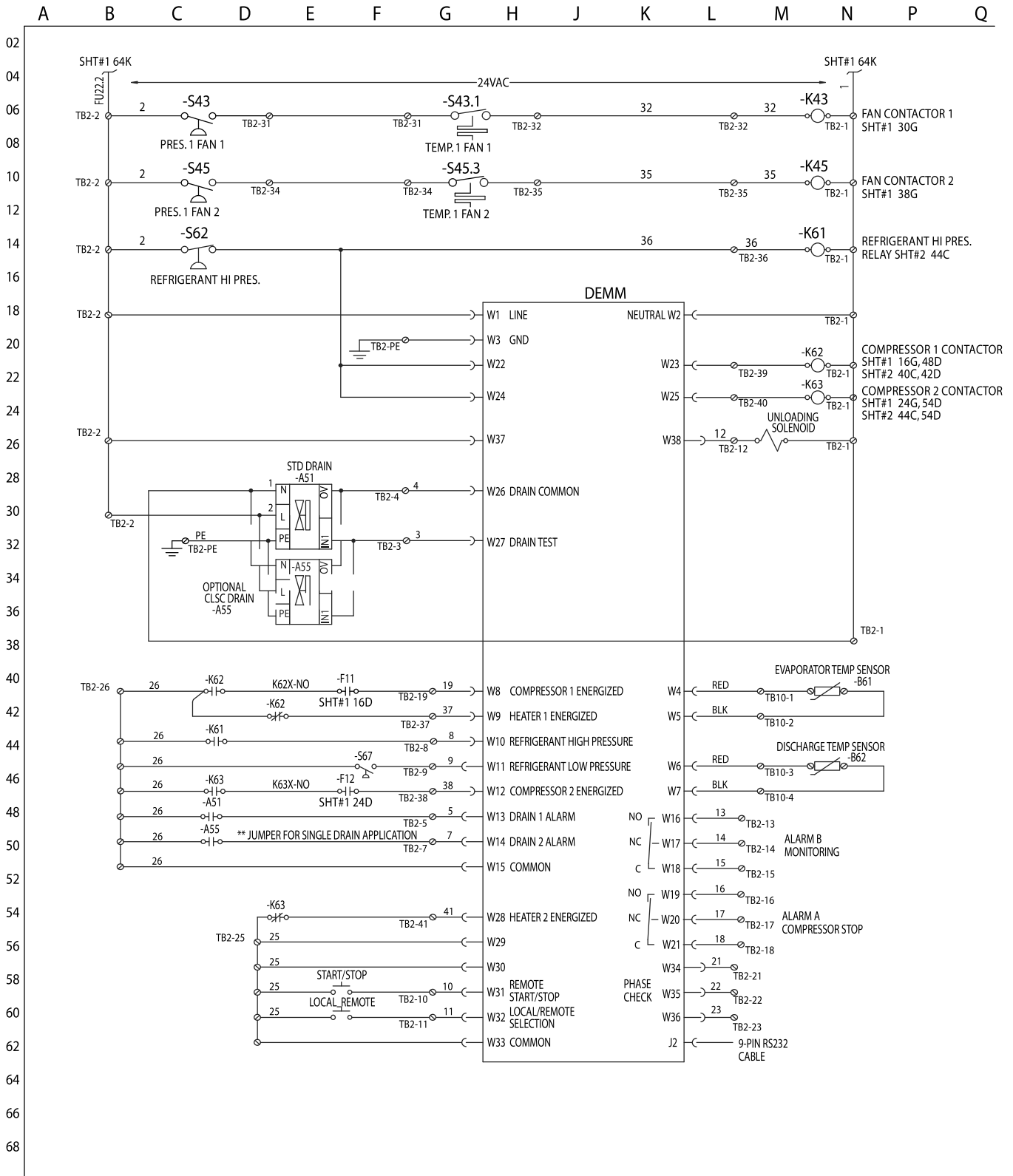

# ELECTRICAL SCHEMATICS

Model 3000  
Sheet 1 of 2

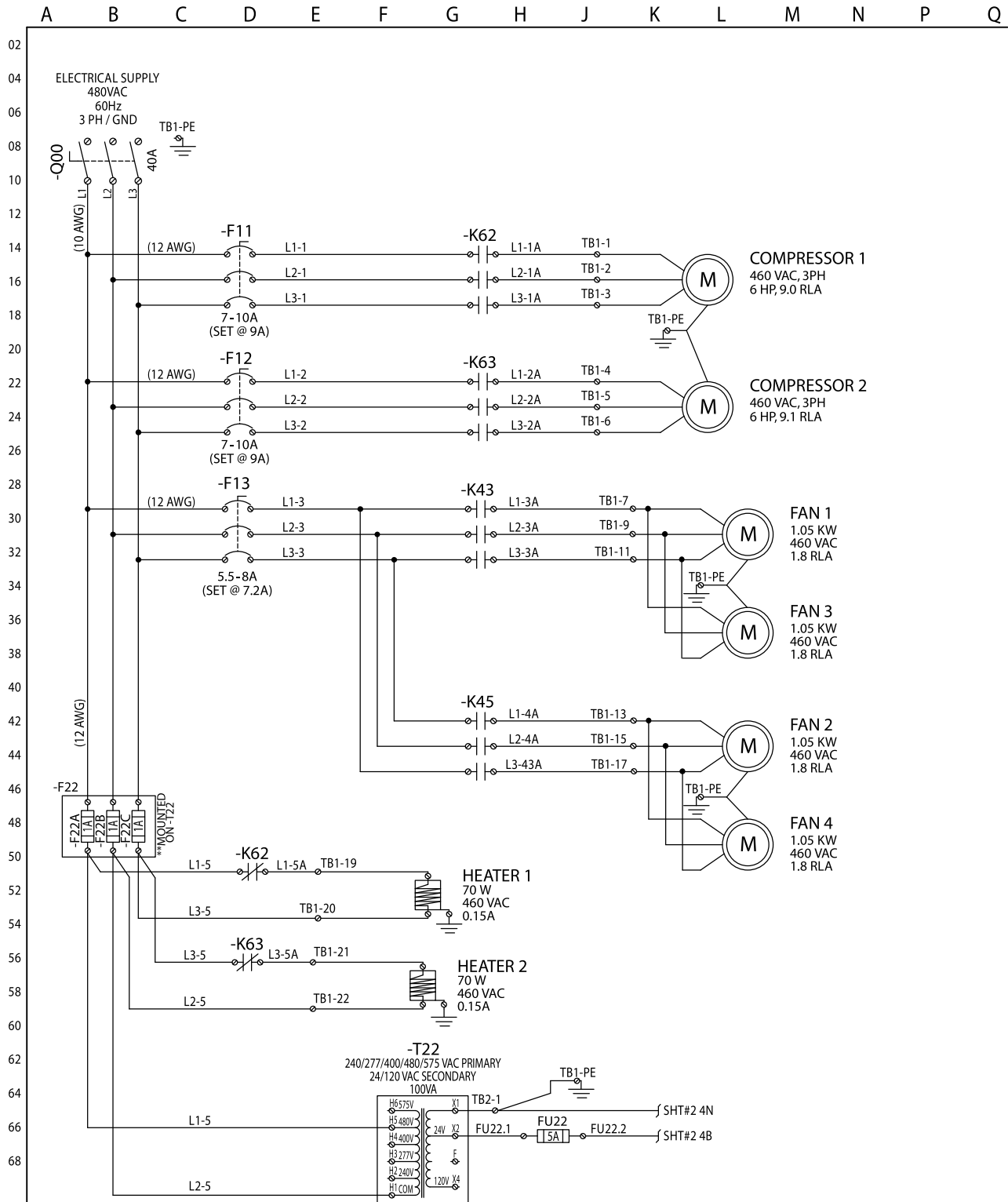

# ELECTRICAL SCHEMATICS

Model 3000  
Sheet 2 of 2

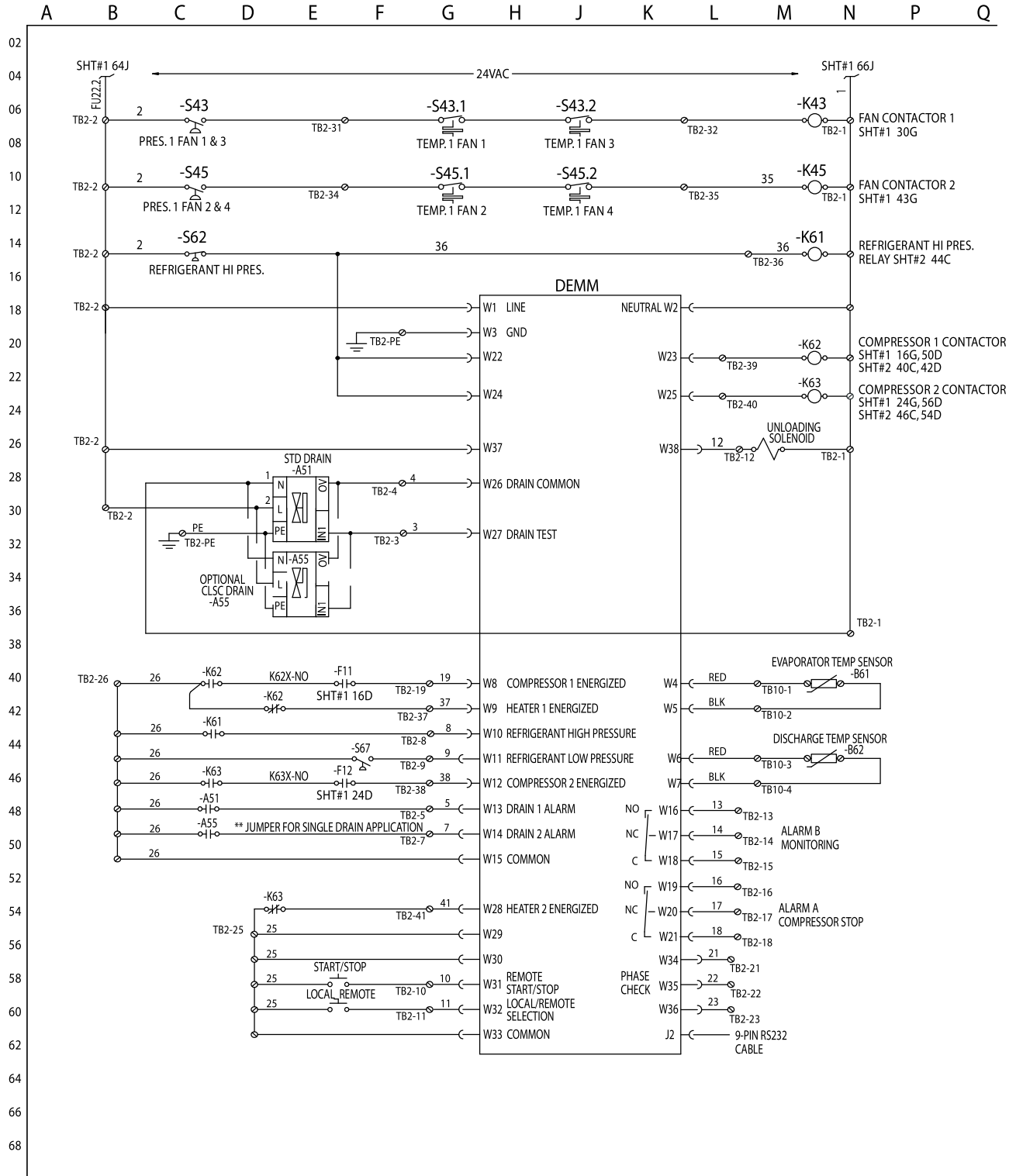

## DIMENSIONS / WEIGHTS

Model	Dimensions in (mm)						Weight Lb. (kg)	Inlet/Outlet Connections
	Height (A)	Width (B)	Depth (C)	(D)	(E)	(F)		
800	85.1/8 (2162)	48.1/2 (1232)	40.3/4 (1035)	12.1/2 (318)	12.7/8 (327)	8.3/4 (222)	1124 (510)	3" ANSI Fig.
1000	85.1/8 (2162)	48.1/2 (1232)	40.3/4 (1035)	12.1/2 (318)	12.7/8 (327)	8.3/4 (222)	1146 (520)	3" ANSI Fig.
1250	85.1/8 (2162)	48.1/2 (1232)	50.3/4 (1289)	13.1/4 (337)	11.1/4 (286)	8.1/2 (216)	1521 (690)	4" ANSI Fig.
1500	85.1/8 (2162)	48.1/2 (1232)	50.3/4 (1289)	13.1/4 (337)	11.1/4 (286)	8.1/2 (216)	1563 (709)	4" ANSI Fig.
1750	85.1/8 (2162)	55.1/8 (1400)	59.3/8 (1508)	13.1/4 (337)	31.1/4 (794)	9.1/8 (232)	1940 (880)	6" ANSI Fig.
2000	85.1/8 (2162)	55.1/8 (1400)	59.3/8 (1508)	13.1/4 (337)	31.1/4 (794)	9.1/8 (232)	1997 (906)	6" ANSI Fig.
2500	85.1/8 (2162)	55.1/8 (1400)	59.3/8 (1508)	13.1/4 (337)	31.1/4 (794)	9.1/8 (232)	2315 (1050)	6" ANSI Fig.
3000	85.1/8 (2162)	55.1/8 (1400)	59.3/8 (1508)	13.1/4 (337)	31.1/4 (794)	9.1/8 (232)	2646 (1200)	6" ANSI Fig.

NOTE: Dimensions and weights are for reference only. Request certified drawings for construction purposes.

### 800 - 1000 scfm

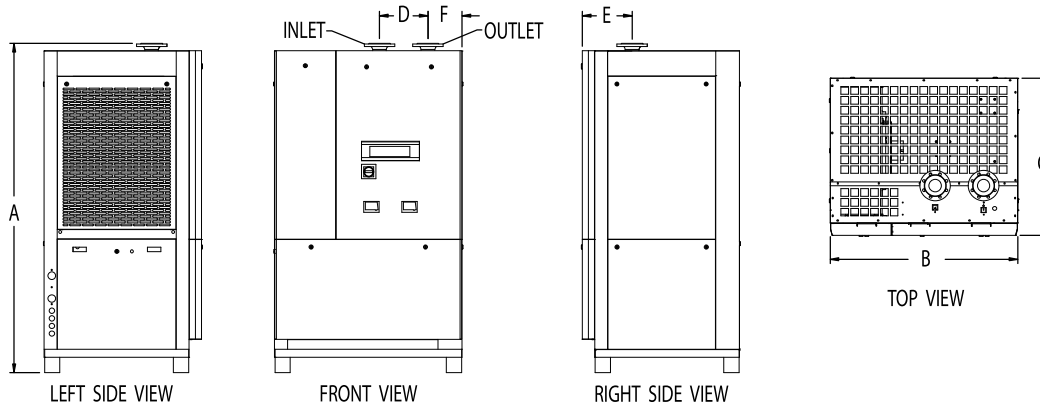

### 1250 - 1500 scfm

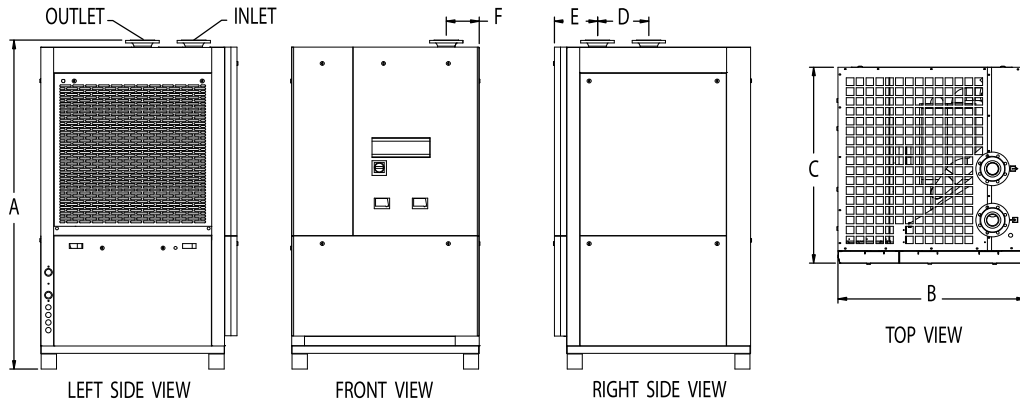

### 1750 - 3000 scfm

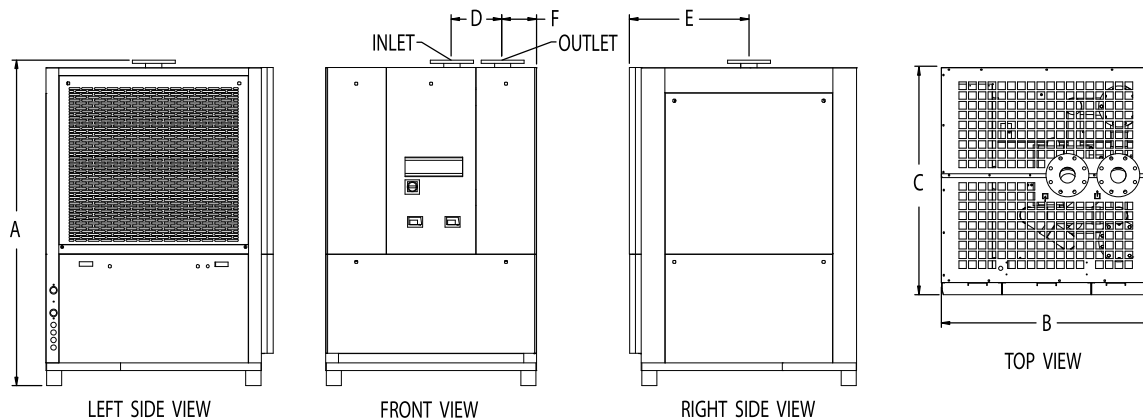

## ENGINEERING DATA

Model		800	1000	1250	1500	1750	2000	2500	3000	
<b>Air System Data</b>										
Rated Air Flow at 100°F & 100 psig Inlet, 100°F Ambient (scfm)	60 Hz, a-c	800	1000	1250	1500	1750	2000	2500	3000	
	60 Hz, w-c	920	1150	1438	1725	2013	2300	2875	3450	
Rated Air Flow at 95°F & 100 psig Inlet, 77°F Ambient (scfm)	50 Hz, a-c	848	1060	1325	1590	1855	2120	2650	3180	
	50 Hz, w-c	856	1070	1338	1605	1873	2140	2675	3210	
Minimum / Maximum Inlet Compressed Air Pressure		30 / 232 psig (2.1 / 16.0 barg)								
Minimum / Maximum Inlet Compressed Air Temperature		40° / 120°F (4° / 49°C)								
Minimum / Maximum Ambient Temperature		a-c 40° / 110°F (4° / 43°C)								
		w-c 40° / 130°F (4° / 54°C)								
Outlet Air Temperature (nominal at rated conditions)		85°F (29°C)								
<b>Refrigeration System Data</b>										
Compressor Type		Hermetic, Digital Scroll				Hermetic, Digital Scroll + Standard Scroll				
Refrigeration Compressor Horsepower		4	6	6	4 + 4	4 + 4	6 + 4	6 + 6	6 + 6	
Refrigeration Capacity @ Rated Flow (BTU/hr)*		60 Hz, a-c	40,800	47,000	58,800	69,000	80,500	98,500	118,800	141,300
		50 Hz, a-c	41,000	47,200	59,000	70,500	82,300	100,300	119,500	143,400
Refrigerant Type		R-404A								
Refrigerant Charge		See Data Tag on Dryer								
Suction Pressure Setting (nominal operating range)		75 - 85 psig (5.2 - 5.9 barg)								
Compressor Pressure Switch Setting (cut out / cut in)		High, a-c	450 / 350 psig (31.0 / 24.1 barg)							
		High, w-c	320 / 250 psig (22.1 / 17.2 barg)							
		Low	47 / 64 psig (3.2 / 4.4 barg)							
<b>Air-Cooled Condensers</b>										
Air Flow Across Condenser (cfm)		60 Hz	4,200	4,200	4,200	7,300	7,300	7,300	7,300	14,600
		50 Hz	3,500	3,500	3,500	6,100	6,100	6,100	6,100	12,200
Condenser Fan Switch Setting (cut in / cut out)		Fan 1	300 / 230 psig (20.7 / 15.9 barg)							
		Fan 2	N/A			325 / 255 psig (22.4 / 17.6 barg)				
<b>Water-Cooled Condensers</b>										
Water Regulating Valve Setting		255 psig (17.6 barg)								
Minimum Water Pressure Differential		40 psig (2.8 barg)								
Cooling Water Flow with 85°F (gpm)*		60 Hz	4.7	6.7	9.1	11	14	16	21	26
		50 Hz	4.4	6.2	8.5	10	13	15	20	24

**Notes**

\* 60 Hz: 35°F Evaporator & 100°F Ambient; 50 Hz: 35°F Evaporator & 77°F Ambient

## ENGINEERING DATA

Model	800	1000	1250	1500	1750	2000	2500	3000
<b>Electrical Data</b>								
<b>Nominal Voltage</b>	<b>230/3/60 **</b>							
Voltage Range	207 - 253							
Input Power @ Rated Flow (watts) *	4,710	6,730	7,400	9,770	13,010	14,870	16,840	18,200
Minimum Circuit Ampacity	21	26	26	41	41	46	52	59
Maximum Overcurrent Protector (amps)	30	40	40	60	60	75	80	90
Compressor Rated Load Amps ***	6.7	9.0	9.0	6.7 / 6.7	6.7 / 6.7	9.0 / 6.7	9.0 / 9.1	9.0 / 9.1
Compressor Locked Rotor Amps ***	48	70	70	48 / 48	48 / 48	70 / 48	70 / 70	70 / 70
Compressor Winding Resistance (ohms) ***	3.64	2.27	2.27	3.64 / 3.64	3.64 / 3.64	2.27 / 3.64	2.27 / 2.27	2.27 / 2.27
<b>Nominal Voltage</b>	<b>460/3/60</b>							
Voltage Range	414 - 506							
Input Power @ Rated Flow (watts) *	4,710	6,730	7,400	9,770	13,010	14,870	16,840	18,200
Minimum Circuit Ampacity	10	13	13	20	20	23	26	30
Maximum Overcurrent Protector (amps)	15	20	20	30	30	35	40	45
Compressor Rated Load Amps ***	6.7	9.0	9.0	6.7 / 6.7	6.7 / 6.7	9.0 / 6.7	9.0 / 9.1	9.0 / 9.1
Compressor Locked Rotor Amps ***	48	70	70	48 / 48	48 / 48	70 / 48	70 / 70	70 / 70
Compressor Winding Resistance (ohms) ***	3.64	2.27	2.27	3.64 / 3.64	3.64 / 3.64	2.27 / 3.64	2.27 / 2.27	2.27 / 2.27
<b>Nominal Voltage</b>	<b>575/3/60 **</b>							
Voltage Range	518 - 633							
Input Power @ Rated Flow (watts) *	4,710	6,730	7,400	9,770	13,010	14,870	16,840	18,200
Minimum Circuit Ampacity	8	11	11	16	16	19	21	24
Maximum Overcurrent Protector (amps)	12	17.5	17.5	25	25	30	35	35
Compressor Rated Load Amps ***	6.7	9.0	9.0	6.7 / 6.7	6.7 / 6.7	9.0 / 6.7	9.0 / 9.1	9.0 / 9.1
Compressor Locked Rotor Amps ***	48	70	70	48 / 48	48 / 48	70 / 48	70 / 70	70 / 70
Compressor Winding Resistance (ohms) ***	3.64	2.27	2.27	3.64 / 3.64	3.64 / 3.64	2.27 / 3.64	2.27 / 2.27	2.27 / 2.27
<b>Nominal Voltage</b>	<b>380-420/3/50</b>							
Voltage Range	342 - 462							
Input Power @ Rated Flow (watts) *	3,010	4,330	4,730	6,250	8,320	9,510	10,780	11,650
Minimum Circuit Ampacity	10	13	13	20	20	23	26	30
Maximum Overcurrent Protector (amps)	15	20	20	30	30	35	40	45
Compressor Rated Load Amps ***	6.7	9.0	9.0	6.7 / 6.7	6.7 / 6.7	9.0 / 6.7	9.0 / 9.1	9.0 / 9.1
Compressor Locked Rotor Amps ***	48	70	70	48 / 48	48 / 48	70 / 48	70 / 70	70 / 70
Compressor Winding Resistance (ohms) ***	3.64	2.27	2.27	3.64 / 3.64	3.64 / 3.64	2.27 / 3.64	2.27 / 2.27	2.27 / 2.27

### Notes

\* 60 Hz: 35°F Evaporator & 100°F Ambient; 50 Hz: 35°F Evaporator & 77°F Ambient

\*\* 230/3/60 and 575/3/60 units use equipment transformers on incoming power. Compressor and fan voltage is 460/3/60.

\*\*\* Where two values are shown, the first is for the digital scroll compressor and the second is for the standard scroll compressor.

## TROUBLESHOOTING GUIDE

SYMPTOM	POSSIBLE CAUSE(S)	CORRECTIVE ACTION
<b>A) Water downstream of dryer</b>	<ol style="list-style-type: none"> <li>1. Residual free moisture remaining in downstream pipelines.</li> <li>2. Air bypass system is open.</li> <li>3. Inlet and Outlet connections are reversed.</li> <li>4. Air lines downstream of dryer are exposed to temperatures below the dew point.</li> <li>5. Excessive free moisture (bulk liquid) at dryer inlet.</li> <li>6. Condensate not being drained.</li> <li>7. Dryer overloaded resulting in elevated dew point.</li> <li>8. Refrigeration system not functioning.</li> </ol>	<ol style="list-style-type: none"> <li>1. Blow out system with dry air.</li> <li>2. Check valve positions.</li> <li>3. Check for correct connection.</li> <li>4. Insulate or heat trace air lines exposed to low ambients or dry air to lower dew point.</li> <li>5. Install separator ahead of dryer.</li> <li>6. See C below.</li> <li>7. See C below.</li> <li>8. See C below.</li> </ol>
<b>B) High pressure drop across dryer</b>	<ol style="list-style-type: none"> <li>1. Excessive air flow.</li> <li>2. Freezing of moisture in evaporator because of refrigeration system fault.</li> <li>3. Filter loaded with solid particulates.</li> </ol>	<ol style="list-style-type: none"> <li>1. Check flow rate.</li> <li>2. See C below.</li> <li>3. Replace filter element.</li> </ol>
<b>C) Checkpoint faults</b> <ol style="list-style-type: none"> <li>1. Power on light off</li> <li>2. Compressor on light off</li> </ol> <ol style="list-style-type: none"> <li>3. Alarm/Service alert light on - check Display for active conditions SERVICE DRYER</li> </ol> <p>HIGH DISCHARGE TEMPERATURE</p> <p>LOW PRESSURE</p> <p>HIGH PRESSURE NOTE: If high refrigerant pressure occurs, switch must be manually reset</p> <p>HIGH EVAPORATOR TEMPERATURE (also observed as high reading on temperature indicator)</p> <p>DRAIN</p> <p>COMPRESSOR</p> <p>HEATER</p> <p>TEMP SENSOR</p>	<ol style="list-style-type: none"> <li>1. Power failure; open circuit.</li> <li>1. Compressor commanded off by manual switch or programmed schedule.</li> <li>2. Open circuit.</li> <li>3. Control circuit open on high or low pressure cutout.</li> </ol> <ol style="list-style-type: none"> <li>1. Service interval specified has elapsed.</li> </ol> <ol style="list-style-type: none"> <li>1. Air-cooled - Ambient temperature too high, clogged condenser fins, obstructed flow across condenser, faulty fan motor or fan control switch.  Water-cooled - Cooling temperature too high, flow too low, clogged strainer, faulty water regulating valve.</li> <li>2. Low refrigerant charge.</li> </ol> <ol style="list-style-type: none"> <li>1. Control system error.</li> <li>2. Low on refrigerant.</li> </ol> <ol style="list-style-type: none"> <li>1. Lack of condenser cooling. Air-cooled - Ambient temperature too high, clogged condenser fins, obstructed flow across condenser, faulty fan motor or fan control switch.</li> <li>2. Water-cooled - Cooling temperature too high, flow too low, clogged strainer, faulty water regulating valve.</li> </ol> <ol style="list-style-type: none"> <li>1. Dryer overloaded.</li> <li>2. Refrigeration system off or not cooling sufficiently.</li> </ol> <ol style="list-style-type: none"> <li>1. Drain line restricted or frozen.</li> <li>2. Drain mechanism faulty.</li> </ol> <ol style="list-style-type: none"> <li>1. Faulty compressor contactor.</li> <li>2. Faulty N.O. auxiliary contact on compressor contactor.</li> </ol> <ol style="list-style-type: none"> <li>1. Faulty compressor contactor.</li> <li>2. Faulty N.C. auxiliary contact on compressor contactor.</li> <li>3. Faulty heater.</li> </ol> <ol style="list-style-type: none"> <li>1. Temperature sensor or wiring to sensor is open (only the left-most LED in the temperature display will be illuminated).</li> <li>2. Temperature sensor or wiring to sensor is shorted (all of the LEDs in the temperature display will be illuminated).</li> </ol>	<ol style="list-style-type: none"> <li>1. Check for power to dryer.</li> <li>1. Check current command status.</li> </ol> <ol style="list-style-type: none"> <li>2. Check power to compressor.</li> <li>3. Check display for fault.</li> </ol> <ol style="list-style-type: none"> <li>1. Perform scheduled service.</li> </ol> <ol style="list-style-type: none"> <li>1. Check air temperature 6" in front of condenser; Clean condenser and check for free air flow; Check fan and switch operation.  Check cooling medium temperature and flow, clean strainer, check valve operation.</li> <li>2. Check system pressures/temperatures.</li> </ol> <ol style="list-style-type: none"> <li>1. Contact qualified technician or manufacturer's service department.</li> </ol> <ol style="list-style-type: none"> <li>1. Check air temperature 6" in front of condenser; Clean condenser and check for free air flow; Check fan and switch operation.</li> <li>2. Check cooling medium temperature and flow, clean strainer, check valve operation.</li> </ol> <ol style="list-style-type: none"> <li>1. Check compressed air inlet flow, temperature, and pressure.</li> <li>2. Check power to unit, power to compressor, Low or High pressure faults. Have qualified technician evaluate system.</li> </ol> <ol style="list-style-type: none"> <li>1. Open drain line.</li> <li>2. Check drain by pressing "Push to Test" button on control panel. If faulty, isolate drain. Rebuild automatic drain.</li> </ol> <ol style="list-style-type: none"> <li>1. Check wiring and operation of contactor.</li> <li>2. Check wiring and operation of auxiliary contact.</li> </ol> <ol style="list-style-type: none"> <li>1. Check wiring and operation of contactor.</li> <li>2. Check wiring and operation of auxiliary contact.</li> <li>3. Check heater element for continuity.</li> </ol> <ol style="list-style-type: none"> <li>1. Replace sensor or repair wiring.</li> </ol> <ol style="list-style-type: none"> <li>2. Replace sensor or repair wiring.</li> </ol>

NOTE: After fault correction, press reset button to clear display

**PARTS LIST:**

<b>PARTS DESCRIPTION</b>	<b>800</b>	<b>1000</b>	<b>1250</b>	<b>1500</b>	<b>1750</b>	<b>2000</b>	<b>2500</b>	<b>3000</b>
<b>Refrigerant Type</b> (see Serial Tag for charge amount)	R-404a	R-404a	R-404a	R-404a	R-404a	R-404a	R-404a	R-404a
<b>Compressor</b> - Digital Scroll	3221280	3221281	3221281	3221280	3221280	3221281	3221281	3221281
<b>Compressor</b> - Fixed Scroll	N/A	N/A	N/A	3221282	3221282	3221282	3210948	3210948
<b>Condenser Assembly</b> - Air-Cooled (includes condenser and fans)	5000763	5000763	5000764	5000765	5000766	5000766	5000767	5000768
<b>Contact</b> - Compressor - Digital Scroll	5002926	5002926	5002926	5002926	5002926	5002926	5002926	5002926
<b>Contact</b> - Compressor - Fixed Scroll	N/A	N/A	N/A	5002926	5002926	5002926	5002926	5002926
<b>Contact</b> - Fan Motor	5002926	5002926	5002926	5002926	5002926	5002926	5002926	5002926
<b>Auxiliary Contacts</b> - Compressor - NC	3221413	3221413	3221413	3221413	3221413	3221413	3221413	3221413
<b>Auxiliary Contacts</b> - Compressor - NO	3221412	3221412	3221412	3221412	3221412	3221412	3221412	3221412
<b>Control Board</b> - Digital Scroll Control	3227158	3227158	3227158	3227158	3227158	3227158	3227158	3227158
<b>Disconnect Switch</b>	3246083	3246083	3246083	3246083	3246083	3246083	3246083	3246083
<b>Fan Assembly</b> (includes motor, blade and guard)	3243804	3243804	3243804	3243805	3243805	3243805	3243805	3243805
<b>Filter/Dryer</b> - Liquid Line	3223812	3223812	3223812	3223812	3243615	3243615	3243616	3243616
<b>Fuse</b> - Control Board	5002943	5002943	5002943	5002943	5002943	5002943	5002943	5002943
<b>Fuse</b> - Control Transformer - primary	3246089	3246089	3246089	3246089	3246089	3246089	3246089	3246089
<b>Fuse</b> - Control Transformer - secondary	3246090	3246090	3246090	3246090	3246090	3246090	3246090	3246090
<b>Fuse</b> - Crankcase Heater	3246089	3246089	3246089	3246089	3246089	3246089	3246089	3246089
<b>Heater</b> , Crankcase	4010508	4010508	4010508	4010508	4010508	4010508	4010508	4010508
<b>Motor Starter Protector</b> - Compressor - Digital	5003506	5003506	5003506	5003506	5003506	5003506	5003506	5003506
<b>Motor Starter Protector</b> - Compressor - Fixed	5003506	5003506	5003506	5003506	5003506	5003506	5003506	5003506
<b>Motor Starter Protector</b> - Fan	3246077	3246077	3246077	3246078	3246078	3246078	3246078	3246079
<b>Relay</b> - High Pressure Cut-out	3246088	3246088	3246088	3246088	3246088	3246088	3246088	3246088
<b>Sensor</b> - Air Temperature	3228430	3228430	3228430	3228430	3228430	3228430	3228430	3228430
<b>Sensor</b> - Compressor Discharge Temperature	3246087	3246087	3246087	3246087	3246087	3246087	3246087	3246087
<b>Switch</b> - Fan Cut-out #1	3230765	3230765	3230765	3230765	3230765	3230765	3230765	3230765
<b>Switch</b> - Fan Cut-out #2	N/A	N/A	N/A	3230766	3230766	3230766	3230766	3230766
<b>Switch</b> - High Pressure Cut-out (air-cooled units)	3230770	3230770	3230770	3230770	3230770	3230770	3230770	3230770
<b>Switch</b> - Low Pressure Cut-out	3230769	3230769	3230769	3230769	3230769	3230769	3230769	3230769
<b>Transformer</b> - Control	3246082	3246082	3246082	3246082	3246082	3246082	3246082	3246082
<b>Valve</b> - Automatic Drain (complete)	3232366	3232366	3232366	3232366	3232366	3232366	3232366	3232366
<b>Valve</b> - Solenoid - Digital Scroll	3232517	3232517	3232517	3232517	3232517	3232517	3232517	3232517
<b>Valve</b> - Solenoid Assembly - Digital Scroll (includes solenoid valve and sound attenuation volumes)	3219039	3219039	3219039	3219039	3219039	3219039	3219039	3219039
<b>Valve</b> - Thermostatic Expansion (TXV)	3232550	3232550	3232550	3232550	3232532	3232532	3232533	3232533
<b>Water-Cooled Units Only</b>								
<b>Condenser</b> - Water-Cooled	3223341	3223341	3223342	3223343	3223346	3223346	3223346	3223345
<b>Replacement Screen</b> - Water Strainer	3230673	3230673	3230662	3230662	3230664	3230664	3230664	3230664
<b>Strainer</b> - Water	4009635	4009635	4009636	4009636	4009637	4009637	4009637	4009637
<b>Switch</b> - High Pressure Cut-out (water-cooled units)	3230771	3230771	3230771	3230771	3230771	3230771	3230771	3230771
<b>Valve</b> - Water Regulating	4006391	4006391	4006392	4006392	4006393	4006393	4006393	4006393
<b>230/3/60 Units Only</b>								
<b>Main Transformer</b> - 230/460	3230908	3230906	3230906	3230906	3230906	3230896	3230896	3230896
<b>575/3/60 Units Only</b>								
<b>Main Transformer</b> - 575/460	3230907	3230907	3230907	3230895	3230895	3230908	3230908	3230908
<b>Maintenance Kits</b>								
<b>Moisture Separator Filter</b> (includes separator elements & drain rebuild kit)	HESMK27S	HESMK27S	HESMK27S	HESMK27S	HESMK28S	HESMK28S	HESMK28S	HESMK28S
<b>Optional Oil Removal Filter</b> (includes separator elements, oil removal elements & drain rebuild kit)	HESMK47S	HESMK47S	HESMK47S	HESMK47S	HESMK48S	HESMK48S	HESMK48S	HESMK48S
<b>Rebuild Kit</b> - Automatic Drain	3210722	3210722	3210722	3210722	3210722	3210722	3210722	3210722

## NOTES

# WARRANTY

The manufacturer warrants the product manufactured by it, when properly installed, operated, applied, and maintained in accordance with procedures and recommendations outlined in manufacturer's instruction manuals, to be free from defects in material or workmanship for a period as specified below, provided such defect is discovered and brought to the manufacturer's attention within the aforesaid warranty period.

The manufacturer will repair or replace any product or part determined to be defective by the manufacturer within the warranty period, provided such defect occurred in normal service and not as a result of misuse, abuse, neglect or accident. Normal maintenance items requiring routine replacement are not warranted. The warranty covers parts and labor for the warranty period unless otherwise specified. Repair or replacement shall be made at the factory or the installation site, at the sole option of the manufacturer. Any service performed on the product by anyone other than the manufacturer must first be authorized by the manufacturer.

Unauthorized service voids the warranty and any resulting charge or subsequent claim will not be paid. Products repaired or replaced under warranty shall be warranted for the unexpired portion of the warranty applying to the original product.

The foregoing is the exclusive remedy of any buyer of the manufacturer's product. The maximum damages liability of the manufacturer is the original purchase price of the product or part.

THE FOREGOING WARRANTY IS EXCLUSIVE AND IN LIEU OF ALL OTHER WARRANTIES, WHETHER WRITTEN, ORAL, OR STATUTORY, AND IS EXPRESSLY IN LIEU OF THE IMPLIED WARRANTY OF MERCHANTABILITY AND THE IMPLIED WARRANTY OF FITNESS FOR A PARTICULAR PURPOSE. THE MANUFACTURER SHALL NOT BE LIABLE FOR LOSS OR DAMAGE BY REASON OF STRICT LIABILITY IN TORT OR ITS NEGLIGENCE IN WHATEVER MANNER INCLUDING DESIGN, MANUFACTURE OR INSPECTION OF THE EQUIPMENT OR ITS FAILURE TO DISCOVER, REPORT, REPAIR, OR MODIFY LATENT DEFECTS INHERENT THEREIN.

THE MANUFACTURER, HIS REPRESENTATIVE OR DISTRIBUTOR SHALL NOT BE LIABLE FOR LOSS OF USE OF THE PRODUCT OR OTHER INCIDENTAL OR CONSEQUENTIAL COSTS, EXPENSES, OR DAMAGES INCURRED BY THE BUYER, WHETHER ARISING FROM BREACH OF WARRANTY, NEGLIGENCE OR STRICT LIABILITY IN TORT.

The manufacturer does not warrant any product, part, material, component, or accessory manufactured by others and sold or supplied in connection with the sale of manufacturer's products.

## Warranty Period

Parts and labor for two (2) years from the date of shipment from the factory; heat exchangers are covered (parts only) for an additional three (3) years (total of five [5]). On units that manufacturer requests be returned to the factory, a one time removal/reinstallation labor allowance as noted in the Service Warranty Policies and Procedures Handbook will apply. Freight to the factory from the installation site and to the installation site from the factory will be paid by the manufacturer; means of transportation to be specified by manufacturer.

**AUTHORIZATION FROM THE SERVICE DEPARTMENT IS NECESSARY BEFORE MATERIAL IS RETURNED TO THE FACTORY OR IN-WARRANTY REPAIRS ARE MADE.**

**SERVICE DEPARTMENT: (724) 746-1100**



HANKISON, AN SPX BRAND  
1000 PHILADELPHIA STREET  
CANONSBURG, PA 15317-1700 U.S.A.  
TEL | 724 | 745 | 1555 FAX | 724 | 745 | 6040  
Email: [hankison.service@spx.com](mailto:hankison.service@spx.com)  
[www.hankisonintl.com](http://www.hankisonintl.com)



**SPX**  
DEHYDRATION & FILTRATION

© 2008 SPX Corporation. All rights reserved.

Improvements and research are continuous at Hankison. Specifications may change without notice.