

INSTRUCTION MANUAL

Models 8005, 8010, 8015

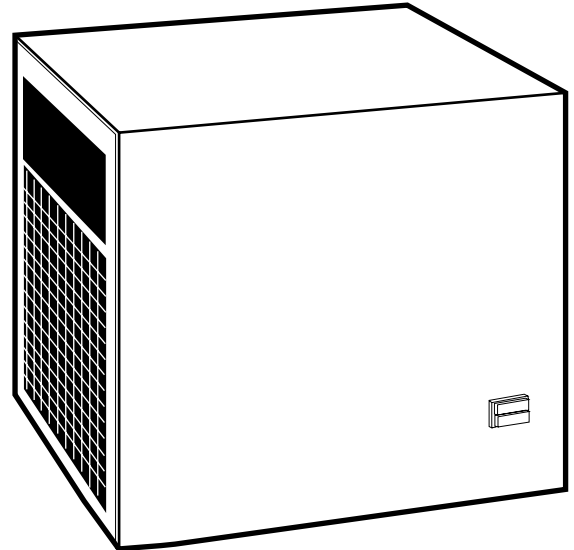

Contents

GENERAL SAFETY INFORMATION	2
RECEIVING, MOVING, UNPACKING	2
1.0 INSTALLATION	3
2.0 OPERATION	6
3.0 MAINTENANCE	7
SIZING	7
ENGINEERING DATA	8
DIMENSIONS / WEIGHTS	9
TROUBLESHOOTING	10
PARTS LIST	11
WARRANTY	12

REFRIGERATED

TYPE

COMPRESSED

AIR DRYERS

GENERAL SAFETY INFORMATION

1. PRESSURIZED DEVICES:

This equipment is a pressure containing device.
Do not exceed maximum operating pressure as shown on equipment serial number tag.
Make sure equipment is depressurized before working on or disassembling it for service.

2. ELECTRICAL:

This equipment requires electricity to operate.
Install equipment in compliance with all applicable electrical codes.
Standard equipment is supplied with electrical enclosures not intended for installation in hazardous environments.
Disconnect power supply to equipment when performing any electrical service work.

3. BREATHING AIR:

Air treated by this equipment may not be suitable for breathing without further purification.
Refer to applicable standards and specifications for the requirements for breathing quality air.

RECEIVING, MOVING, AND UNPACKING

A. RECEIVING

This shipment has been thoroughly checked, packed and inspected before leaving our plant.
It was received in good condition by the carrier and was so acknowledged.

Check for Visible Loss or Damage.

If this shipment shows evidence of loss or damage at time of delivery to you, insist that a notation of this loss or damage be made on the delivery receipt by the carrier's agent.

B. UNPACKING

Check for Concealed Loss or Damage.

When a shipment has been delivered to you in apparent good order, but concealed damage is found upon unpacking, notify the carrier immediately and insist on his agent inspecting the shipment.

Concealed damage claims are not our responsibility as our terms are F.O.B. point of shipment.

C. MOVING

In moving or transporting dryer, do not tip dryer onto its side.

D. STORAGE

IMPORTANT - Do not store dryer in temperatures above 130°F, 54.4°C.

IMPORTANT:
READ PRIOR TO STARTING THIS EQUIPMENT

1.0 INSTALLATION

1.1 Location

- A. For typical placement in a compressed air system, see drawing.
- B. Air compressor intake - Locate air compressor so that contaminants potentially harmful to the dryer (e.g. ammonia) are not drawn into the air system.
- C. Free air flow - Do not block either side of the cabinet. Leave 12 inches (305 mm) on each side of cabinet for free air flow. Standard units are designed to operate in ambients from 35 to 110°F (2 to 43°C).
- D. Installations in altitudes above 4500 feet (1370 meters) -
 Dryer is adjusted to operate in altitudes up to 4500 feet (1370 meters).
 If dryer is installed in an altitude above this, and has not been preset at the factory for this altitude, contact manufacturer's Service Department.

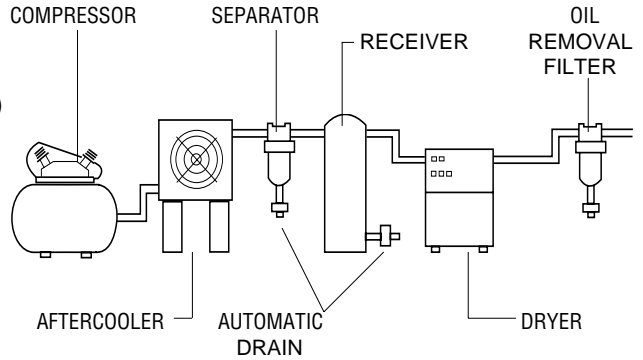

TYPICAL COMPRESSED AIR SYSTEM

NOTE

Outdoor installation- Standard units are designed for indoor installation. Contact manufacturer if installing outdoors.

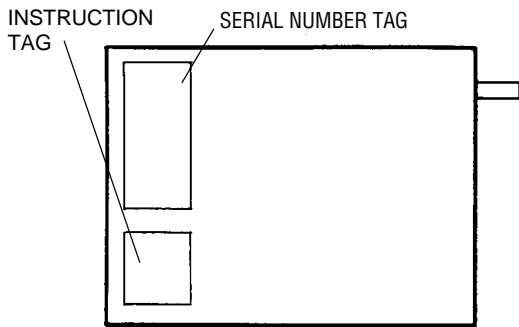

TOP VIEW

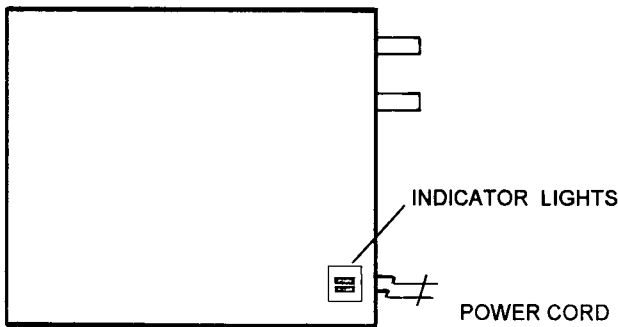
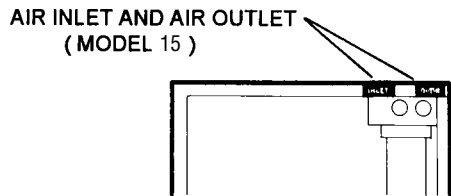

FRONT VIEW

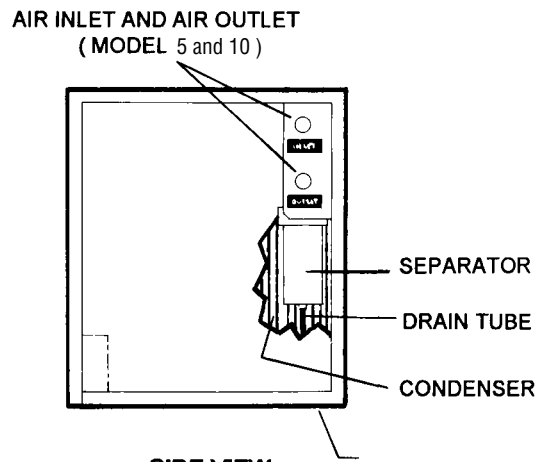

SIDE VIEW

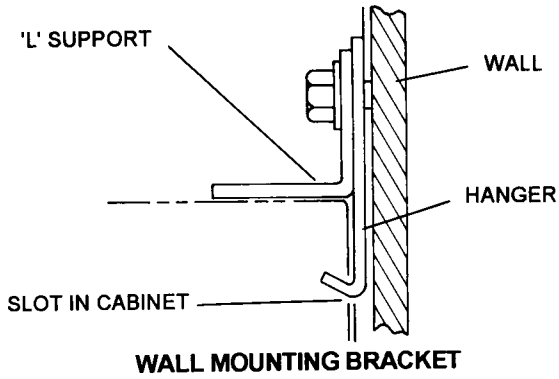

1.2 Mounting

- A. Wall mounting - Dryer may be mounted using the wall mounting bracket supplied. Keyhole slots are also provided in the cabinet as an optional mounting method.
- B. Base mounting - Dryer may be installed on a suitable shelf or floor stand.

1.3 Piping connections

- A. Air Inlet - Connect compressed air line from air source to air inlet.

WARNING

Refer to Serial Number Tag for maximum working pressure.
Do not exceed dryer's Maximum Working Pressure

NOTE

Install dryer in air system at highest pressure possible (e.g. before pressure reducing valves)

NOTE

Install dryer at coolest compressed air temperature possible. Maximum inlet compressed air temperature: 120°F (49°C). If inlet air exceeds this temperature, precool the air with an aftercooler.

- B. Air Outlet - Connect air outlet to downstream air lines.

- C. If servicing the dryer without interrupting the air supply is desired, piping should include inlet and outlet valves and an air by-pass valve.

NOTE

One-piece air by-pass valve, if ordered with dryer, has been shipped separately in carton for field mounting.

AIR INLET

AIR OUTLET

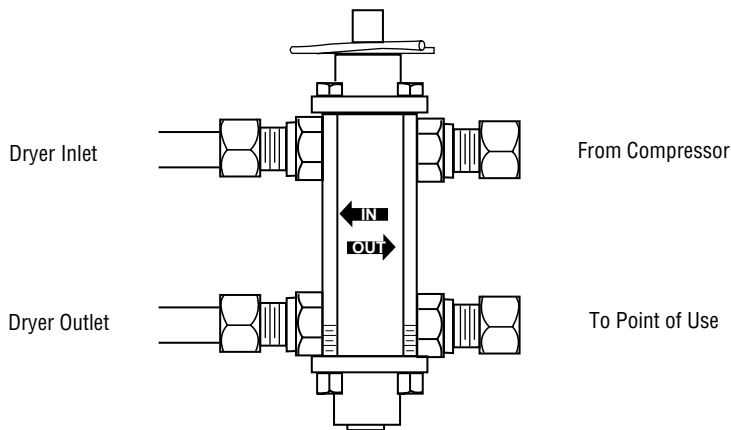

**OPTIONAL
AIR BY-PASS VALVE**

1.4 Electrical connections

- A. Dryer is designed to operate on the voltage, phase, and frequency listed on serial number tag.
- B. Dryer is supplied with a cord and plug. Install in receptacle of proper voltage.

NOTE

Refrigeration condensing unit is designed to run continuously and should NOT be wired to cycle on/off with the air compressor.

- C. Remote Alarm

Remote alarm can be wired at dryer installation site.

Connect alarm in parallel to high temperature light terminals in electrical box.

Amperage rating of alarm circuit:

	@ 115 VAC	@ 230 VAC
Resistive load amps	10.0	5.0
Inductive full load amps	5.8	2.9
Inductive locked rotor amps	34.8	17.9

1.5 Moisture separator

- A. Separator has an internal drain which automatically discharges collected condensate. It may be desirable to pipe the condensate to a suitable drain.

NOTE

Discharge is at system pressure. Drain line should be anchored.

- B. Separator has a knurled fitting with flexible drain tubing attached. Be sure knurled fitting is tightened by turning it counterclockwise before operating dryer.

NOTE

Condensate may contain oil.

Comply with applicable laws concerning proper disposal.

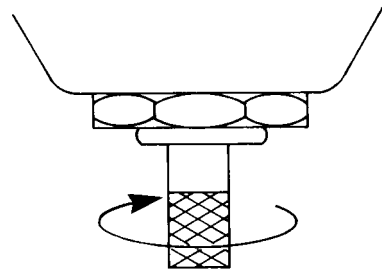

TO CLOSE
(TURN COUNTERCLOCKWISE)

KNURLED FITTING

2.0 OPERATION

2.1 Minimum/maximum operating conditions

- A. Maximum inlet air pressure: refer to unit serial number tag
- B. Minimum inlet air pressure: 20 psig (1.4 bar)
- C. Maximum inlet air temperature: 120°F (49°C)
- D. Maximum ambient temperature: 110°F (43°C)
- E. Minimum ambient temperature: 35°F (2°C)

2.2 Start-up

Energize dryer. Power-on light will illuminate.

2.3 Operating check points

Check the following on a periodic basis:

- A. Green power-on light is illuminated.
- B. Red high air temperature warning light is out.
The high air temperature warning light will illuminate when dryer is energized. Light should go out approximately 15 minutes after start-up. If light remains on after 30 minutes or illuminates after going out, refer to Troubleshooting Guide.
- C. Condensate is discharging from drain.

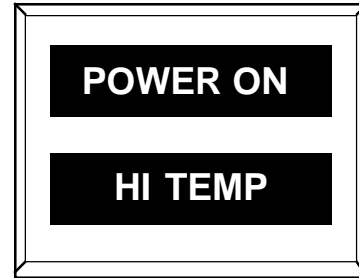

3.0 MAINTENANCE

3.1 Condenser coil -

Clean off accumulated dust and dirt monthly.

3.2 Moisture separator -

Replace filter sleeve when pressure drop across dryer is excessive.

3.3 Check separator daily to be sure automatic drain is discharging.

3.4 Blow down separator weekly by turning knurled fitting clockwise to open.

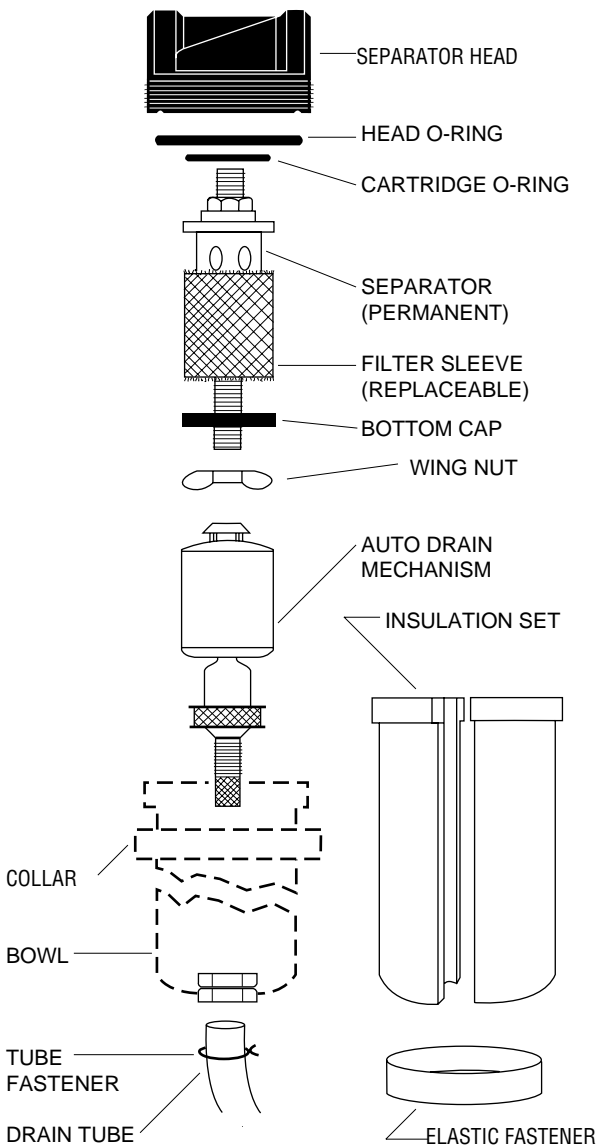

SIZING

Determining dryer capacity at actual operating conditions

To determine the maximum inlet flow capacity of a dryer at various operating conditions, multiply the rated capacity from Table 1 by the multipliers shown in Table 2.

Example: How many scfm can an air-cooled 10 scfm dryer handle when compressed air to be dried is at 80 psig and 90°F; ambient air temperature is 80°F; and a 38°F dew point temperature is desired?

Answer: $10 \times 1.17 \times 1.12 \times 1.0 = 13.1$ scfm.

TABLE 1

Rated capacity and pressure drop @ 100 psig inlet pressure, 100°F inlet temperature, and 100°F ambient temperature

MODEL		5	10	15
Rated capacity of air-cooled models (scfm)	@60 Hz	5	10	15
	@50 Hz	4.2	8.4	12.5
Pressure drop at rated capacity (psi)	@60 Hz	1.2	2.5	3.0
	@50 Hz	0.9	1.8	2.1

scfm x 0.0286 = m³/min

TABLE 2

Air capacity correction factors (multipliers)

INLET		INLET COMPRESSED AIR CONDITIONS				
PRESSURES psig	kgf/cm ²	INLET TEMPERATURES				
		80°F 27°C	90°F 32°C	100°F 38°C	110°F 43°C	120°F 49°C
50	3.5	1.35	1.05	0.84	0.69	0.56
80	5.6	1.50	1.17	0.95	0.79	0.66
100	7.0	1.55	1.23	1.00	0.82	0.70
125	8.8	1.63	1.31	1.07	0.91	0.74
150	10.5	1.70	1.37	1.13	0.95	0.80
175	12.3	1.75	1.42	1.18	0.99	0.84

COOLING MEDIUM		
AMBIENT TEMPERATURE		MULTIPLIER
°F	°C	
80	27	1.12
90	32	1.06
100	38	1.00
110	43	0.94

OUTLET DEWPOINT		
DEW POINT TEMPERATURE		MULTIPLIER
°F	°C	
38	3	1.0
40	4	1.1
45	7	1.2
50	10	1.3

Pressure Drop

To determine pressure drop at increased flows, multiply the pressure drop at rated conditions from Table 1 by the multiplier shown in Table 3 for the appropriate air flow rate and operating pressure.

Example: What is the pressure drop across a model 10 when flowing 12 scfm at 100 psig?

Answer: $12/10 = 1.2$; multiplier from table at $1.2 \times$ rated flow and 100 psig = 1.4; 1.4×2.5 psi = 3.0 psi.

TABLE 3

Pressure drop correction factors (Multipliers)

AIR FLOW	OPERATING PRESSURE psig / kgf/cm ²			
	60 / 4.2	100 / 7	180 / 12.6	200 / 14.0
2.0 x rated flow	5.4	3.5	2.1	1.9
1.5 x rated flow	3.2	2.1	1.2	1.1
1.2 x rated flow	2.1	1.4	0.8	0.7

ENGINEERING DATA

Minimum - Maximum Operating Conditions	5	10	15
Min.- Max. Inlet Air Pressure (compressed air at inlet to dryer)			
a) Standard		20 psig (1.4 bar) - 175 psig (12 bar)	
b) Optional		20 psig (1.4 bar) - 300 psig (21 bar)	
Max. Inlet Air Temp. (compressed air at inlet to dryer)		120°F (49°C)	
Min.-Max. Ambient Temperature		35°F (1.7°C) - 110°F (43°C)	
Refrigeration System Data	5	10	15
Compressor Type		Hermetic - Resistance Start, Induction Run - Non-Cycling	
Refrigeration Compressor Horsepower	1/20	1/6	1/5
BTU/HR - Refrigeration Only @ 35°F Evaporator & 100°F Ambient 60 Hz / 50 Hz	716 / 596	1010 / 842	1380 / 1150
Outlet Air Temperature (nominal at rated conditions)	40°F (4.4°C)	40°F (4.4°C)	40°F (4.4°C)
Refrigerant Type	R-134a	R-134a	R-134a
Refrigerant Charge		See dryer serial number tag	
Suction Pressure Setting (controlled by hot gas by-pass valve) (psig)	31.5	31.5	31.5
Air Flow Across Condenser (cfm) 60 Hz / 50 Hz	105 / 98	235 / 196	235 / 196

Electrical Data	5	10			15		
1) 115-1-60	115/1/60	115/1/60	208-230/1/60	220-240/1/50	115/1/60	208-230/1/60	220-240/1/50
Max.- Min. Voltage	127-104	127-104	253-187	264-198	127-104	253-187	264-198
Rated Load Amps	2.0	3.4	1.8	1.6	3.9	2.1	1.8
Locked Rotor Amps	13.6	18.0	8.5	8.7	22.0	13.7	10.7
Minimum Circuit Ampacity	2.5	4.0	2.2	2.0	4.7	2.6	2.2
Branch Circuit Fuse Size (amps)	15	15	15	15	15	15	15
Watts @ 35°F Evaporator & 100°F Ambient	171	280	280	223	290	290	257
Overload		Thermal & Current (Auto reset)					

ELECTRICAL

LEGEND

- 1LT - Power On Light
- 2LT - High Temperature Light
- SR - Start Relay
- MTR - Compressor
- FM - Fan Motor
- HTS - High Temperature Switch
- OL - Overload
- SOL - Electric Drain Valve (OPTIONAL)
- (*) - Electric Drain Valve (OPTIONAL)

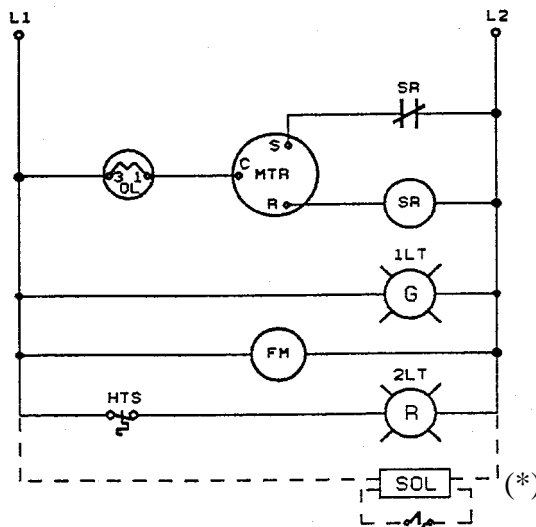

DIMENSIONS / WEIGHTS

DIMENSIONS INCHES [mm]			
MODEL	5	10	15
A	14 [356]	14 [356]	14 [356]
B	16 1/8 [410]	16 1/8 [410]	16 1/8 [410]
C	15 [381]	15 [381]	15 [381]
D	2 [51]	2 [51]	2 [51]
E	8 1/16 [205]	8 1/16 [205]	8 1/16 [205]
F	2 [51]	2 [51]	2 [51]
G	2 1/16 [52]	2 1/16 [52]	2 1/16 [52]
H	2 [51]	2 1/8 [54]	2 1/8 [54]
I	2 [51]	2 [51]	-
J	-	-	2 [51]
K	1 3/16 [30]	1 3/4 [44]	1 3/4 [44]
L	12 [305]	12 [305]	12 [305]
M	5 3/8 [137]	5 3/8 [137]	5 3/8 [137]
N	2 1/2 [64]	2 1/2 [64]	2 1/2 [64]

SHIPPING WEIGHTS LBS. [kg]			
MODEL	5	10	15
	50 [22.7]	57 [25.9]	65 [29.5]

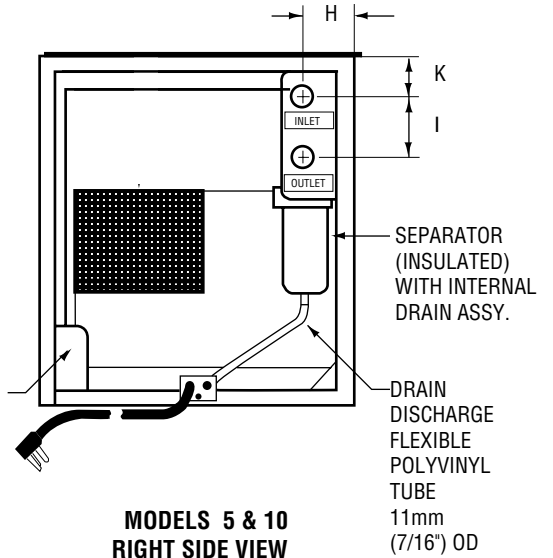
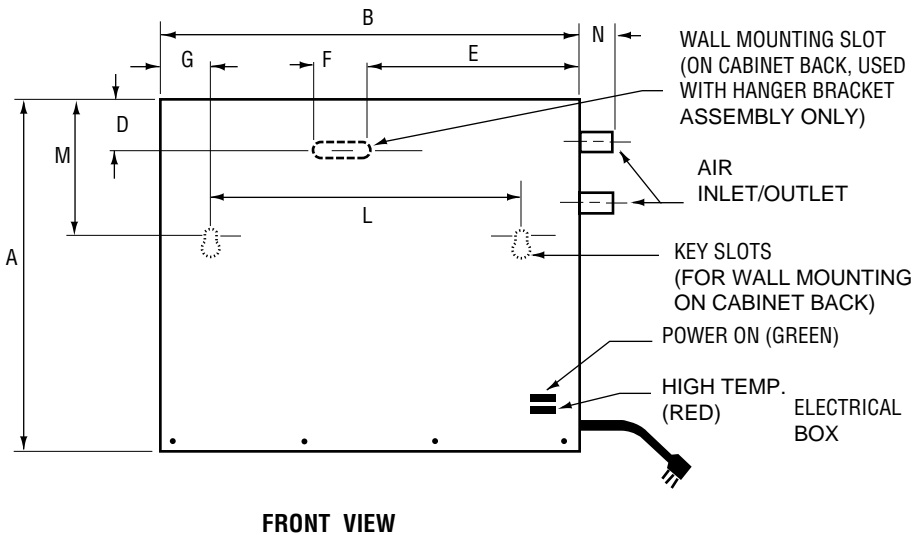
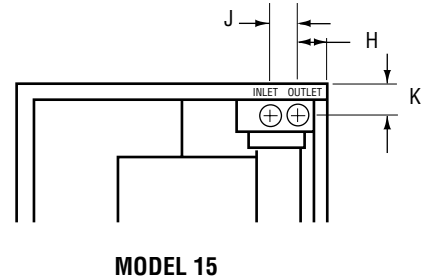
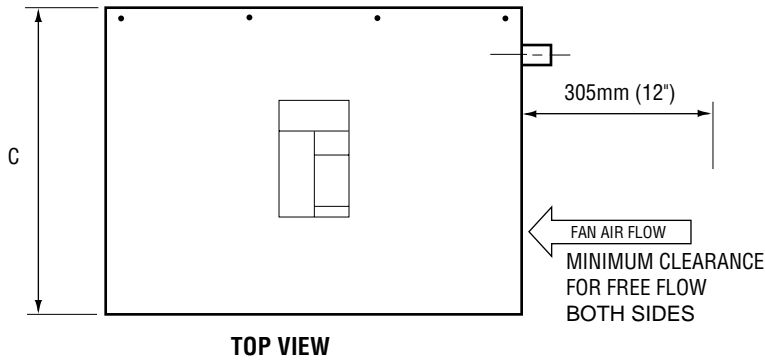

TROUBLESHOOTING GUIDE

SYMPTOM	POSSIBLE CAUSE(S)	CORRECTIVE ACTION
A) Water downstream of dryer	<ol style="list-style-type: none"> 1. Residual free moisture remaining in downstream pipelines 2. Air by-pass system is open 3. Inlet and Outlet connections are reversed 4. Temperatures surrounding air lines downstream of dryer have dropped below dryers dew point rating. 5. Excessive free moisture (bulk liquid) at dryer inlet 6. Condensate not being automatically drained Drain mechanism is clogged or inoperative. Drain line is restricted or frozen. Electric drains - timer not set to allow for sufficient condensate removal 7. Dryer overloaded resulting in elevated dew point. 8. Refrigeration system not functioning properly resulting in elevated dew point. 	<p>Blow out system with dry air</p> <p>Check valve positions Check for correct connection</p> <p>Insulate or heat trace air lines exposed to low ambients or dry air to lower dew point</p> <p>Install separator ahead of dryer</p> <p>Replace drain mechanism if inoperative</p> <p>Open drain line Electric drains - reset time so that all liquid is discharged Check inlet air temperature and pressure, flow rate (compressor capacity) and ambient air or water temperature. See D below</p>
B) High pressure drop across dryer	<ol style="list-style-type: none"> 1. Excessive air flow 2. Freezing of moisture in evaporator because of refrigeration system improperly functioning. 3. Separator filter clogged. 	<p>Check flow rate See D below</p> <p>Replace filter sleeve.</p>
C) High Temperature Alarm	<ol style="list-style-type: none"> 1. Dryer overloaded resulting in high air outlet temperature. 2. Refrigeration system not functioning properly resulting in high air outlet temperature. 3. Unit functioning normally but thermo static switch is malfunctioning or not securely mounted. 	<p>See A 7</p> <p>See D below</p> <p>Contact qualified refrigeration repairman or manufacturer's service department</p>
D) Refrigeration system not functioning properly 1. Power on light off 2. Refrigerant compressor cycles on and off	<ol style="list-style-type: none"> a. Power failure b. Line disconnect switch open c. Blown fuses, open breaker d. Faulty wiring, loose terminals <ol style="list-style-type: none"> a. High or low ambient conditions b. Air-cooled models - Dirty, clogged condenser fins, obstructed air flow across condenser, or non functioning fan motor or fan control switch. 	<p>Check power to unit Close disconnect switch Check for continuity Have electrician check electrical connections</p> <p>Check minimum/maximum temperature ranges Clean condenser and check for free air flow, if problem persists contact qualified refrigeration repairman or manufacturer's service department.</p>

PARTS LIST

PARTS DESCRIPTION	5	10	15	10		15	
	115/1/60 100/1/50	115/1/60 100/1/50	115/1/60 100/1/50	208-230/1/60	220-240/1/50	208-230/1/60	220-240/1/50
Condensing unit (air-cooled)	---	4130.120.7	4130.121.8	4130.120.8	4130.120.9	4130.121.9	4130.121.10
Compressor	4130.105.10	4130.108.34	4130.108.38	4130.108.61	4130.108.35	4130.108.39	4130.108.40
Overload	5925.575.10	5925.570.2	5925.578.1	5925.578.24	5925.570.3	5925.578.2	5925.578.3
Start relay	5945.655.10	5945.655.5	5945.683.1	5945.683.24	5945.655.6	5945.683.2	5945.683.3
Fan motor	6105.377.2	6105.239.1	6105.238.27	6105.237.4	6105.237.4	6105.238.28	6105.238.28
Fan blade	---	4140.228.2	4140.227.17	4140.228.2	4140.228.2	4140.227.17	4140.227.17
Condenser (air-cooled)	4130.110.10	4130.110.26	4130.111.18	4130.110.26	4130.110.26	4130.111.18	4130.111.18
Dryer/Strainer	4130.165.12	4130.165.14	4130.165.9	4130.165.14	4130.165.14	4130.165.9	4130.165.9
Hot gas by-pass valve	9802-1	9802-1	9802-1	9802-1	9802-1	9802-1	9802-1
Sensor, hi temp.	5930.189.1	5930.189.1	5930.189.1	5930.189.1	5930.189.1	5930.189.1	5930.189.1
Dual Light assy.	6350.454.8	6350.454.8	6350.454.8	6350.454.9	6350.454.9	6350.454.9	6350.454.9
Separator/Drain/Filter assy.	03.7083-04	03.7083-04	03.7080-08	03.7083-04	03.7083-04	03.7080-08	03.7080-08
Cartridge	07.4441-01	07.4441-01	07.4442-01	07.4441-01	07.4441-01	07.4442-01	07.4442-01
Sleeve	0734-1	0734-1	0734-2	0734-1	0734-1	0734-2	0734-2
Bowl	4460.079.3	4460.079.3	4460.079.3	4460.079.3	4460.079.3	4460.079.3	4460.079.3
Auto drain (175 psig)	05.4170-01	05.4170-01	05.4170.01	05.4170-01	05.4170-01	05.4170.01	05.4170.01
Auto drain (300 psig)	4330.185.1	4330.185.1	4330.185.1	4330.185.1	4330.185.1	4330.185.1	4330.185.1
Bowl gasket	9320.551.8	9320.551.8	9320.551.8	9320.551.8	9320.551.8	9320.551.8	9320.551.8
Drain tube	4720.604.1-1	4720.604.1-1	4720.604.1-8	4720.604.1-1	4720.604.1-1	4720.604.1-8	4720.604.1-8

Maintenance Kit

For Dryer Model	Kit Number	Kit Includes
5/10	RDMK1	Separator element, drain mechanism, insulation set & fastener, o-ring for bowl, drain tube & hose clamp, service reminder decal.
15	RDMK2	Separator element, drain mechanism, insulation set & fastener, o-ring for bowl, service reminder decal.

WARRANTY

The manufacturer warrants the product manufactured by it, when properly installed, operated, applied, and maintained in accordance with procedures and recommendations outlined in manufacturer's instruction manuals, to be free from defects in material and workmanship for a period of one (1) year from the date of shipment to the buyer by the manufacturer or manufacturer's authorized distributor, or eighteen months from the date of shipment from the factory, whichever occurs first (refrigerated dryers, models 25 thru 2300 scfm inclusive, for a period of two years from the date of shipment from the factory), provided such defect is discovered and brought to the manufacturer's attention within the aforesaid warranty period.

The manufacturer will repair or replace any product or part determined to be defective by the manufacturer within the warranty period, provided such defect occurred in normal service and not as a result of misuse, abuse, neglect or accident. Normal maintenance items requiring routine replacement are not warranted. For refrigerated dryers model 25 thru 2300 scfm, the manufacturer will include parts and labor for 18 months from the date of shipment from the factory and parts only for an additional six (6) months. On all other products, the warranty covers parts and labor for the warranty period. Repair or replacement shall be made at the factory or the installation site, at the sole option of the manufacturer. Any service performed on the product by anyone other than the manufacturer must first be authorized by the manufacturer.

Unauthorized service voids the warranty and any resulting charge or subsequent claim will not be paid.

Products repaired or replaced under warranty shall be warranted for the unexpired portion of the warranty applying to the original product.

The foregoing is the exclusive remedy of any buyer of the manufacturer's product. The maximum damages liability of the manufacturer is the original purchase price of the product or part.

THE FOREGOING WARRANTY IS EXCLUSIVE AND IN LIEU OF ALL OTHER WARRANTIES, WHETHER WRITTEN, ORAL, OR STATUTORY, AND IS EXPRESSED IN LIEU OF THE IMPLIED WARRANTY OF MERCHANTABILITY AND THE IMPLIED WARRANTY OF FITNESS FOR A PARTICULAR PURPOSE. THE MANUFACTURER SHALL NOT BE LIABLE FOR LOSS OR DAMAGE BY REASON OF STRICT LIABILITY IN TORT OR ITS NEGLIGENCE IN WHATEVER MANNER INCLUDING DESIGN, MANUFACTURE OR INSPECTION OF THE EQUIPMENT OR ITS FAILURE TO DISCOVER, REPORT, REPAIR, OR MODIFY LATENT DEFECTS INHERENT THEREIN.

THE MANUFACTURER, HIS REPRESENTATIVE OR DISTRIBUTOR SHALL NOT BE LIABLE FOR LOSS OF USE OF THE PRODUCT OR OTHER INCIDENTAL OR CONSEQUENTIAL COSTS, EXPENSES, OR DAMAGES INCURRED BY THE BUYER, WHETHER ARISING FROM BREACH OF WARRANTY, NEGLIGENCE OR STRICT LIABILITY IN TORT.

The manufacturer does not warrant any product, part, material, component, or accessory manufactured by others and sold or supplied in connection with the sale of manufacturer's products.

2/96

AUTHORIZATION FROM THE SERVICE DEPARTMENT IS NECESSARY BEFORE MATERIAL IS RETURNED TO THE FACTORY OR IN-WARRANTY REPAIRS ARE MADE.

SERVICE DEPARTMENT: (724) 746-1100

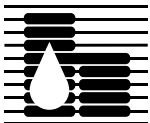

HANKISON
INTERNATIONAL

Division Of Hansen Inc.
Canonsburg, PA 15317-1700 U.S.A.
Tel 724-745-1555 Fax 724-745-6040
E-mail - service@hankisonintl.com