



**AIR COMPRESSOR
INSTALLATION AND
OPERATING INSTRUCTION
MANUAL**

TWO STAGE

WARNING

Before installing and operating this compressor, read and understand the safety precautions contained in LV-474 supplement to and part of CAP-600

IMPORTANT

Make a permanent record of the Model and Serial number of your machine here. You'll save time and expense by including this reference identification on replacement part orders.

ChallengeAIR <small>CURTIS-TOLEDO, INC. 1905 Kienlen Avenue St. Louis, MO 63133</small>	
REFER TO MODEL & SERIAL NUMBER. READ INSTAL. & OPERATION INSTR. DO NOT OPERATE LOWER THAN 500 R.P.M. OR ABOVE MAX. AS STIPULATED BY PERFORMANCE DATA SHEET.	
MODEL NO.	SERIAL NO.
<input type="text"/>	<input type="text"/>

***CONSULT FACTORY FOR SPECIAL APPLICATIONS**

CURTIS-TOLEDO, INC.

1905 Kienlen Avenue, St. Louis, Missouri 63133
phone: 314-383-1300 fax: 314-381-1439
email: info@curtistoledo.com website: www.fscurtis.com
Sales representatives in principal cities

INSTALLATION

CONGRATULATIONS on your new FSCurtis Challenge Air Compressor. Please examine the compressor for shipping damage(s) and if any are found report it immediately to the carrier.

Select a clean dry location with a rigid floor strong enough to support the compressor. If the compressor is to be located in an area where vibration is critical, properly engineered vibration mounts and flexible piping should be used. Remove the skid. **NOTE: The compressor should never be operated on the shipping skid.** Level the compressor so it can be bolted down securely. Before tightening the bolts, check to see that all four feet are resting on the foundation. Shim as necessary to eliminate stress on the receiver or base when the bolts are tightened. We suggest using a level for proper alignment.

Maximum ambient temperature in which the compressor and motor should be operated is 104°F. Therefore, adequate ventilation must be provided.

The suction openings of the compressor are equipped with a combination air filter-muffler to protect the compressor from normal dust and other harmful substances. If the air around the compressor is excessively hot, dusty, humid or contaminated with foreign gases (such as ammonia or acid fumes) move the filter-muffler to a remote point where the air is clean, cool and dry. Run a pipe to the compressor suction opening. If the run is over 50 feet in length, use a larger pipe to avoid excessive pressure drop. In order to fit the filter to the compressor, bush down the connections. Be sure piping and fittings are clean and free from dirt and chips. If the filter is installed outside, check to insure that it is located above the normal outside dust level, and that rain cannot enter the filter element. Where the relocation of the filter-muffler is not possible or feasible, an oil bath filter is recommended and is available from FSCurtis.

On basic or base mounted compressors run a discharge pipe to the receiver or optional aftercooler and bush up or down as necessary. The pipe should enter near the top of the receiver. Keep in mind that condensate may form in the discharge line; therefore, the lines should always be pitched to drain condensate away from the compressor. Always provide a safety relief valve in the discharge line between the compressor and in-line shutoff valves. If more than one compressor pumps into a common system, a check valve in the discharge line of each compressor is recommended to prevent moisture from entering the cylinder head when one compressor is idle. A globe or gate valve installed in the discharge line will allow compressor isolation from plant air system for compressor maintenance. (Note: A safety relief valve should be located between the compressor and the globe/gate valve.)

Check the electrical supply for voltage, phase, and frequency to see that they match the nameplate stampings on the motor, magnetic starter, solenoids, and other controls. Use electrical wires of adequate size to carry the full load current of the motor without excessive voltage drop. Charts are available from Curtis (upon request) to provide information on this. The motor must always be protected by a starter with properly sized thermal overload(s). The starter should protect the motor from overheating and burnout due to an overload, low voltage or single phasing of a 3-phase circuit. **Failure to install the proper starter and overloads will void the motor manufacturers warranty.** Follow the National Electric Code or local electric code in providing wiring, fusing and disconnect switches. **NOTE: Do not close the disconnect switch to start the compressor until the procedures outlined under "Startup Procedures" have been completed.**

LIMITED SAFETY PRECAUTIONS

(Also see supplement LV-474)

The following safety precautions are recommended in the use of this compressor:

1. Use a totally enclosed OSHA-approved belt guard to cover the drive assembly. Where possible, place the flywheel toward the wall, and mount the unit a minimum distance of 2 feet from the wall for maintenance convenience.
2. Turn off & lock out the electrical disconnect switch before working on the unit to prevent the unit from starting unexpectedly
3. Release all air pressure from the system before working on the unit and red tag all electrical control switches, for safety precaution.
4. Do not by-pass motor over-current protection.
5. Do not change the setting or in any way affect the operation of the safety valve.
6. Keep unit securely anchored so that movement will not put a strain on piping, wiring, or air receiver.

WARNING: Read and understand supplement LV-474 before installing and operating the compressor.

START-UP PROCEDURES

OIL RECOMMENDATION

Use Genuine **CURTISLUBEPLUS** Lubricants. Specially formulated for Curtis Reciprocating Air Compressors. Non-Detergent type with anti-foam, anti-rust and oxidation inhibitors.

Recommended **ISO68 RC-1000** Premium Reciprocating Compressor Lubricant, **Part no. VO411-3**, 12-quart case or VO411-2, 4 gallon case.

Recommended **ISO100 RC-1000A** Premium Reciprocating Compressor Lubricant **Part no. VO421-3**, 12-quart case or VO421-2, 4 gallon case.

CURTISLUBEPLUS Lubricants are available through your authorized Curtis distributor.

If the compressor is equipped with an automatic start-stop control (with pressure switch unloading), it is automatically unloaded upon starting, and will automatically load after attaining running speed. If the compressor is equipped with a constant speed control (pilot valve unloading), it is necessary to manually unload the compressor, if there is pressure in the discharge line, in order to achieve an unloaded start. The compressor must be manually loaded after the compressor has attained full running speed, there after, it functions automatically to maintain operating pressure until the unit is shut off.

Close the disconnect switch and start the compressor. Observe the direction of rotation, which should be counterclockwise when viewed from the flywheel side of the compressor on all models. For single-phase units, the direction of rotation is determined by the motor nameplate instructions, and is adjusted at the factory. For three-phase units, if the rotation is incorrect, stop the unit and interchange any two of the three wires to the motor at the disconnect switch. This will reverse the direction of rotation of the motor and compressor.

PREVENTIVE MAINTENANCE

A good maintenance program will add years of service to your air compressor. The following is recommended as a minimum maintenance program. (TURN OFF POWER BEFORE SERVICING.)

LUBRICATION

- For proper lubrication the compressor shall not be operated below the minimum or above the maximum R. P.M. recommended for the various models.
- Maintain oil level mid-way between the upper and lower lines of the crankcase sight gage. **NOTE ILLUSTRATION:**

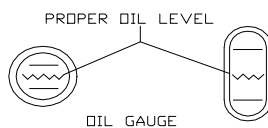

- Stop compressor to add and gauge oil.
- Do not fill above the upper line and do not operate compressor with oil level below the lower line.

DO NOT OVER FILL

- Change oil at the first 100 hours of operation and 1000 hours thereafter, or as required. It may be necessary to change oil more frequent due to abnormal humid and contaminated conditions.

DAILY MAINTENANCE

- Check and maintain oil level at centerline of sight glass and add oil as necessary.
- Drain condensate from receiver unless it is equipped with an automatic tank drain, in which case the drain should be checked weekly to see that it is operating. See automatic tank drain instructions.

- Check for unusual noise or vibration (See "Trouble Shooting".)

WEEKLY MAINTENANCE

- Clean the air filters. A clogged air filter can seriously affect the efficiency of the compressor and cause overheating and oil usage.
- Clean all external parts of the compressor and driver. Be sure to clean the intercooler-finned surface on two-stage compressors. A dirty compressor will cause abnormally high discharge temperature and resulting oil carbonization on internal valve components
- Check the safety valve manually (by pulling ring or lever) to see that it is not stuck.

MONTHLY MAINTENANCE

- Inspect the entire air system for leaks.
- Inspect condition of oil and change if necessary.
- Check drive belt tension and tighten if needed.

EVERY 3 MOS. OR 1,000 HRS. OF OPERATION

- Change oil.
- Inspect valves. Clean the carbon from valves and head if necessary.
- Check and tighten if necessary all bolts, nuts, etc.
- Check unloader operation.

*CHECKING BELT TENSION

The v-belt(s) should be adjusted so that a declination of about 3/8 – 1/2 inch will be obtained when it is pushed by a finger at the middle point as shown in Figure 1.

CAUTION: Over tightening the v-belt(s) will result in overloading of the motor and belt failure, while a loose belt will be slipping and resulting in an unstable speed, overheating the belt and high amp draw.

WARNING: Read and understand supplement LV-474 before installing and operating the compressor.

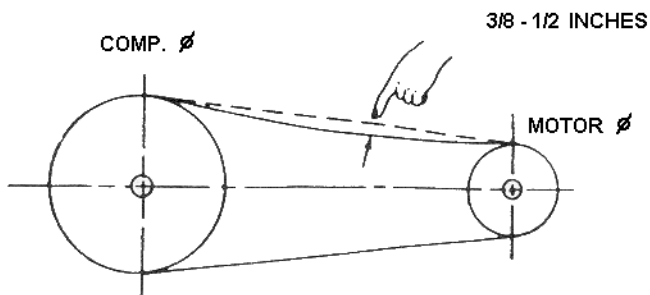

Figure 1

To change tension, loosen the motor hold-down bolts and slide the motor on the base, using a lever if necessary, or by turning the adjusting bolt at the end of the base.

Retighten motor hold-down bolts.

NOTE: Do not over tighten belts.

ELECTRIC MOTOR

Grease once a year with a good grade of lithium ball bearing grease, or as directed by the motor manufacturer.

VALVE INSPECTION AND MAINTENANCE

Valves should be inspected at regular intervals as recommended under "Maintenance" and cleaned or replaced when necessary. The valve can be serviced without disconnecting air piping or removing the head.

(Be sure the power to the motor is disconnected and all pressure released before starting to work on the compressor.)

On constant run models, it is necessary to remove the unloader piping before the valve plugs can be removed.

MODELS E-11 AND E-23 (Figures 2 and 3)

A. Disassembly:

1. Unbolt the outlet valve push cover (2601021510).
2. Remove the outlet valve push cover packing (2601021540), spring (2601320030) and valve plate (2601310180). **CAUTION: Steps 1 and 2 are for outlet valve.**
3. Remove the unloading connecting tube for Models E-11 and E-23.
4. Untighten four cylinder head fixed bolts.
5. Remove cylinder head carefully and turn it over.
6. Unbolt inlet valve receiver (2601310170).
7. Remove valve spring (2601310190) and valve plate (2601310180).

Valves should be inspected approximately every 1,000 hours of operation. Inspect the valve seats on cylinder head for dents, cracks or wear. Replace all defective parts. Remove carbon deposits and wash all valve components in a suitable non-flammable cleaning fluid.

B. Assembly:

1. Place outlet valve plate (2601310180) in position.
2. Place the outlet valve push cover packing (2601021540) in position.
3. Insert the spring (2601320030) into outlet valve push cover (2601021510).
4. Turn outlet valve push cover (2601021510) in position carefully.

5. Check the valves to see if they can move freely in their guides.
6. Turn over the cylinder head (2601021340).
7. Place the inlet valve plate (2601310180) in position.
8. Insert the small end of inlet valve spring (2601310190) into position of valve receiver (2601310170).
9. Screw inlet valve receiver in position.
10. Check the valves to see if they can move freely in their guides and do not pinch or bind between the seat and guard legs.

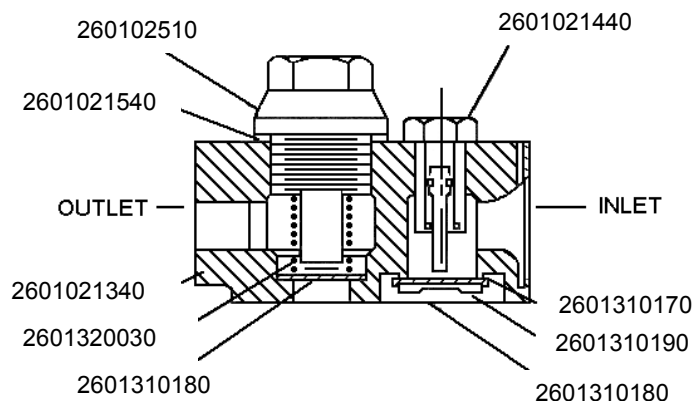

Figure 2

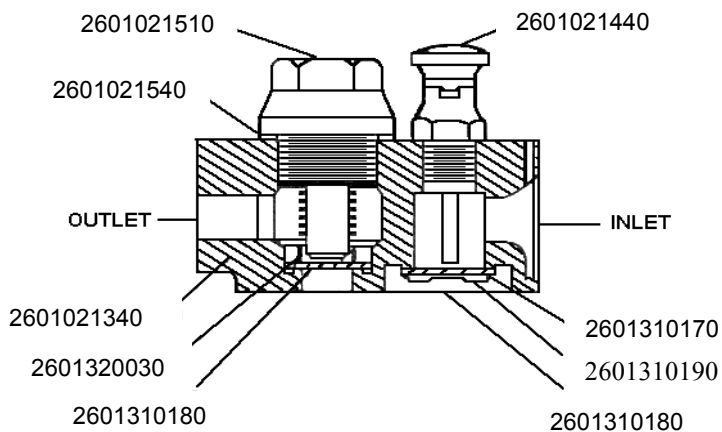

Figure 3

WARNING: Read and understand supplement LV-474 before installing and operating the compressor.

MODELS E-50, E-71 AND E-15 (Figures 4 and 5)**A. Disassembly of Inlet Valve Assembly (Figure 4).**

1. Untighten the hex nut.
2. Remove unloading fork (2601310700), unloading fork guide (2601310710), unloading spring (2601024470) and valve seat (2601310650).

CAUTION:

1. If a vise is used to hold the valve assembly, be careful not to clamp the assembly too tight.
2. Valve assembly should be inspected approximately every 1,000 hours of operation.
3. Inspect the valve seat for dents, cracks or wear.
4. Replace all defective parts.
5. Valve seats that might be worn after years of operation can be re-lapped or re-ground, in this case the recess in which the valve guard legs fit must also be cut down accordingly to ensure a same valve lift.
6. Remove carbon deposits and wash all valve components in a suitable non-flammable cleaning fluid.

B. Reassembly of Inlet Valve Assembly

1. Place valve spring (2601310690 and valve plate (2601310680) on valve receiver (2601310660).
2. Place valve seat (2601310650), unloading fork guide 2601310710, unloading spring (2601024470) and unloading fork (2601310700) respectively.
3. Tighten the valve assembly by tightening the hex nut.
4. Check the valves to see if they can move freely in their guides and do not pinch or bind between the seat and guard legs.

C. Disassembly of Outlet Valve Assembly (Figure 5)

1. Untighten the hex nuts.
2. Remove valve receiver (2601320090), valve spring (2601320110) and valve plate (2601310680).

CAUTION: Refer to disassembly of inlet valve assembly (paragraph B).

D. Reassembly of Outlet Valve Assembly

1. Place valve spring (2601320110) in valve receiver (2601320090).
2. Place valve plate (2601310680) in valve receiver (2601320090).
3. Insert the sub-assembled part (assembled in step 1 and 2) into valve seat (2601320081).
4. Tighten the hex nuts.
5. Check the valves to see if they can move freely in their guides and do not pinch or bind between the seat and guard legs.

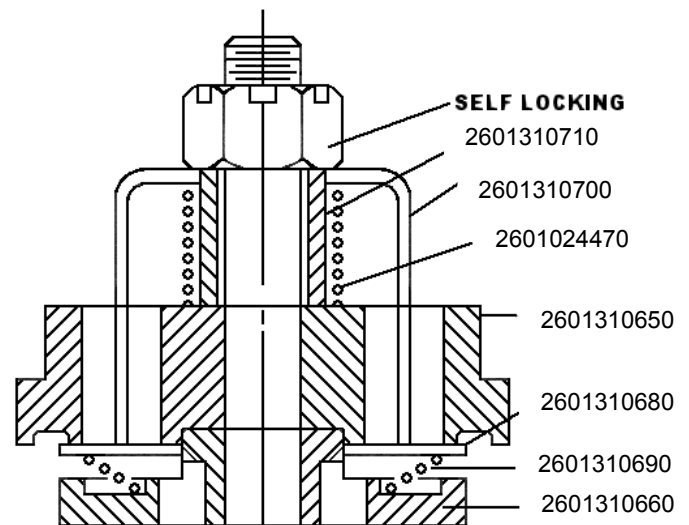
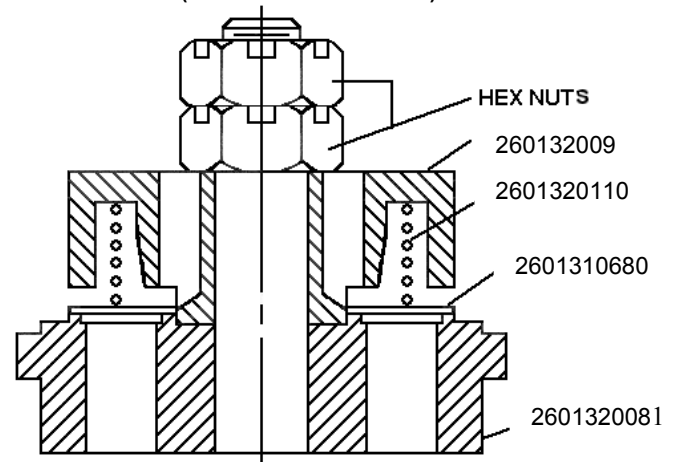
**FIGURE 4 (EXAMPLE SHOWN E-50)****FIGURE 5 (EXAMPLE SHOWN E-50)**

WARNING: Read and understand supplement LV-474 before installing and operating the compressor.

VALVE ASSEMBLY INSTALLATION - E-50 MODEL

(Figures 6 and 7)

1. Install valve assembly gasket (2601024400)
2. Install valve assembly (2601310630).
3. Install valve push cover (2601024420).
4. Install head bolt and tighten evenly and securely.

It is strongly recommended that a Preventative Maintenance Kit & Valve/Gasket Maintenance Kit be kept on hand. In this manner, the valves can be used in turn to keep the compressor always in good condition and a minimum downtime.

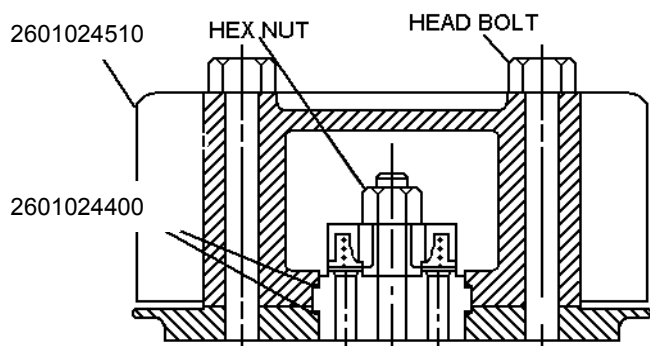

FIGURE 6

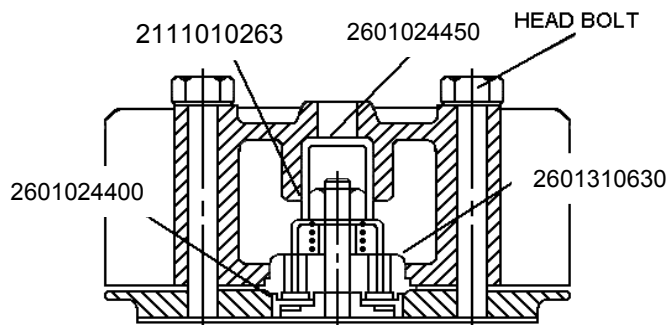

FIGURE 7

PISTON RINGS (Rebuild Kit)

To inspect or replace piston rings as follows:

1. Remove cylinder head.
2. Remove cylinder.
3. Loosen the connecting rod bolts.
4. Push out the piston with piston rings and connecting rod.
5. To remove the old rings, pry them out of their grooves and slide them over the piston. Care should be taken not to damage the piston.
6. Inspect the ring grooves for nicks and carbon deposits. Clean the ring grooves and remove the obstructions, which might prevent the rings from moving freely.

To install new rings on the piston as follows: (Be careful not to damage the piston and rings).

1. Install the oil control ring (2601024990) first. Rotate ring in groove to make sure it is free.
2. Install the Compression ring (2601024970). Make sure the "top" or "R" mark is exactly on top. If not, it might cause excessive oil consumption.
3. Repeat the process with other rings, if any.
4. Assemble connecting rod into the crankshaft. Be sure that the connecting rod and its cap are in original pair and position, since the connecting rod cap and crankshaft pin bushing are selected fitted and are not interchangeable.
5. Check if the ring gaps are in proper positions (Figure 8).

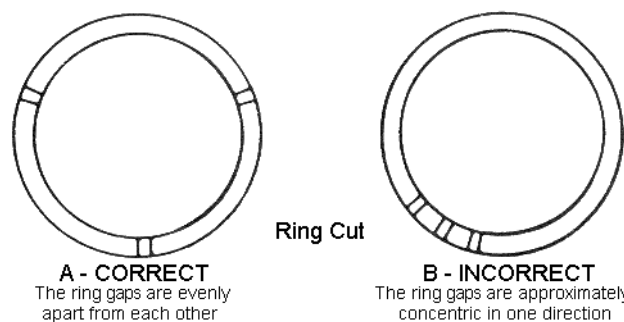

FIGURE 8

WARNING: Read and understand supplement LV-474 before installing and operating the compressor.

• REBUILD KITS

AIR COOLED TWO STAGE MODELS

E-35

E-11			E-23		
PART NO.	CONSISTS OF:		PART NO.	CONSISTS OF:	
CF1250	1 2601021531	Gasket/Cvr Packing Outlet Seal-Front Oil	CF1251	1 2601020300	Gasket-Packing Outlet Valve
	1 2601025680	Packing-Rear Brg. Cvr.		2 2601021531	Gasket/Cvr Packing-Outlet Seal-Front-Oil
	1 2601025590	Packing-Front Brg. Cvr.		1 2601025680	Packing-Rear Bearing Cover
	2 2601021620	Packing-Cylinder & Case		2 2501310010	Plate-Inlet & Outlet
	1 26016212610	Packing-Cylinder/Head		4 2601310180	Plate-Inlet & Outlet Valve
	1 2601021381	Gasket-Packing Cyl&Head		2 2601540050	Filter Air Strainer
	2 7016262050	Ring-Oil Control (2 nd)		1 2601025590	Packing-Front Bearing Cover
	2 7016262030	Ring-Compression (2 nd)		3 2601021620	Packing- Cylinder & Case
	1 2601021910	Ring-Oil Control (2 nd)		1 2601020120	Cylinder & Head Packing
	2 2601021890	Ring-Compression (2 nd)		2 2601021381	Gasket-Packing Cyl & Head
	1 2601320180	Spring-Outlet Valve (2 nd)		2 2601020840	Ring-Oil Control (2 nd)
	1 2601310190	Spring-Inlet Valve (1st)		2 2601020810	Ring-Compression (2 nd)
	2 2601310860	Plate-inlet & Outlet Valve		2 2601021910	Ring-Oil Control (2 nd)
	2 2601310180	Plate-inlet & Outlet Valve		4 2601021890	Ring-Compression (2 nd)
	1 2601540050	Filter Air Strainer		1 2601320390	Spring-Outlet Valve (2 nd)
	1 2601320030	Spring-Outlet Valve 1st		1 2601311470	Spring-Inlet Valve (2 nd)
	1 2601310870	Spring-Inlet Valve (2 nd)		2 2601320030	Spring-Outlet Valve 1st
	24 2102040082	Washer-Copper		2 2601310190	Spring-Inlet Valve 1st
				32 2102040082	Washer- Copper

PART NO.	CONSISTS OF:	
CF1306	PREVENTATIVE MAINTENANCE KIT INCLUDES:	
1	70110HC1-66111 Element- Air Strainer	
CF1307	VALVE/GASKET MAINT KIT INCLUDES:	
4	7015231030	Plate- IO Valve (1 st)
2	7015232030	Plate- IO Valve (2 nd)
2	7015232070	Spring-Valve Plate (2 nd)
1	7015231120	Packing(Gasket)Valve Seat
4	7015231070	Spring-Valve Plate (1 st)
1	7015211622	Gasket-Cyl & Valve Seat
1	7015211612	Gasket-Packing Cyl Head
CF1308	REBUILD KIT E-35 INCLUDES:	
1	7015251610	Packing, Cyl-Crankcase
1	7015257950	Packing-Front Cvr Gasket
2	7015261030	Ring-Compression (1 st)
1	7015261050	Ring-Oil Control (1 st)
1	7015261080	Bushing-Piston (1 st)
1	7015262080	Bushing-Piston Pin
2	7015261090	Crankpin Metal
3	7015262030	Ring-Compression(2 nd)
1	7015262050	Ring-Oil Control (2 nd)
1	7015257960	Packing-Rear Cvr Gasket
1	7012757080	Seal-Front/Oil
6	2102040082	Washer- Copper

E-57		E-50		E-71		E-15	
PART NO.	CONSISTS OF:	PART NO.	CONSISTS OF:	PART NO.	CONSISTS OF:	PART NO.	CONSISTS OF:
CF1291	KIT-PREVENTATIVE MAINTENANCE B-2B COMPRESSOR INCLUDES	CF1315	KIT PREVENTATIVE MAINTENANCE INCLUDES:	CF1315	PREVENTATIVE MAINTENANCE KIT INCLUDES:	CF1315	PREVENTATIVE MAINTENANCE KIT INCLUDES:
1	2601540300 Air Filter Element	2	2601540410 Air Strainer Filter	2	2601540410 Air Strainer Filter	2	2601540410 Air Strainer Filter
CF1292	B-2 VALVE/GASKET MAINT KIT INCLUDES:	CF1253	E50 GASKET/VALVE MAINT KIT INCLUDES:	CF1255	E71 GASKET/VALVE MAINT KIT INCLUDES:	CF1257	E15 GASKET/VALVE MAINT KIT INCLUDES:
4	2601310460 Valve Plate/Inlet & Outlet	3	2601024331 Packing- Cylinder Head	2	2601310940 Inlet Valve Spring	1	2601026130 Cyl Head Gasket 2 nd Stage
2	2601310560 Inlet & Outlet Valve Plate	6	2601024400 Inlet&Outlet Valv Gasket E71	1	2601024331 Packing- Cylinder Head	2	2601030530 Cyl Head Gasket 1st Stage
4	7015331072 Spring-Valve Plate 2 nd	3	2601320110 Spring-Outlet Valve	2	2601026130 Packing-Cylinder & Head	2	2601026190 Inlet&Outlet Valv Seat Gaskt
2	7015332072 Spring-Valve Plate 2 nd	3	2601310690 Spring-Inlet Valve	2	2601024400 Inlet&Outlet Val Gaskt E71	4	2601027620 Inlet&Outlet Valv Seat Gaskt
1	2601310500 Packing/Valve Seat (Gasket)	6	5012331030 Plate-Inlet & Outlet Valve	4	2601026190 Inlet & Outlet Valve Seat	1	2601320220 Outlet Valv Spring 2 nd Stage
1	2601022880 Packing, Cylinder Head			1	2601320110 Spring-Outlet Valve	6	2601320376 Outlet Valv Spring 1st Stage
1	2601310510 Gasket-Packing Cyl & Head			2	2601320220 Outlet Valve Spring	1	2601310940 Inlet Valve Spring 2 nd Stage
				1	2601310690 Spring-Inlet Valve	2	2601311180 Inlet Valv Spring 1st Stage
				2	5012331030 Plate-Inlet & Outlet Valve	1	2501320120 2 nd Stage Outlet Valve Plate
				4	7012431030 Inlet & Outlet Valve Plate	2	2501310130 1st Stage Inlet Valve Plate
				3	2601024331 Packing-Cylinder Head	4	2601491240 Manifold Gasket
				6	2601024400 Inlet&Outlet Val Gaskt E71	2	2501320081 1 st Stage Outlet Valve Plate
				3	2601320110 Spring-Outlet Valve	1	2501310100 2 nd Stage Inlet Valve Plate
				3	2601310690 Spring-Outlet Valve		
				6	5012331030 Plate-Inlet & Outlet Valve		
CF1293	B-2 REBUILD KIT INCLUDES:	CF1254	E50 REBUILD KIT INCLUDES:	CF1256	E71 REBUILD KIT INCLUDES:	CF1258	E15 REBUILD KIT INCLUDES:
1	2601023270 Gasket Front Cover	1	2110090036 Needle Bearing	3	2601026310 Packing-Cyl & Case	1	2601030820 Packing-Frt Bearing Cvr
2	2601026840 Compression Ring	3	2601024570 Cyl/Head Case Packing	1	7017462081 Bushing-Con. Rod Pistrn Pin	3	2601030630 Cylinder/Case Packing
2	2601026860 Oil Control Ring	6	2601025040 Bearing-Connecting Rod	2	2501020130 Con. Rod Pistrn pin bush	6	2601027780 Connecting Rod Crank Pin
3	2601023520 Compression Ring (2 nd)	2	2601025030 Bushg- Conn. Rod Pistrn	4	2601026860 Oil Control Ring	2	2601026860 Oil Control Ring
1	2601023540 Oil Control Ring (2 nd)	1	2601021910 Ring-Oil Control (2 nd)	4	2601026840 Compression Ring	3	2601026840 Compression Ring
1	2601023560 Bushing-Piston Pin (1 st)	3	2601021890 Ring-Compression (2 nd)	1	2601026520 Packing- Frt Bush Cvr	4	2601027740 Ring-Oil Control (1 st)
1	7015362081 Bushing-Piston Pin (2 nd)	1	2601024750 Frt. Brg Cvr. Packing	1	2601029860 Front Oil Seal	4	2601027730 Ring-Compression (1 st)
4	2601023400 Crank Pin Metal (Bearing)	1	7012357080 Seal-Front Oil	6	2601023900 Conn Rod Bearing	1	2601027860 Connecting Rod Assy.
1	2601023130 Packing (Gasket) Cylinder	1	2601028600 Bushing-Piston Pin	2	2601029810 Packing-Rear Brg Cvr	1	2601029860 Front Oil Seal
1	7012357080 Seal-Front Oil	1	701308A1-57070-512 Rear Brg Cvr Gasket	2	7013457070-01 Gaskt-Reat Brg Cvr	1	2110090016 Needle Bearing (2 nd)
1	2601023330 Gasket-Packing Rear Cover	4	2601024970 Compr. Ring, E71 E50 ES30	2	701310A1-57070-2 Shim, Bearing Cvr Gaskt	2	2601029810 Packing-Rear Brg Cvr
26	2102040074 Rear Brg Cvr Bolt Washer	4	2601024990 Oil Contrl Ring,E71 E50 ES30	3	2601024970 Compr. Ring, E71 E50 ES30	24	92521191200 Washer-Cover
		34	2102040074 Rear Brg Cvr Bolt Wshr	2	2601024990 Oil Contrl Ring,E71 E50 ES30	1	7017562080 Bush-Conn. Rod Pistrn Pin
				2	2102040074 Rear Brg Cvr Bolt Wshr	2	7013457070-01 Gasket, Rear Brg Cvr
						2	701310A1-57070-2 Shim,Bearing Cvr Gaskt

* **WARNING** – THESE ITEMS INTERCHANGE WITH PARTS ON SERIAL #3020000 & HIGHER ONLY. CONTACT FACTORY FOR EARLIER SERIES.

** USE WITH SERIAL #A311XXXX AND LATER. 70135-11610 REPLACES 70125-11610

*** USE WITH SERIAL #A409XXXX AND LATER

**** USE FOR UNITS PRIOR TO SERIAL #A409XXXX

RING SETS & GASKET SETS

TWO-STAGE

MODEL	PART NO.	DESCRIPTION	QUANTITY REQ'D
E11	CF1266	Ring set (LP)	1
	CF1267	Ring set (HP)	1
	CF1283	Gasket set	1
E23	CF1268	Ring set (LP)	2
	CF1269	Ring set (HP)	1
	CF1284	Gasket set	1
E35	CF1303	Ring set(LP)	1
	CF1304	Ring set(HP)	1
	CF1305	Gasket set	1
E50	CF1270	Ring set(LP)	2
	CF1271	Ring set(HP)	1
	CF1285	Gasket set	1
E57	CF1288	Ring set(LP)	1
	CF1289	Ring set(HP)	1
	CF1290	Gasket set	1
E71	CF1272	Ring set(LP)	2
	CF1273	Ring set(HP)	1
	CF1286	Gasket set	1
E15	CF1274	Ring set(LP)	2
	CF1275	Ring set(HP)	1
	CF1287	Gasket set	1
	*CF1313	*Gasket set	1

* USE WITH SERIAL #A311XXXX AND LATER

INSPECTION & MAINTENANCE OF E-57 VALVE ASSEMBLY

INSTRUCTION FOR E-57 COMPRESSOR MODEL HEAD VALVE ASSEMBLY INSPECTION AND MAINTENANCE.

Model E-57 valve assembly inspection and maintenance instruction.

1. Inspect valve assemblies every 1000 hours of operation or as necessary to maintain efficient operation.
2. Turn off power, red tag power supply switch (caution: Maintenance in progress – DO NOT START). Drain all air pressure from system before starting work.
3. Disconnect air piping from head.

Remove valve package.

- A1. Loosen and remove head bolts. On constant run models, remove upper tubing from unloader cylinder.
- A2. Remove cylinder head to expose valve assembly.
- A3. Remove valve assembly, head to valve package gasket and valve package to cylinder gasket. Use new gaskets in re-assembly. Note conditions of cylinders, clean out any foreign material and cover with clean shop cloth while open.
- A4. Refer to parts breakdown for description of valve package.
- A5. Secure valve assembly package, loosen and remove socket head bolts to separate the upper and lower valve seats. This will expose the valve springs and valve plates.
CAUTION: Do not interchange upper and lower valve seats
- A6. Thoroughly clean and wash all valve seats and parts with a suitable non-flammable cleaning fluid.
CAUTION: Use care to not scratch or deform valve parts in the cleaning.
- A7. Carefully inspect the valve seats, plates and springs for dents, cracks, wear, and any reason to prevent proper and efficient operation.
- A8. Replace all parts not in proper condition.

Assemble valve assembly package.

- B1. Secure lower valve plate in flat position with spring slots "up".
- B2. Refer to parts breakdown for valve package breakdown.
- B3. Place valve springs and valve plates in proper positions over slots in seat. Use tag wire or string for tie to hold in position for completing assembly.
- B4. Secure upper valve seat in flat position with spring slots up
- B5. Use new valve seat gasket.
- B6. Place valve seat gasket in position on lower valve plate.
- B7. Place upper valve seat with valve springs and plates tied in position on top of lower valve seat with new valve seat gasket in place between the two seats.
- B8. Start center and then two end valve plates socket head bolts, tighten finger tight being careful not to damage seat gasket, use socket head wrench to torque the three bolts uniformly to secure the top valve seat to the lower valve seat using care to avoid damage to the gasket, and valve springs and plates from moving out of position.
- B9. Remove ties to free valve springs and plates
- B10. Check to be sure valve springs and valve plates are in proper position and the plates are free to flex when manually touched with blunt instrument.

Assemble valve assembly package into compressor.

- C1. Use new gaskets, valve package to cylinder and cylinder head to valve package. Select gaskets by part numbers from parts breakdown.
- C2. Remove shop cloth to expose open cylinder bores. Remove any foreign matter from cylinder bores and top of cylinder.
- C3. Place gasket on top of cylinder, place and align valve package, place gasket on top of valve package and align holes for head bolts.
- C4. Place clean head on top of valve package with gasket and align with cylinder bolt holes.
- C5. Insert cylinder head bolts using care to avoid damage to the gaskets, start each bolt threading evenly to contact head surfaces.
- C6. Torque head bolts equally, follow torque specifications on page 20.
- C7. Attach and tighten copper tubing of constant running compressors.
- C8. Assemble and tighten discharge tubing.
- C9. Check oil level in crankcase
- C10. Close and tighten valve or the connections used to drain air pressure from system.
- C11. Remove all tools and make area safe to start compressor.
- C12. Turn on power at main switch and inspect to see that unit is operating properly.
- C13. Stay with unit for normal pump up to cut out pressure.
- C14. If unit has performed through a running cycle properly put on line for duties and remove red tag from power supply switch.
- C15. Make entry in equipment maintenance log.

VALVE PLATES DESIGNS FOR E-57 COMPRESSOR

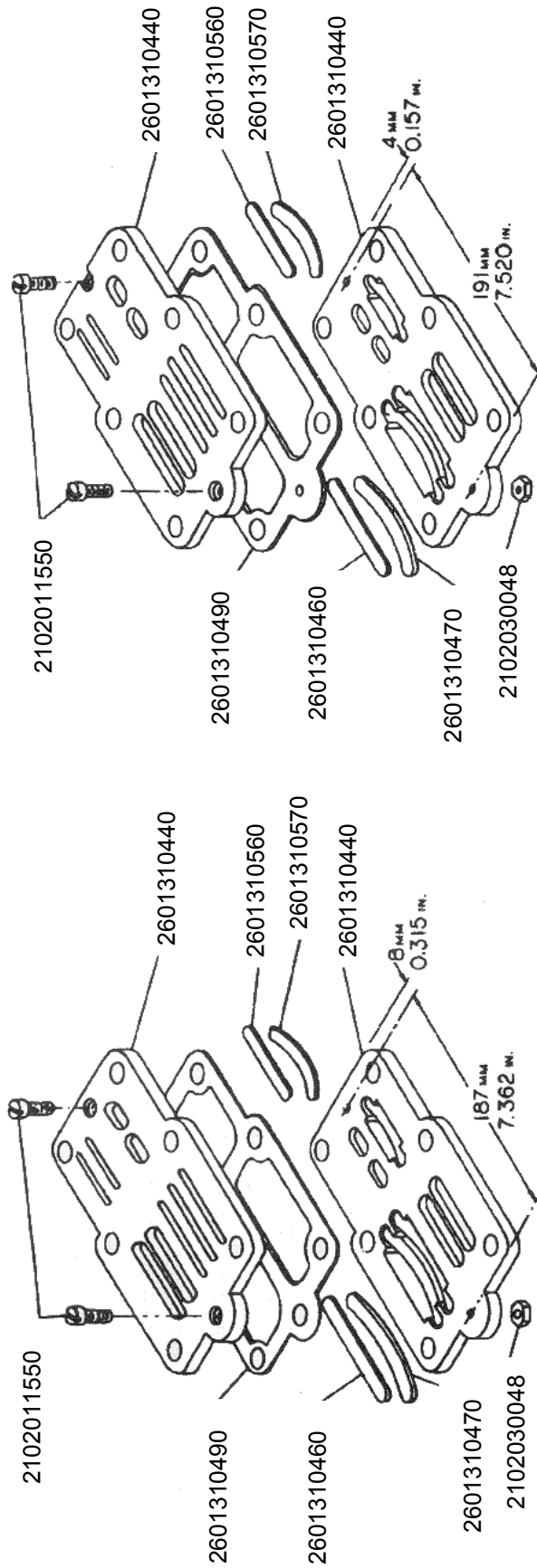

FIG. 1

SERIAL NUMBER 6107030
THROUGH 6116445

FIG. 2

SERIAL NUMBER 7010603
THROUGH 7043734

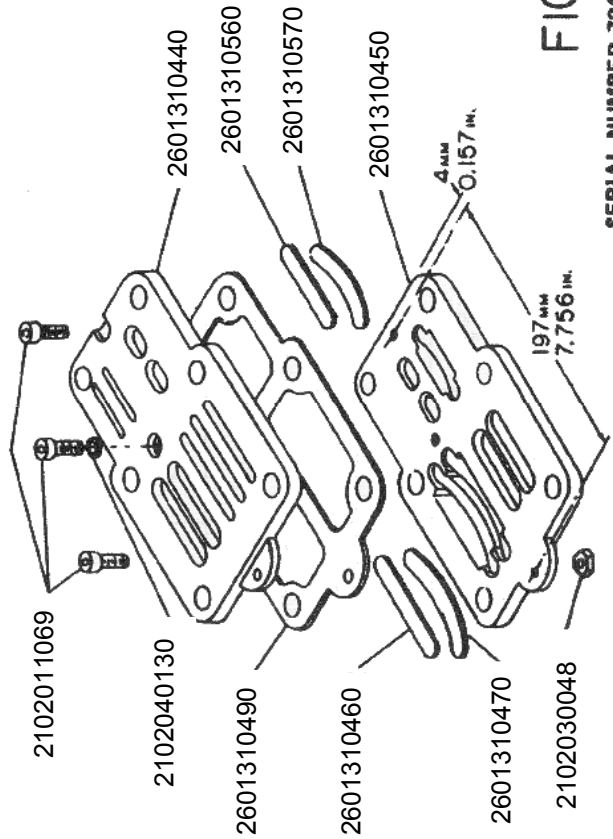

FIG. 4

SERIAL NUMBER 7043735
AND LATER

BOLT TORQUES FOR CHALLENGE AIR COMPRESSORS

	HEAD BOLTS		CYLINDER-CASE		ROD BOLTS		FRONT COVER		REAR COVER		INLET & OUTLET VALVE PUSH COVERS	
	SIZE BOLT	TORQUE CM-FT.	SIZE BOLT	TORQUE CM-FT.	SIZE BOLT	TORQUE CM-FT.	SIZE BOLT	TORQUE CM-FT.	SIZE BOLT	TORQUE CM-FT.	SIZE BOLT	TORQUE CM-FT.
E11	M8-1.25	200-14.5	M8-1.25	200-14.5	M8-1.25	180-13.0	M8-1.25	180-13.0	M8-1.25	180-13.0		
E23	M8-1.25	200-14.5	M8-1.25	200-14.5	M8-1.25	180-13.0	M8-1.25	180-13.0	M8-1.25	180-13.0		
E35	M8-1.25	200-14.5	M8-1.25	200-14.5	M8-1.25	180-13.0	M8-1.25	180-13.0	M8-1.25	300-21.7		
E50	M10-1.5	300-21.7	M10-1.5	280-20.35	M8-1.5	280-20.25	M8-1.5	280-20.25	M10-1.5	280-20.25	M8-1.25	225-16.3
E57	M10-1.5	320-23.1	M10-1.5	280-20.25	M8-1.25	280-20.25	M10-1.5	300-21.7	M8-1.25	300-21.7		
E71	M10-1.5	320-23.1	M10-1.5	280-20.25	M8-1.5	300-21.7	M8-1.5	300-21.7	M10-1.5	280-20.25	M8-1.25	225-16.3
E15	M10-1.5	320-23.1	M10-1.75	350-25.3	M10-1.5	300-23.1	M10-1.5	320-23.1	M10-1.5	280-20.25	L M10-1.5 H M8-1.25	320-23.1 225-16.3

BOLT TORQUES

MODEL NO.	FLYWHEEL BOLTS		FAN BOLTS	
	TORQUE FT.-LBS.	TORQUE IN.-LBS.	TORQUE FT.-LBS.	TORQUE IN.-LBS.
E11 E35	12	144	-	-
E57	23	276	-	-
E23	12	144	-	-
E50	40	480	-	-
E71	45	540	24	288
E15	50	600	24	288

OIL CAPACITIES

MODEL NUMBER	HORSEPOWER	MIN RPM	OIL CAPACITY
E23	2 – 3	500	1¾ PINTS
E50	5	500	1½ QUARTS
E11	1	500	1¼ PINTS
E35	3 – 5	500	2½ PINTS
E57	5 – 7½	500	2 QUARTS
E71	10	500	2½ QUARTS
E15	15	500	5 QUARTS

TROUBLESHOOTING

	SYMPTOMS	CAUSES	REMEDIES
WHEN COMPRESSOR CAN BE STARTED	Flywheel rotation in wrong direction	Incorrect connection of motor terminal	Re-arrange terminal connection.
	Overheating of bearings	1. Insufficient lubrication. 2. Bad lubrication system. 3. Crankshaft bearings too tight.	1. Add lubrication oil. 2. Remove and examine the system. 3. Readjust load on bearings.
	Flywheel rotation slows down	1. Heavy lubrication oil. 2. Drop in voltage. 3. Belts slipping.	1. Refill with lighter lubrication oil. 2. Contact power company or install a transformer. 3. Tighten belts
	Severe vibration	Bent crankshaft	Remove & Replace
	Abnormal noise	1. Loose valve assembly. 2. Piston hits cylinder cover. 3. Worn connecting rod bearing.	1. Tighten valve bolt and lock nut. 2. Check piston & rod assembly for excessive wear. 3. Replace bearing.
	Pressure cannot be built up or only up to a certain extent	1. Worn valve plate. 2. Valve springs have lost their temper. 3. Dirt on the valve plate. 4. Leaks from safety valve. 5. Leaks from bolt holes. 6. Uneven valve seat surface. 7. Excessive blow by on piston rings. 8. Bad packing (gasket too thick). 9. Excessive air leaks.	1. Repair or replace valve plate. 2. Replace valve springs. 3. Remove and clean it. 4. Repair or replace safety valve. 5. Tighten the nuts even with packing. 6. Remove and lap the surface. 7. Replace with new ones 8. Replace packing (gasket). 9. Eliminate air leaks.
	Inaccuracy of pressure gauge	Pressure gauge damaged.	Replace.
	Excessive oil consumption	1. Worn piston ring 2. Worn piston. 3. Worn cylinder.	1. Replace. 2. Replace. 3. Replace.
	Slipping of belts	1. Working pressure too high. 2. Improper belt tension. 3. Worn belt.	1. Lower working pressure. 2. Adjust belt tension. 3. Replace with new ones.
	Overheating of electric motors	1. Overloading of motor due to excessive working pressure (higher than stipulated pressure). 2. Burnt piston. 3. Burnt bearing metals. 4. Drop of voltage.	1. Lower working pressure. 2. Rebuild compressor. 3. Rebuild compressor. 4. Contact power company or install a transformer
WHEN COMPRESSOR CANNOT BE STARTED	Unit will not start	1. Breakdown of electric current. 2. Line failure. 3. Malfunction of motor	1. Contact power company. 2. Examine the line. Replace with new wiring. 3. Contact motor manufacturer.
	Fuse tends to blow	1. Incorrect size. 2. Wrong connections 3. Overloading of motor. 4. Overloading of motor due to leaks of outlet valve. 5. Crankshaft too tight.	1. Replace with correct size. 2. Change connections. 3. Eliminate the loading. 4. Remove and repair outlet valve. 5. Remove crankshaft and examine it for cause.

FS CURTIS

CUSTOMER SERVICE (314) 383-1300

RECOMMENDED STATEMENT ON DRYERS AND FILTERS

Liquid water occurs naturally in air lines as a result of compression. Moisture vapor in ambient air is concentrated when pressurized and condenses when cooled in downstream air piping.

Compressed air dryers reduce water vapor concentration and prevent liquid water formation in compressed air lines. Dryers are necessary companion to air filters, aftercoolers, and automatic tank drains for improving the productivity of compressed air systems.

Water and water vapor removal increases the efficiency of air operated equipment, reduces contamination and rusting, increases service life of pneumatic equipment and tools, prevents air line freeze ups, and reduces product rejects. The use of dryer's filters is recommended when this moisture related problems are reported to our factory or distributor service departments.

Troubleshooting guide

Symptom: Liquid water present in compressed air lines.

Problem: Water vapor condensation from cooling and compression occurs naturally

Solution: Remove the water vapor from compressed air prior to distribution through the air system. Check operation of after-cooler and moisture separator. Install a compressed air dryer sized for the flow and dryness level required.

(Note: filters may also be required to remove particles, liquid oil aerosols, or for oil vapor removal. Change cartridges as recommended by filter manufacturer.)

Check all drain traps routinely to insure their proper operation. Maintain them regularly.

COMPRESSOR PUMP-UP TIME

TWO STAGE

H.P. Size	Compressor Model No.	R.P.M.	Piston Displ. C.F.M.	Tank size		Approx. Time Required To Pump From:	
				Size (in)	Gal	0 to 175 PSIG Min. – Sec.	145 to 175 PSIG Min. – Sec.
3	3VT6	947	10.66	20 x 50	60	12' – 24"	2' – 8"
5	5E23VT6	1000	11.3	20 x 50	60	11' – 47"	2' – 1"
5	5E1HT6	1100	15.81	20 x 50	60	7' – 46"	1' – 20"
5	5E1VT6	1100	15.81	20 x 50	60	7' – 46"	1' – 20"
5	5E1HT8	1100	15.81	20 x 48	80	10' – 21"	1' – 46"
5	5E1VT8	1100	15.81	20 x 48	80	10' – 21"	1' – 46"
5	5HT6	968	20.58	20 x 50	60	5' – 56"	1' – 1"
5	5VT6	968	20.58	20 x 50	60	5' – 56"	1' – 1"
5	5HT8	968	20.58	20 x 66	80	7' – 54"	1' – 21"
5	5VT8	968	20.58	20 x 48	80	7' – 54"	1' – 21"
5	5E2HT6	900	21.47	20 x 50	60	5' – 25"	0' – 56"
5	5E2VT6	900	21.47	20 x 50	60	5' – 25"	0' – 56"
5	5E2HT8	900	21.47	20 x 66	80	7' – 14"	1' – 14"
5	5E2VT8	900	21.47	20 x 48	80	7' – 14"	1' – 14"
7 1/2	7E2HT8	1100	26.24	20 x 66	80	6' – 16"	1' – 05"
7 1/2	7E2VT8	1100	26.24	24 x 48	80	6' – 16"	1' – 05"
7 1/2	7HT8	764	29.57	20 x 66	80	5' – 22"	0' – 55"
10	10HT8	977	37.81	20 x 66	80	4' – 11"	0' – 43"
10	10HT12	977	37.81	24 x 70	120	6' – 17"	1' – 5"
10	10VT12	977	37.81	30 x 47	120	6' – 17"	1' – 5"
15	15HT12	855	54.55	24 x 70	120	4' – 28"	0' – 46"

TWO STAGE GASOLINE ENGINE DRIVEN

H.P. Size	Compressor Model No.	R.P.M.	Piston Displ. C.F.M.	Tank size		Approx. Time Required To Pump From:	
				Size (in)	Gal	0 to 175 PSIG Min. – Sec.	145 to 175 PSIG Min. – Sec.
10	10E2GT3	910	21.7	16 x 41	30	2' – 42"	0' – 28"
10	10GT3	950	20.2	16 x 41	30	3' – 1"	0' – 31"
10	10GT6	950	20.2	20 x 50	60	6' – 3"	1' – 2"
13	13E2GT3K	910	21.7	16 x 41	30	2' – 42"	0' – 28"
13	13GT3K	950	20.2	16 x 41	30	3' – 1"	0' – 31"
13	13GTGK	950	20.2	20 x 50	60	6' – 3"	1' – 2"
13	13E2GT3HE	910	21.7	16 x 41	30	2' – 42"	0' – 28"

NOTES



CA SERIES

E57A COMPRESSOR PUMP PARTS LIST

LOT NUMBER:

RECORD MODEL & SERIAL NUMBER BELOW:

MODEL: _____

SERIAL: _____

Curtis Toledo Inc
1905 Kienlen Avenue, St Louis, Missouri 63133
Tel: (314) 383-1300 Fax: (314) 381-1439
www.fscurtis.com

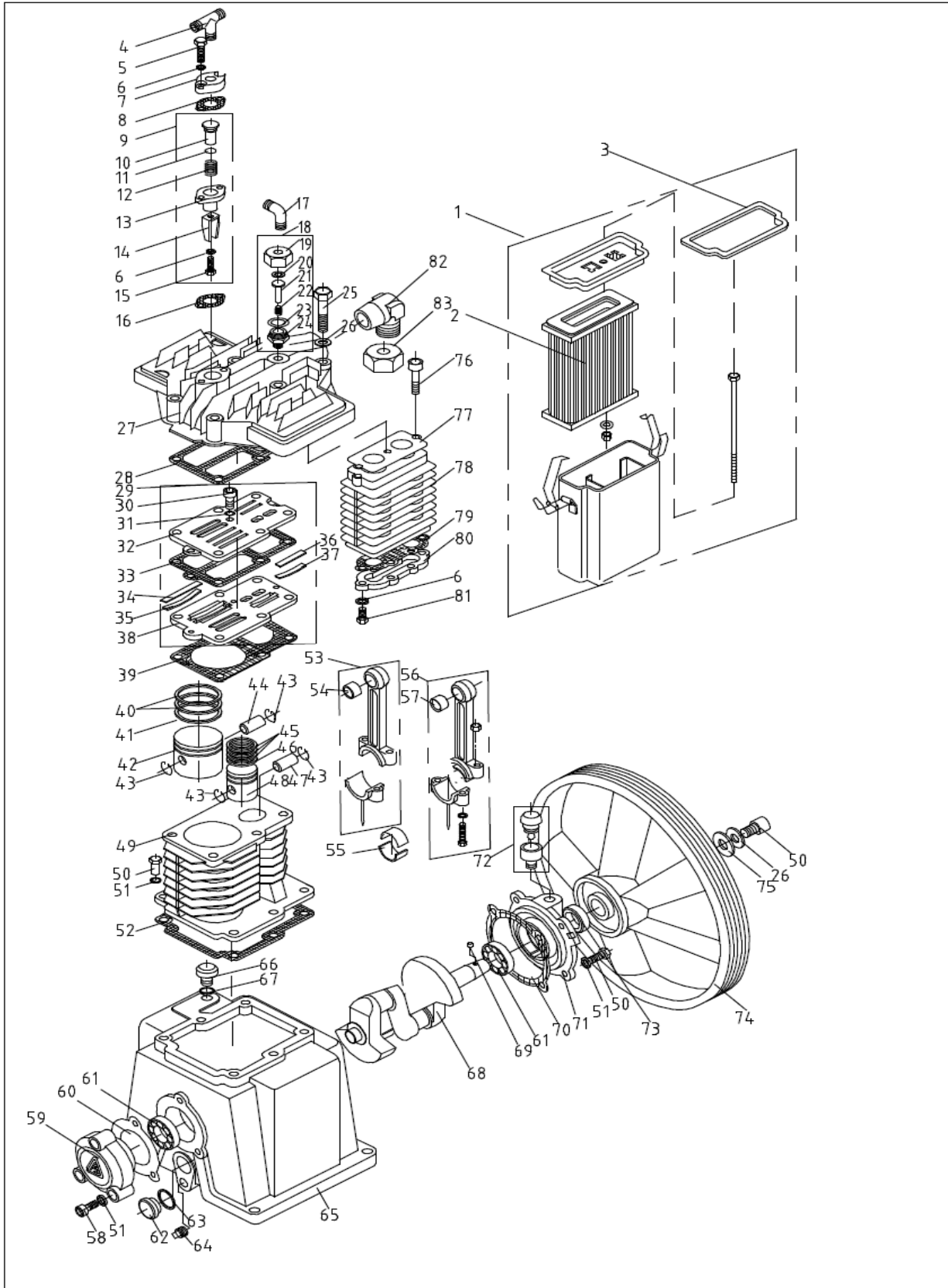

ITEM	DESCRIPTION	QTY	PART NUMBER
AIR STRAINER			
1	Air Strainer Assembly	1	2601540262
2	Air Strainer Element	1	2601540300
3	Air Strainer Cover Gasket	1	2601540330
UNLOADER			
4	Unloader Copper Tee	1	2101090006
5	Unloader Push Cover Bolt; M6 x L25, Gr 8.8 (1st)	2	2102011103
6	Unloader Push Cover Spring Washer; M6 (1st)	7	2102040134
7	Unloader Push Cover (1st)	1	2601022970
8	Unolader Push Cover Gasket (1st)	1	2601023030
9	Unloader Assembly (1st)	1	2601022921
10	Unloader Piston (1st)	1	2601022952
11	Viton O-Ring Unloader (1st)	1	2111010101
12	Unloader Spring (1st)	1	2601022961
13	Unloader Cylinder (1st)	1	2601022941
14	Unloading Fork (1st)	1	2601310480
15	Unloader Bolt; M6 x L16 Gr 8.8 (1st)	1	2102011095
16	Unloader Gasket (1st)	1	2601035400
17	Unloading Elbow	1	2688360780
18	Unloader Assembly (2nd)	1	2601023051
19	Unloader Push Cover (2nd)	1	2601022291
20	Viton O-Ring Unloader (2nd)	1	2111010092
21	Unloader Piston (2nd)	1	2601023072
22	Unloader Spring (2nd)	1	2601022281
23	Unloader Copper Washer (2nd)	1	2601022340
24	Unloader Body (2nd)	1	2601022271
CYLINDER HEAD			
25	Cylinder Head Bolt; M10 x L85, Gr 8.8	6	2102010337
26	Cylinder Head Spring Washer; M10	7	2102040140
27	Cylinder Head	1	2601022860
28	Cylinder Head - Valve Seat Gasket	1	2601022880
VALVE ASSEMBLY			
29	Valve Plate Assembly	1	2601310420
30	Valve Seat Bolt; M5 x L12, Gr 8.8	3	2102011071
31	Valve Seat Bolt Spring Washer; M5	3	2102030049
32	Valve Seat (Upper)	1	2601310440
33	Valve Seat Gasket	1	2601310500
34	Valve Plate (1st)	4	2601310460
35	Valve Plate Spring (1st)	4	2601310470
36	Valve Plate (2nd)	2	2601310560
37	Valve Plate Spring (2nd)	2	2601310570
38	Valve Seat (Bottom)	1	2601310450
39	Cylinder-Valve Seat Gasket	1	2601310510

ITEM	DESCRIPTION	QTY	PART NUMBER
CYLINDER, PISTON & RING			
40	Compression Ring (1st)	2	2601026840
41	Oil Control Ring (1st)	2	2601026860
42	Piston (1st)	1	2601023361
43	Piston Snap Ring	4	2601023370
44	Piston Pin (1st)	1	2601023420
45	Compression Ring (2nd)	3	2601023520
46	Oil Control Ring (2nd)	1	2601023540
47	Piston Pin (2nd)	1	2601023570
48	Piston (2nd)	1	2601023500
49	Cylinder	1	2601023100
50	Cylinder Bolt; M10 x L30, Gr 8.8	11	2102010276
51	Cylinder Copper Washer; M10	13	2102040074
52	Cylinder Crankcase Gasket	1	2601023130
CONNECTING ROD			
53	Connecting Rod Assembly (1st)	1	2601023600
54	Connecting Rod - Piston Pin Bushing (1st)	1	2601023391
55	Connecting Rod Crank Pin Metal (1st)	4	2601023400
56	Connecting Rod Assembly (2nd)	1	2601023600
57	Connecting Rod - Piston Pin Needle Bearing (2nd)	1	2110090039
CRANKCASE & CRANKSHAFT			
58	Rear Bearing Cover Bolt; M8 x L30, Gr 8.8	3	2102011146
59	Rear Bearing Cover	1	2601023281
60	Rear Bearing Cover Gasket	1	2601023330
61	Front & Rear Bearing	2	2110020104
62	Plug-in Oil Level Glass	1	2601020740
63	Oil Level Glass Gasket	1	2601020770
64	Crankcase Oil Plug (Special non-standard)	1	2601023080
65	Crankcase	1	2601023200
66	Oil Fill Cap	1	2601024910
67	O-ring (Oil Fill Cap)	1	2111010013
68	Crankshaft	1	2601023150
69	V-Pulley Pin	1	2601024660
70	Front Bearing Cover Gasket	1	2601023270
71	Front Bearing Cover	1	2601023220
72	Breather Assembly	1	2601026681
73	Front Oil Seal	1	2601024870
74	Compressor Pulley	1	2601230941
75	Compressor Pulley Thrust Washer	1	2601237360

ITEM	DESCRIPTION	QTY	PART NUMBER
INTER-COOLER			
76	Inter-Cooler Bolt (Upper)	3	2102011161
77	Inter-Cooler Body Gasket (Upper)	1	2601510190
78	Inter-Cooler Body	1	2601510140
79	Inter-Cooler Body Gasket (Bottom)	1	2601510220
80	Inter-Cooler Bottom Cover	1	2601510161
81	Inter-Cooler Bolt (Bottom)	4	2102010123
82	Discharge Elbow	1	2601490971
83	Discharge Elbow Nut	1	2688360290

NOTES



CA SERIES

E71 COMPRESSOR PUMP PARTS LIST

LOT NUMBER:

RECORD MODEL & SERIAL NUMBER BELOW:

MODEL: _____

SERIAL: _____

Curtis Toledo Inc
1905 Kienlen Avenue, St Louis, Missouri 63133
Tel: (314) 383-1300 Fax: (314) 381-1439
www.fscurtis.com

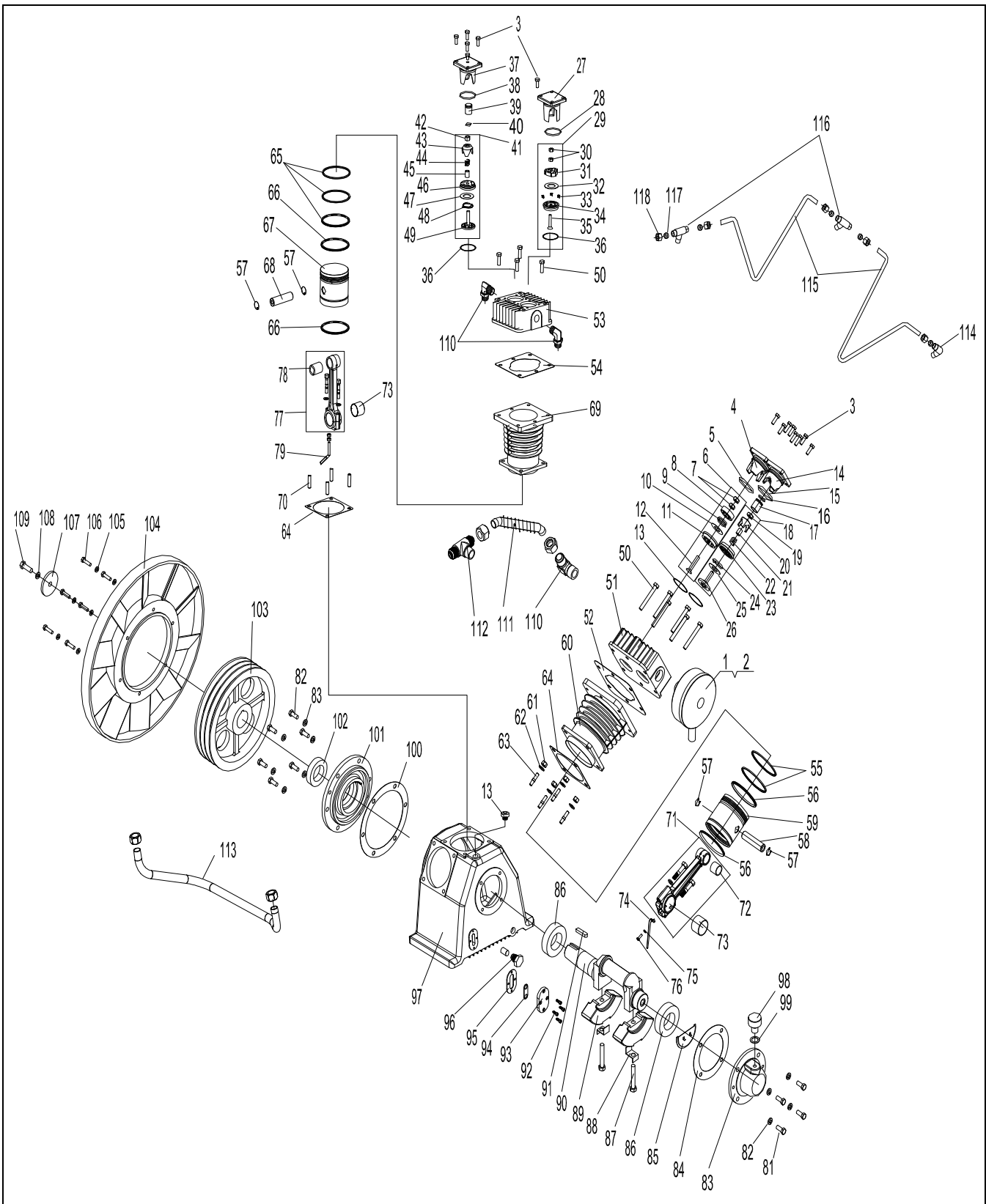

ITEM	DESCRIPTION	QTY	PART NUMBER
AIR STRAINER			
1	Air Strainer Assembly	2	2601540560
2	Air Strainer Element (Not Shown)	2	2601540410
VALVE & UNLOADERS			
3	Outlet Valve Push Cover Bolt; M8 x L25, Gr 8.8	16	2102010189
4	Outlet Valve Push Cover (1st)	2	2601026250
5	Viton O-ring G 55 (Outlet Valve-1st)	2	2111010267
6	Outlet Valve Assembly (1st)	2	2601320190
7	Nut; M8 (Outlet Valve-1st)	4	2102030064
8	Outlet Valve Receiver (1st)	2	2601320210
9	Outlet Valve Spring (1st)	2	2601320220
10	Outlet Valve Plate (1st)	2	2501310100
11	Outlet Valve Seat (1st)	2	2601320202
12	Outlet Valve Bolt; M10 x L50, Gr 8.8 (1st)	2	2102011755
13	Inlet & Outlet Valve Gasket (1st)	4	2601026190
14	Inlet Valve Push Cover (1st)	2	2601026210
15	O-ring G 55 (Inlet Valve-1st)	2	2111010224
16	Viton O-ring P 21 (Unloader-1st)	2	2111010105
17	Unloader Piston (1st)	2	2601026230
18	Inlet Valve Assembly-1st	2	2601310880
19	Locknut; M10 (Inlet Valve-1st)	2	CALL FACTORY
20	Inlet Valve Unloader Fork (1st)	2	2601310950
21	Inlet Valve Unloader Fork Guide (1st)	2	2601310960
22	Unloader Spring (1st)	2	2601026240
23	Inlet Valve Seat (1st)	2	2601310901
24	Inlet Valve Plate (1st)	2	2501310100
25	Inlet Valve Spring (1st)	2	2601310940
26	Inlet Valve Receiver (1st)	2	2601310910
27	Outlet Valve Push Cover (2nd)	1	2601024510
28	Viton O-ring G 40 (Outlet Valve-2nd)	1	2111010263
29	Outlet Valve Assembly (2nd)	1	2601320070
30	Nut; M8 (Outlet Valve-2nd)	1	SEE FACTORY
31	Outlet Valve Receiver (2nd)	1	2601320090
32	Outlet Valve Plate (2nd)	3	2501310050
33	Outlet Valve Spring (2nd)	1	2601320110
34	Outlet Valve Seat (2nd)	1	2601320081
35	Outlet Valve Bolt (2nd)	1	2601320120
36	Inlet & Outlet Valve Gasket (2nd)	2	2601024400
37	Inlet Valve Push Cover (2nd)	1	2601024420
38	Viton O-ring G 40 (Inlet Valve-2nd)	1	2111010263
39	Unloader Piston (2nd)	1	2601024450
40	Viton O-ring P 20 (Unloader-2nd)	1	2111010104

ITEM	DESCRIPTION	QTY	PART NUMBER
41	Inlet Valve Assembly (2nd)	1	2601311230
42	Locknut; M8 (Inlet Valve-2nd)	2	CALL FACTORY
43	Inlet Valve Unloader Fork (2nd)	1	2601310700
44	Unloader Spring (2nd)	1	2601024470
45	Inlet Valve Unloader Fork Guide (2nd)	1	2601310710
46	Inlet Valve Seat (2nd)	1	2601310650
47	Inlet Valve Plate (2nd)	1	2501310050
48	Inlet Valve Spring (2nd)	1	2601310690
49	Inlet Valve Receiver (2nd)	1	2601311250
50	Cylinder Head Bolt (1st); M10 x L80, Gr 8.8	16	2102010189
51	Cylinder Head (1st)	2	2601023100
52	Head - Cylinder Gasket (1st)	2	2601026130
53	Cylinder Head (2nd)	1	2601029991
54	Head - Cylinder Gasket (2nd)	1	2601024331
55	Compression Ring (1st)	4	2601026840
56	Oil Control Ring (1st)	4	2601026860
57	Piston Pin Snap Ring (1st)	6	2601026880
58	Piston Pin (1st)	2	2601026990
59	Piston (1st)	2	2601026820
60	Cylinder (1st)	2	2601026261
61	Cylinder Nut (1st); M10	12	2102030065
62	Cylinder Bolt Copper Washer (1st); M10	12	2102040140
63	Cylinder Bolt (1st); M10 x L40, Gr 8.8	8	2601024620
64	Cylinder - Case Gasket	3	2601026310
65	Compression Ring (2nd)	3	2601024970
66	Oil Control Ring (2nd)	2	2601024990
67	Piston (2nd)	1	2601030090
68	Piston Pin (2nd)	1	2601030120
69	Cylinder (2nd)	1	2601030021
70	Cylinder Bolt (1st); M10 x L43, Gr 8.8	4	2601030010
71	Connecting Rod Assembly (1st)	2	2601027000
72	Connecting Rod - Piston Pin Bushing (1st)	2	2501020130
73	Connecting Rod Crank Pin Metal (1st)	6	2601026900
74	Oil Splash Dipper	2	2601030280
75	Oil Splash Dipper Bolt Spring Washer; M5	3	2102040132
76	Oil Splash Dipper Bolts; M5 x L16, Gr 8.8	3	2102011566
77	Connecting Rod Assembly (2nd)	1	2601030131
78	Connecting Rod - Piston Pin Needle Bearing (2nd)	1	2110090026
79	Oil Splash Dipper	1	2601030290

ITEM	DESCRIPTION	QTY	PART NUMBER
CRANKCASE & CRANKSHAFT			
80	Breather Assembly (Rubber)	1	CCC1258
81	Rear Bearing Cover Bolt; M10 x L25, Gr 8.8	10	2102010276
82	Rear Bearing Cover Bolt Copper Washer; M10	10	2102040074
83	Rear Bearing Cover	1	2601029750
84	Rear Bearing Cover Gasket	1	2601029810
85	Oil Baffle	1	2601029870
86	Front & Rear Bearing	2	2110060021
87	Crankshaft Counterweight Bolt; M12 x L72, Gr 8.8	2	2601026430
88	Crankshaft Counterweight Lockwasher	2	2601026440
89	Crankshaft Counterweight	1	2601029620
90	Crankshaft	1	2601030040
91	V-Pulley Pin	1	2601029650
92	Oil Level Glass Bolt; M5 x L20, Gr 8.8	4	VH1470
93	Oil Level Glass Push Cover	1	2601026780
94	Oil Level Glass Assembly	1	2601026740
95	Oil Level Glass Gasket	1	2601026770
96	Crankcase Oil Plug (1/2" PT)	1	2102020061
97	Crankcase	1	2601029690
98	Oil Fill Cap	1	CCC1257
99	O-ring (Oil Fill Cap)	1	CALL FACTORY
100	Front Bearing Cover Gasket	1	2601026520
101	Front Bearing Cover	1	2601029711
102	Front Oil Seal	1	2601029860
103	Compressor Pulley	1	2601234581
104	Compressor Fan	1	2601232610
105	Compressor Fan Spring Washer, M8	6	2102010437
106	Compressor Fan Bolt; M8 x L30, Gr 8.8	6	2102010195
107	Compressor Pulley Thrust Washer	1	2601232980
108	Compressor Pulley Spring washer; M12	1	2102040143
109	Compressor Pulley Bolt; M12 x L40, Gr 8.8	1	2102010405
DISCHARGE PIPING			
110	Outlet Piping Joint	3	2601490971
111	Discharge Piping Assembly - Short	1	2601491971
112	Outlet Piping Joint	1	2601492011
113	Discharge Piping Assembly - Long	1	2601492030
UNLOADER PIPING			
114	Unloader Elbow	1	2101080140
115	Unloader Tube Assembly	2	2601410140
116	Unloader Copper Tee	2	2101090006
117	Unloader Connection Ferrule	1	2101100001
118	Unloader Tube Nut	1	2101110001

NOTES



CA SERIES

E23B COMPRESSOR PUMP PARTS LIST

LOT NUMBER:

RECORD MODEL & SERIAL NUMBER BELOW:

MODEL: _____

SERIAL: _____

Curtis Toledo Inc
1905 Kienlen Avenue, St Louis, Missouri 63133
Tel: (314) 383-1300 Fax: (314) 381-1439
www.fscurtis.com

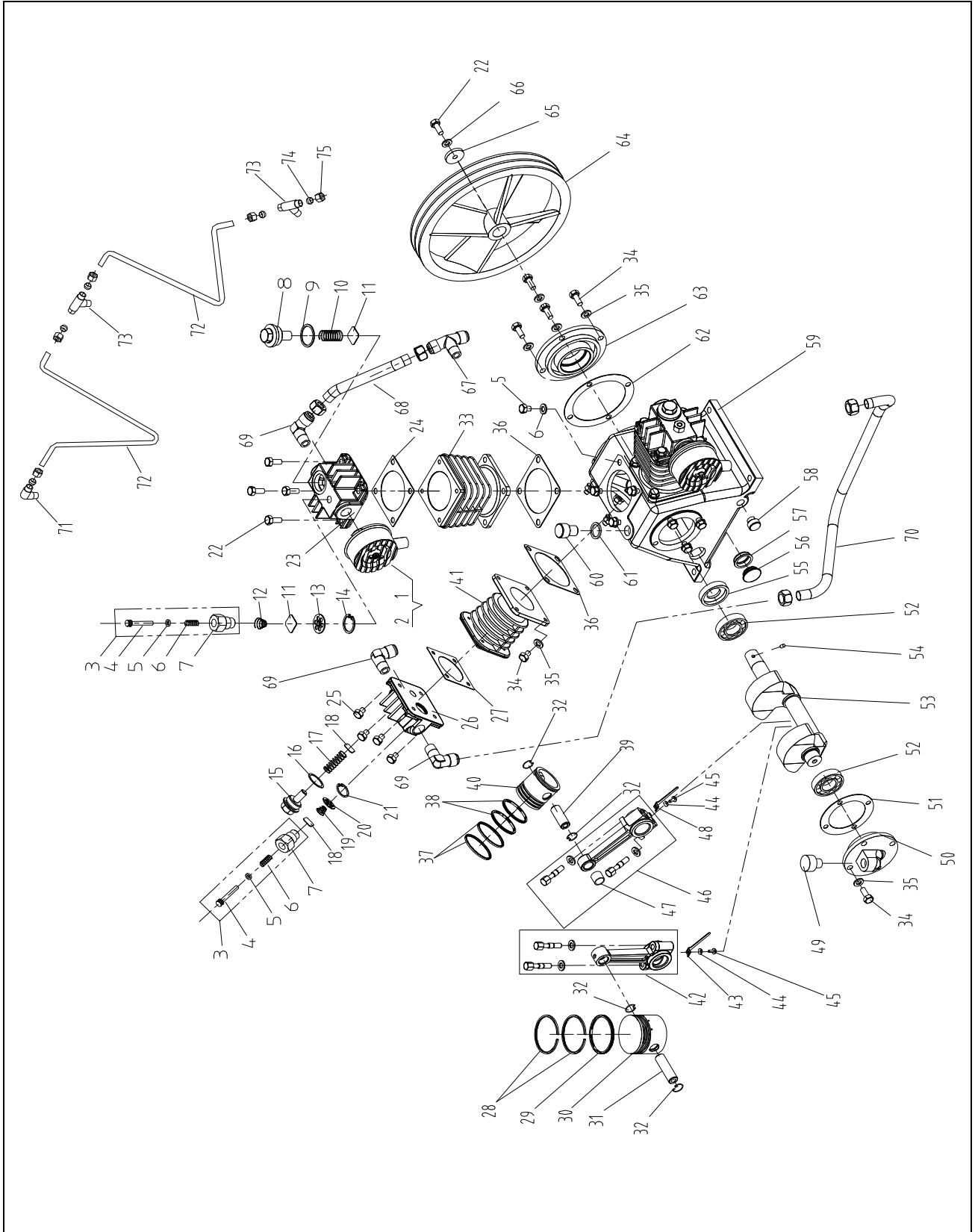

ITEM	DESCRIPTION	QTY	PART NUMBER
AIR STRAINER			
1	Air Strainer Assembly	2	2601540010
2	Air Strainer Element (Not Shown)	2	2601540050
VALVE & UNLOADERS			
3	Unloader Assembly	3	2601021441
4	Unloader Piston	3	2601021471
5	O-Ring (Unloader)	3	2111010004
6	Unloader Spring	3	2601021490
7	Unloader Cylinder	3	2601021450
8	Outlet Valve Push Cover (1st)	2	2601021510
9	Outlet Valve Push Cover Gasket (1st)	2	2601021531
10	Outlet Valve Spring (1st)	2	2601320030
11	Inlet & Outlet Valve Plate (1st)	4	2501310020
12	Inlet Valve Spring (1st)	2	2601310190
13	Inlet Valve Receiver (1st)	2	2601310170
14	Inlet Valve Snap Ring (1st)	2	2111030029
15	Outlet Valve Push Cover (2nd)	1	2601020280
16	Outlet Valve Push Cover Gasket (2nd)	1	2601020300
17	Outlet Valve Spring (2nd)	1	2601320390
18	Inlet & Outlet Valve Plate (2nd)	2	2501310010
19	Inlet Valve Spring (2nd)	2	2601311470
20	Inlet Valve Receiver (2nd)	1	2601310010
21	Inlet Valve Snap Ring (2nd)	1	2111030027
CYLINDERS HEAD			
22	Cylinder Head Bolt (1st); M8 x L25, Gr 8.8	9	2111030027
23	Cylinder Head (1st)	2	2601021340
24	Head - Cylinder Gasket (1st)	2	2601021380
25	Cylinder Head Bolt (2nd); M6 x L25, Gr 8.8	4	2102010136
26	Cylinder Head (2nd)	1	2601029360
27	Cylinder & Head Gasket (2nd)	1	2601020130
CYLINDER, PISTON & RING			
28	Compression Ring (1st)	4	2601021890
29	Oil Control Ring (1st)	2	2601035680
30	Piston (1st)	2	2601035670
31	Piston Pin (1st)	2	2601021940
32	Piston Pin Snap Ring (1st)	6	2601021930
33	Cylinder (1st)	2	2601021570
34	Cylinder Bolt (1st); M8 x L20, Gr 8.8	20	2102010180
35	Cylinder Bolt Copper Washer (1st); M8	20	2102040082
36	Cylinder - Case Gasket	3	2601021620
37	Compression Ring (2nd)	2	2601020810

ITEM	DESCRIPTION	QTY	PART NUMBER
CYLINDER, PISTON & RING, cont.			
38	Oil Control Ring (2nd)	2	2601020840
39	Piston Pin (2nd)	1	2601029480
40	Piston (2nd)	1	2601029450
41	Cylinder (2nd)	1	2601029400
CONNECTING ROD & OIL SPLASH DIPPER			
42	Connecting Rod Assembly (1st)	2	2601021950
43	Oil Splash Dipper	2	2601025702
44	Oil Splash Dipper Bolt Spring Washer; M4	2	2102040129
45	Oil Splash Dipper Bolts; M4 x L10, Gr 8.8	3	2102011517
46	Connecting Rod Assembly (2nd)	1	2601035820
47	Connecting Rod - Piston Pin Bushing	1	2601035810
48	Oil Splash Dipper	1	2601029280
CRANKCASE & CRANKSHAFT			
49	Breather Assembly (Rubber)	1	2601020730
50	Rear Bearing Cover	1	2601025620
51	Rear Bearing Cover Gasket	1	2601025650
52	Front & Rear Bearing	2	2110020084
53	Crankshaft	1	2601035560
54	V-Pulley Pin	1	2601021680
55	Front Oil Seal	1	2601025680
56	Screw-in Oil Level Glass	1	2601037952
57	O-ring (Oil Level Glass)	1	2111010210
58	Crankcase Oil Plug (1/4" PT)	1	2102020029
59	Crankcase	1	2601029430
60	Oil Fill Cap	1	2601020600
61	O-ring (Oil Fill Cap)	1	2111010012
62	Front Bearing Cover Gasket	1	2601025590
63	Front Bearing Cover	1	2601025560
64	Compressor Pulley	1	2601234241
65	Compressor Pulley Thrust Washer	1	2601230800
66	Compressor Pulley Spring washer; M8	1	2102040137
DISCHARGE PIPING			
67	Outlet Piping Joint	1	2601491741
68	Discharge Piping Assembly	1	2601491770
69	Outlet Piping Joint	3	2601490751
70	Discharge Piping Assembly	1	2601491800
UNLOADER PIPING			
71	Unloader Elbow	1	2101080140
72	Unloader Tube Assembly	2	2601410270
73	Unloader Copper Tee	2	2101090006
74	Unloader Connection Ferrule	1	2101100001
75	Unloader Tube Nut	1	2101100001



CA SERIES

E50B COMPRESSOR PUMP PARTS LIST

LOT NUMBER:

RECORD MODEL & SERIAL NUMBER BELOW:

MODEL: _____

SERIAL: _____

Curtis Toledo Inc
1905 Kienlen Avenue, St Louis, Missouri 63133
Tel: (314) 383-1300 Fax: (314) 381-1439
www.fscurtis.com

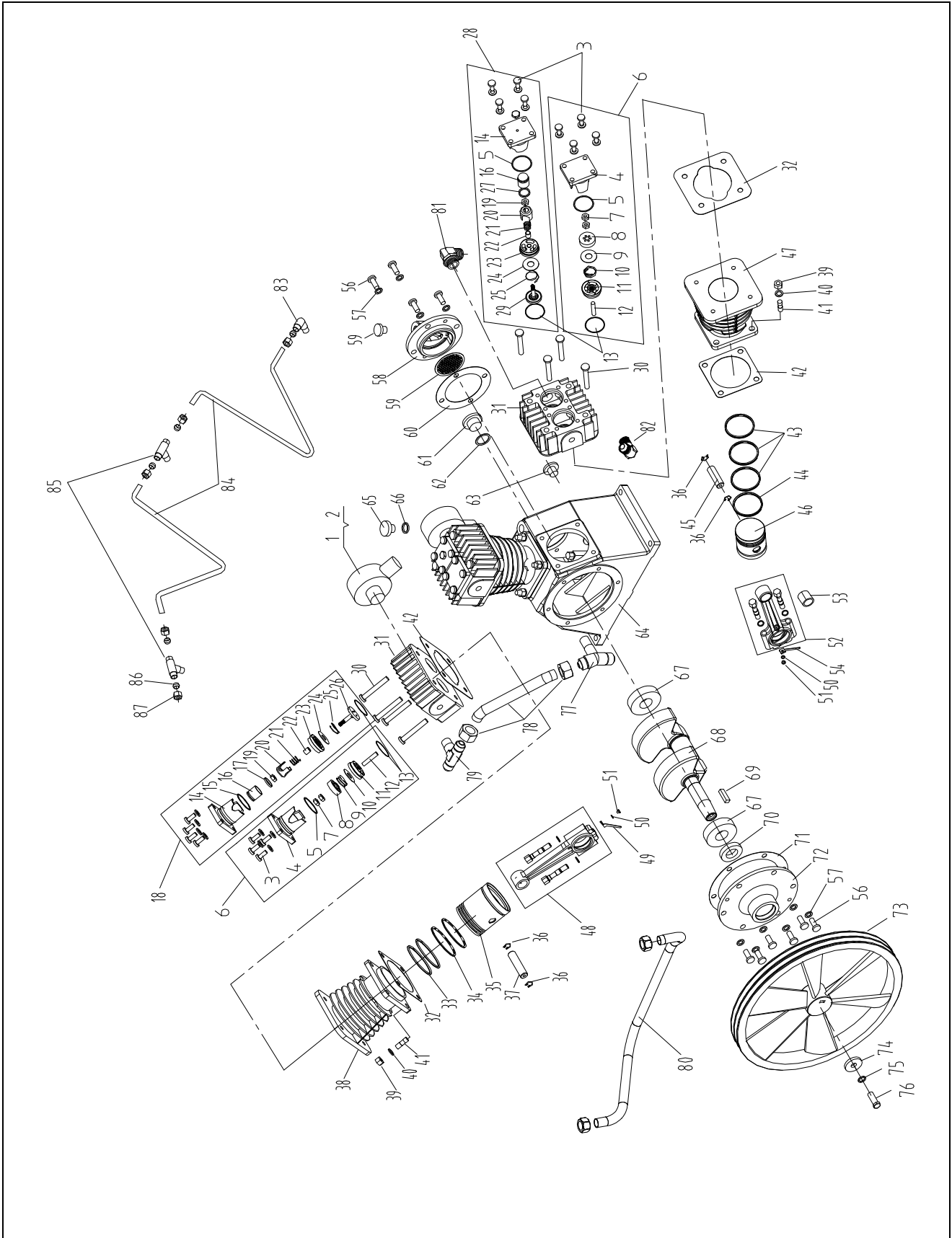

ITEM	DESCRIPTION	QTY	PART NUMBER
AIR STRAINER			
1	Air Strainer Assembly	2	2601540560
2	Air Strainer Element (Not Shown)	2	2601540410
VALVE & UNLOADERS			
3	Outlet Valve Push Cover Bolt; M8 x L20, Gr 8.8	24	2102010180
4	Outlet Valve Push Cover (1st/2nd)	3	2601024510
5	Viton O-ring G 40 (Outlet Valve-1st/2nd)	4	2111010263
6	Outlet Valve Assembly (1st/2nd)	3	2601320070
7	Nut; M8 (Outlet Valve-1st/2nd)	3	2102030118
8	Outlet Valve Receiver (1st/2nd)	3	2601320090
9	Outlet Valve Spring (1st/2nd)	3	2601320110
10	Outlet Valve Plate (1st/2nd)	3	2601310680
11	Outlet Valve Seat (1st/2nd)	3	2601320081
12	Outlet Valve Bolt (1st/2nd)	3	2601320120
13	Inlet & Outlet Valve Gasket (1st/2nd)	6	2601024400
14	Inlet Valve Push Cover (1st/2nd)	3	2601024420
15	O-ring G 40 (Inlet Valve-1st)	2	2111010221
16	Unloader Piston (1st/2nd)	3	2601024450
17	O-ring P 20 (Unloader-1st)	2	2111010014
18	Inlet Valve Assembly-1st	2	2601310630
19	Locknut; M8 (Inlet Valve-1st/2nd)	3	2102030246
20	Inlet Valve Unloader Fork (1st/2nd)	3	2601310700
21	Unloader Spring (1st/2nd)	3	2601024470
22	Inlet Valve Unloader Fork Guide (1st/2nd)	3	2601310710
23	Inlet Valve Seat (1st/2nd)	3	2601310650
24	Inlet Valve Plate (1st/2nd)	3	2501310050
25	Inlet Valve Spring (1st/2nd)	3	2601310690
26	Inlet Valve Receiver (1st)	2	2601310660
27	Viton O-ring P 20 (Unloader-2nd)	1	2111010104
28	Inlet Valve Assembly (2nd)	1	2601311230
29	Inlet Valve Receiver (2nd)	1	2601311250
CYLINDERS HEAD			
30	Cylinder Head Bolt (1st/2nd); M10 x L70, Gr 8.8	12	2102010320
31	Cylinder Head (1st/2nd)	3	2601024290
32	Head - Cylinder Gasket (1st/2nd)	3	2601024331
CYLINDER, PISTON & RING			
33	Compression Ring (1st)	4	2601024970
34	Oil Control Ring (1st)	4	2601024990
35	Piston (1st)	2	2601024961
36	Piston Pin Snap Ring (1st)	6	2601025010
37	Piston Pin (1st)	2	2601025140
38	Cylinder (1st)	2	2601024531

ITEM	DESCRIPTION	QTY	PART NUMBER
39	Cylinder Nut (1st); M10	12	2102030065
40	Cylinder Bolt Copper Washer (1st); M10	12	2102040140
41	Cylinder Bolt (1st); M10 x L40, Gr 8.8	12	2601024620
42	Cylinder - Case Gasket	2	2601024570
43	Compression Ring (2nd)	3	2601021890
44	Oil Control Ring (2nd)	1	2601021910
45	Piston Pin (2nd)	1	2601028650
46	Piston (2nd)	1	2601028610
47	Cylinder (2nd)	1	2601028560
CONNECTING ROD & OIL SPLASH DIPPER			
48	Connecting Rod Assembly (1st)	2	2601025151
49	Oil Splash Dipper	2	2601025702
50	Oil Splash Dipper Bolt Spring Washer; M4	3	2102040129
51	Oil Splash Dipper Bolts; M4 x L12, Gr 8.8	3	2102011524
52	Connecting Rod Assembly (2nd)	1	2601028661
53	Connecting Rod - Piston Pin Needle Bearing (2nd)	1	2110090036
54	Oil Splash Dipper	1	2601029280
CRANKCASE & CRANKSHAFT			
55	Breather Assembly (Rubber)	1	2601020730
56	Rear Bearing Cover Bolt; M10 x L20, Gr 8.8	10	2102010256
57	Rear Bearing Cover Bolt Copper Washer; M10	10	2102040074
58	Rear Bearing Cover	1	2601028380
59	Oil Baffle	1	2601028460
60	Rear Bearing Cover Gasket	1	2601028420
61	Screw-in Oil Level Glass	1	2601037952
62	O-ring (Oil Level Glass)	1	2111010210
63	Crankcase Oil Plug (1/2" PT)	1	2102020061
64	Crankcase	1	2601028590
65	Oil Fill Cap	1	2601024910
66	O-ring (Oil Fill Cap)	1	2111010013
67	Front & Rear Bearing	2	2110020109
68	Crankshaft	1	2601028281
69	V-Pulley Pin	1	2601024660
70	Front Oil Seal	1	2601024870
71	Front Bearing Cover Gasket	1	2601024750
72	Front Bearing Cover	1	2601028350
73	Compressor Pulley	1	2601233640
74	Compressor Pulley Thrust Washer	1	2601231780
75	Compressor Pulley Spring Washer; M12	1	2102040143
76	Compressor Pulley Bolt; M12 x L30, Gr 8.8	1	2102010387

ITEM	DESCRIPTION	QTY	PART NUMBER
DISCHARGE PIPING			
77	Outlet Piping Joint	1	2601490581
78	Discharge Piping Assembly - Short	1	2601491510
79	Outlet Piping Joint	1	2601491491
80	Discharge Piping Assembly - Long	1	2601491580
81	Outlet Piping Joint	1	2601491542
82	Outlet Piping Joint	1	2601491570
UNLOADER PIPING			
83	Unloader Elbow	1	2101080140
84	Unloader Tube Assembly	2	2601410140
85	Unloader Copper Tee	2	2101090006
86	Unloader Connection Ferrule	1	2101100001
87	Unloader Tube Nut	1	2101110001

NOTES



CA SERIES

E15 COMPRESSOR PUMP PARTS LIST

LOT NUMBER:

RECORD MODEL & SERIAL NUMBER BELOW:

MODEL: _____

SERIAL: _____

Curtis Toledo Inc
1905 Kienlen Avenue, St Louis, Missouri 63133
Tel: (314) 383-1300 Fax: (314) 381-1439
www.fscurtis.com

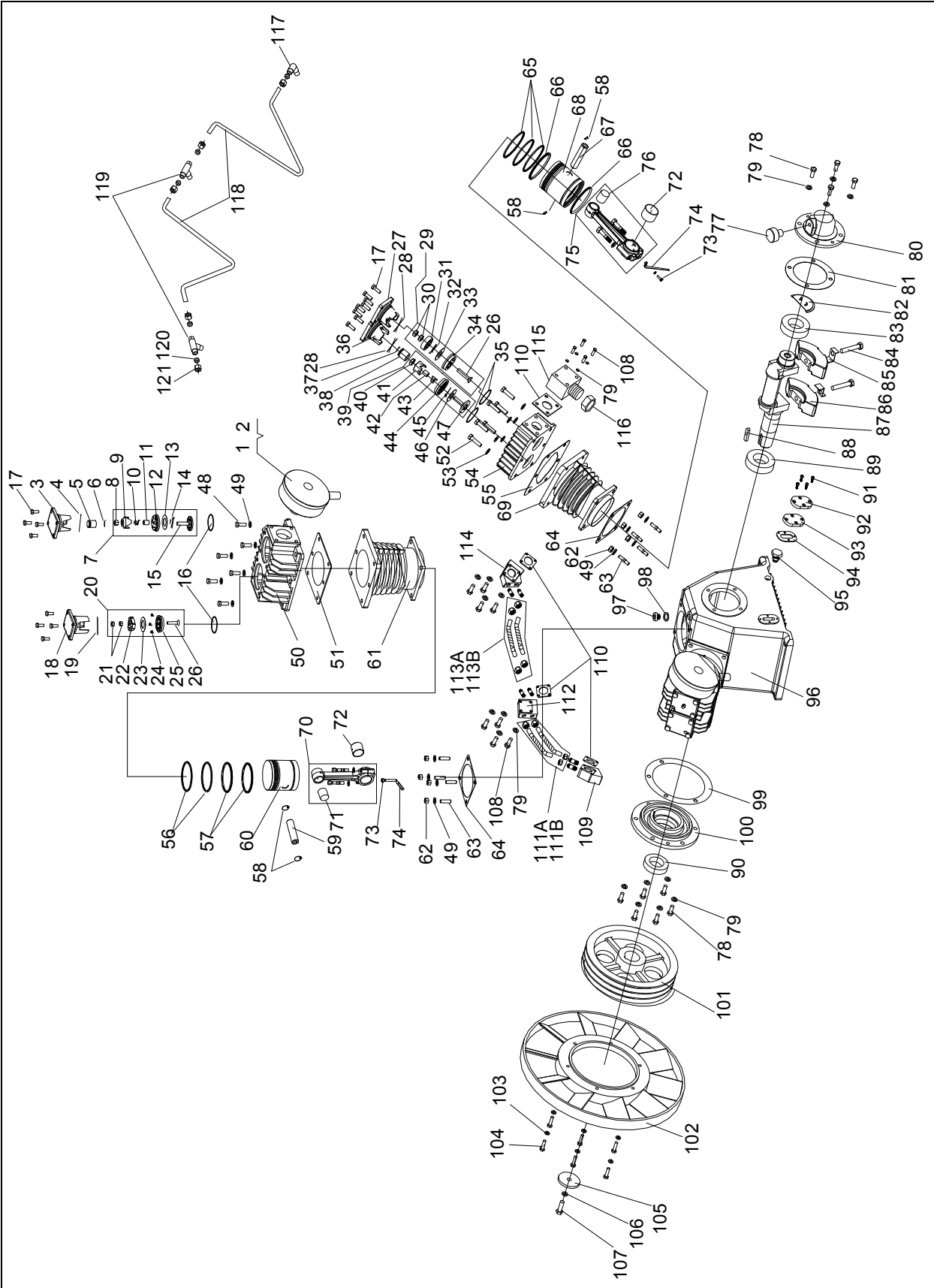

ITEM	DESCRIPTION	QTY	PART NUMBER
AIR STRAINER			
1	Air Strainer Assembly	2	2601540560
2	Air Strainer Element (Not Shown)	2	2601540410
VALVE & UNLOADERS			
3	Inlet Valve Push Cover (1st)	2	2601027641
4	O-ring G 65 (Inlet Valve-1st)	2	2111010270
5	Unloader Piston (1st)	2	2601027660
6	Viton O-ring P 22A (Unloader-1st)	2	2111010108
7	Inlet Valve Assembly-1st	2	2601311120
8	Locknut; M12 (Inlet Valve-1st)	2	2102030206
9	Inlet Valve Unloader Fork (1st)	2	2601311190
10	Inlet Valve Unloader Fork Guide (1st)	2	2601311200
11	Unloader Spring (1st)	2	2601027680
12	Inlet Valve Seat (1st)	2	2601311141
13	Inlet Valve Plate (1st)	2	2501310130
14	Inlet Valve Spring (1st)	2	2601311180
15	Inlet Valve Receiver (1st)	2	2601311153
16	Inlet & Outlet Valve Gasket (1st)	4	2601027620
17	Outlet Valve Push Cover Bolt; M10 x L25, Gr 8.8	24	2102010265
18	Outlet Valve Push Cover (1st)	2	2601027691
19	Viton O-ring G 65 (Outlet Valve-1st)	2	2111010270
20	Outlet Valve Assembly (1st)	2	2601320311
21	Nut; M10 (Outlet Valve-1st)	4	2102030064
22	Outlet Valve Receiver (1st)	2	2601320345
23	Outlet Valve Plate (1st)	2	2501320081
24	Outlet Valve Spring (1st)	6	2601320376
25	Outlet Valve Seat (1st)	2	2601320333
26	Outlet Valve Bolt; M10 x L50, Gr 8.8 (1st)	3	2102011755
27	Outlet Valve Push Cover (2nd)	1	2601031350
28	Viton O-ring G 55 (Outlet Valve-2nd)	2	2111010267
29	Outlet Valve Assembly (2nd)	1	2601320460
30	Nut; M8 (Outlet Valve-2nd)	1	2102030064
31	Outlet Valve Receiver (2nd)	1	2601320470
32	Outlet Valve Spring (2nd)	1	2601320220
33	Outlet Valve Plate (2nd)	1	2501320120
34	Outlet Valve Seat (2nd)	1	2601320202
35	Inlet & Outlet Valve Gasket (2nd)	2	2601026190
36	Inlet Valve Push Cover (2nd)	1	2601031330
37	Viton O-ring P 21 (Unloader-2nd)	1	2111010105
38	Unloader Piston (2nd)	1	2601026230
39	Inlet Valve Assembly (2nd)	1	2601311650
40	Locknut; M10 (Inlet Valve-2nd)	3	2102030248

ITEM	DESCRIPTION	QTY	PART NUMBER
VALVES & UNLOADERS, cont.			
41	Inlet Valve Unloader Fork (2nd)	1	2601310950
42	Unloader Spring (2nd)	1	2601026240
43	Inlet Valve Unloader Fork Guide (2nd)	1	2601310960
44	Inlet Valve Seat (2nd)	1	2601310901
45	Inlet Valve Plate (2nd)	1	2501310100
46	Inlet Valve Spring (2nd)	1	2601310940
47	Inlet Valve Receiver (2nd)	1	2601311670
CYLINDERS HEAD			
48	Cylinder Head Bolt (1st); M12 x L35, Gr 8.8	12	2102010396
49	Cylinder Head Bolt Spring Washer; M12	12	2102040143
50	Cylinder Head (1st)	2	2601030500
51	Head - Cylinder Gasket (1st)	2	2601030530
52	Cylinder Head Bolt (2nd); M10 x L100, Gr 8.8	6	2102010349
53	Cylinder Head Bolt Spring Washer; M10	6	2102040140
54	Cylinder Head (2nd)	1	2601031300
55	Head - Cylinder Gasket (2nd)	1	2601026130
CYLINDER, PISTON & RING			
56	Compression Ring (1st)	4	2601027730
57	Oil Control Ring (1st)	4	2601027740
58	Piston Pin Snap Ring (1st)	6	2601027750
59	Piston Pin (1st)	2	2601027850
60	Piston (1st)	2	2601027850
61	Cylinder (1st)	2	2601030591
62	Cylinder Nut; M12	12	2102030073
63	Cylinder Bolt; M12 x L46, Gr 8.8	12	2601030680
64	Cylinder - Case Gasket	3	2601030630
65	Compression Ring (2nd)	3	2601026840
66	Oil Control Ring (2nd)	2	2601026860
67	Piston Pin (2nd)	1	2601031481
68	Piston (2nd)	1	2601031441
69	Cylinder (2nd)	1	2601031360
CONNECTING ROD & OIL SPLASH DIPPER			
70	Connecting Rod Assembly (1st)	2	2601027860
71	Connecting Rod - Piston Pin Bushing (1st)	2	2501020290
72	Connecting Rod Crank Pin Metal (1st)	6	2601027780
73	Oil Splash Dipper	3	2601031021
74	Oil Splash Dipper Nut; M8	3	2102030060
75	Connecting Rod Assembly (2nd)	1	2601031491
76	Connecting Rod - Piston Pin Needle Bearing (2nd)	1	2110090016

ITEM	DESCRIPTION	QTY	PART NUMBER
CRANKCASE & CRANKSHAFT			
77	Breather Assembly (Rubber)	1	2601026671
78	Rear Bearing Cover Bolt; M10 x L25, Gr 8.8	10	2102010265
79	Rear Bearing Cover Bolt Copper Washer; M10	26	2102040074
80	Rear Bearing Cover	1	2601029750
81	Rear Bearing Cover Gasket	1	2601029810
82	Oil Baffle	1	2601029870
83	Rear Bearing	1	2110060021
84	Crankshaft Counterweight Bolt; M12 x L72, Gr 8.8	2	2601030741
85	Crankshaft Counterweight Lockwasher	2	2601030750
86	Crankshaft Counterweight	2	2601030722
87	Crankshaft	1	2601031380
88	V-Pulley Pin	1	2601029650
89	Front Bearing	1	2110060070
90	Front Oil Seal	1	2601029860
91	Oil Level Glass Bolt; M5 x L20, Gr 8.8	4	2102011571
92	Oil Level Glass Push Cover	1	2601026780
93	Oil Level Glass Assembly	1	2601026740
94	Oil Level Glass Gasket	1	2601026770
95	Crankcase Oil Plug (1/2" PT)	1	2102020061
96	Crankcase	1	2601031410
97	Oil Fill Cap	1	2601024881
98	O-ring (Oil Fill Cap)	1	2111010013
99	Front Bearing Cover Gasket	1	2601030820
100	Front Bearing Cover	1	2601030790
101	Compressor Pulley	1	2601235151
102	Compressor Fan	1	2601234880
103	Compressor Fan Spring Washer, M8	6	2102040137
104	Compressor Fan Bolt; M8 x L30, Gr 8.8	6	2102010195
105	Compressor Pulley Thrust Washer	1	2601232980
106	Compressor Pulley Spring washer; M12	1	2102040143
107	Compressor Pulley Bolt; M12 x L50, Gr 8.8	1	2102010415
DISCHARGE PIPING			
108	Outlet Piping Joint Bolt; M10 x L65, Gr 8.8	16	2102010314
109	Outlet Piping Joint	1	2601492290
110	Gasket Manifold	4	2601491240
111a.	Discharge Piping Assembly (Long), 1st	1	2601492390
111b.	Discharge Piping Assembly (Short), 1st	1	2601492410
112	Outlet Piping Joint	1	2601492510
113a.	Discharge Piping Assembly (Long), 2nd	1	2601492570
113b.	Discharge Piping Assembly (Short), 2nd	1	2601492590
114	Outlet Piping Joint	1	2601492510
115	Outlet Piping Joint	1	2601492540
116	Outlet Piping Joint Nut	1	2601492560

ITEM	DESCRIPTION	QTY	PART NUMBER
UNLOADER PIPING			
117	Unloader Elbow	1	2101080140
118	Unloader Tube Assembly	2	2601410360
119	Unloader Copper Tee	2	2101090006
120	Unloader Connection Ferrule	1	2101100001
121	Unloader Tube Nut	1	2101110001



CA SERIES

E35B COMPRESSOR PUMP PARTS LIST

LOT NUMBER:

RECORD MODEL & SERIAL NUMBER BELOW:

MODEL: _____

SERIAL: _____

Curtis Toledo Inc
1905 Kienlen Avenue, St Louis, Missouri 63133
Tel: (314) 383-1300 Fax: (314) 381-1439
www.fscurtis.com

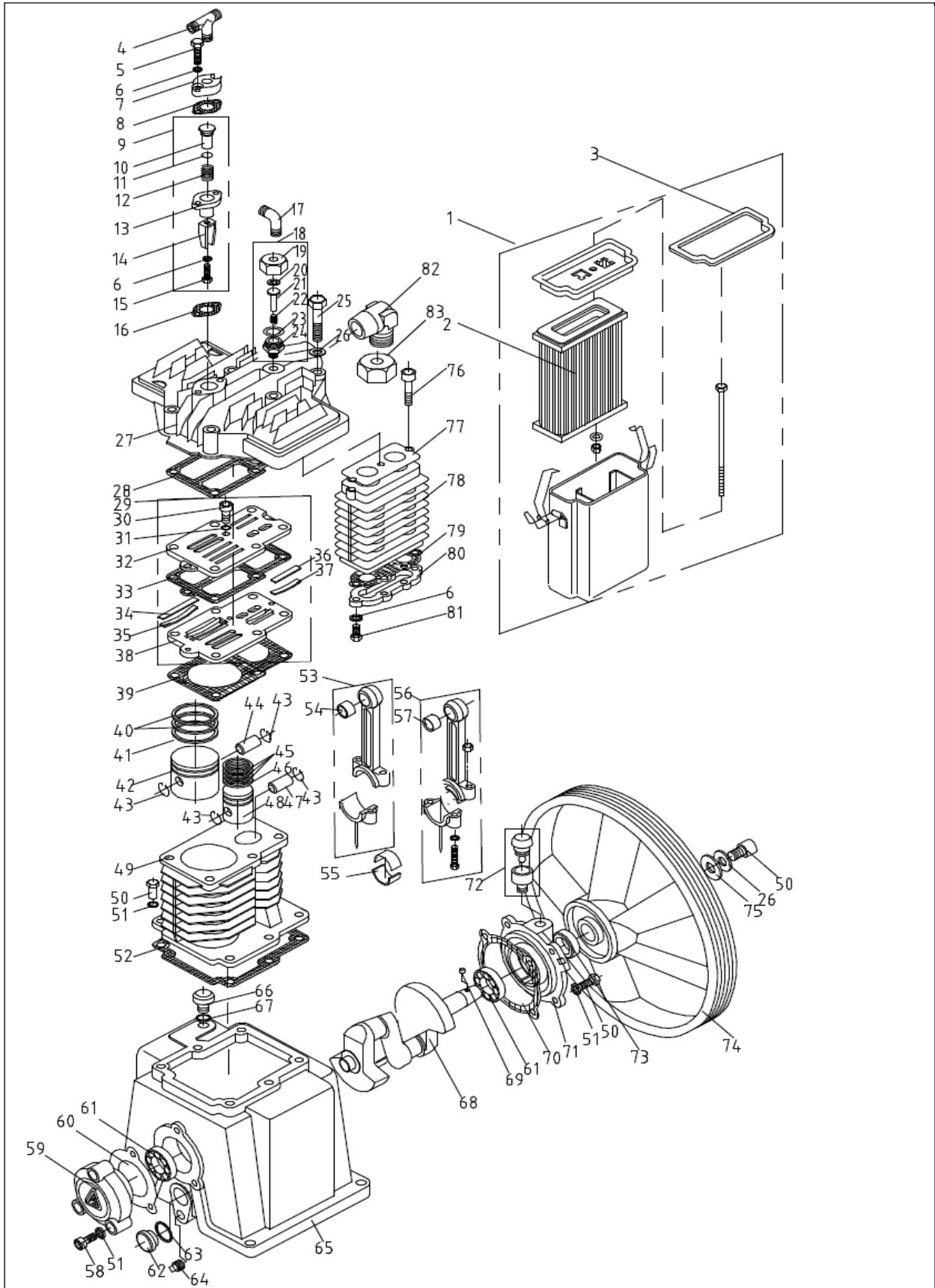

ITEM	DESCRIPTION	QTY	PART NUMBER
AIR STRAINER			
1	Air Strainer Assembly	1	2601540161
2	Air Strainer Element	1	2601540200
3	Air Strainer Cover Gasket	1	2601540220
UNLOADER			
4	Unloader Copper Tee	1	2101090006
5	Unloader Push Cover Bolt; M6 x L25, Gr 8.8 (1st)	2	2102011103
6	Unloader Push Cover Spring Washer; M6 (1st)	7	2102040134
7	Unloader Push Cover (1st)	1	2601022970
8	Unolader Push Cover Gasket (1st)	1	2601023030
9	Unloader Assembly (1st)	1	2601022261
10	Unloader Piston (1st)	1	2601022952
11	Viton O-Ring Unloader (1st)	1	2111010101
12	Unloader Spring (1st)	1	2601022961
13	Unloader Cylinder (1st)	1	2601022941
14	Unloading Fork (1st)	1	2601310290
15	Unloader Bolt; M6 x L16 Gr 8.8 (1st)	1	2102011095
16	Unloader Gasket (1st)	1	2601035400
17	Unloading Elbow	1	2688360780
18	Unloader Assembly (2nd)	1	2601022320
19	Unloader Push Cover (2nd)	1	2601022290
20	Viton O-Ring Unloader (2nd)	1	2111010092
21	Unloader Piston (2nd)	1	2601022331
22	Unloader Spring (2nd)	1	2601022280
23	Unloader Copper Washer (2nd)	1	2601022340
24	Unloader Body (2nd)	1	2601022940
CYLINDER HEAD			
25	Cylinder Head Bolt; M8 x L70, Gr 8.8	6	2102010227
26	Cylinder Head Spring Washer; M8	7	2102040137
27	Cylinder Head	1	2601022200
28	Cylinder Head - Valve Seat Gasket	1	2601022220
VALVE ASSEMBLY			
29	Valve Plate Assembly	1	2601310240
30	Valve Seat Bolt; M5 x L12, Gr 8.8	3	2102011070
31	Valve Seat Bolt Spring Washer; M5	3	2102040132
32	Valve Seat (Upper)	1	2601310250
33	Valve Seat Gasket	1	2601310300
34	Valve Plate (1st)	4	2601310270
35	Valve Plate Spring (1st)	4	2601310281

ITEM	DESCRIPTION	QTY	PART NUMBER
VALVE ASSEMBLY, cont.			
36	Valve Plate (2nd)	2	2601310350
37	Valve Plate Spring (2nd)	2	2601310361
38	Valve Seat (Bottom)	1	2601310260
39	Cylinder-Valve Seat Gasket	1	2601310310
CYLINDER, PISTON & RING			
40	Compression Ring (1st)	2	2601022560
41	Oil Control Ring (1st)	1	2601022570
42	Piston (1st)	1	2601022550
43	Piston Snap Ring	4	2601022580
44	Piston Pin (1st)	1	2601022610
45	Compression Ring (2nd)	3	2601022670
46	Oil Control Ring (2nd)	1	2601022680
47	Piston Pin (2nd)	1	2601022700
48	Piston (2nd)	1	2601022660
49	Cylinder	1	2601022360
50	Cylinder Bolt; M8 x L30, Gr 8.8	11	2102010196
51	Cylinder Copper Washer; M8	7	2102040082
52	Cylinder Crankcase Gasket	1	2601022380
CONNECTING ROD			
53	Connecting Rod Assembly (1st)	1	2601022620
54	Connecting Rod - Piston Pin Bushing (1st)	1	2601022590
55	Connecting Rod Crank Pin Metal (1st)	4	2601022600
56	Connecting Rod Assembly (2nd)	1	2601022710
57	Connecting Rod - Piston Pin Bushing (2nd)	1	2601022690
CRANKCASE & CRANKSHAFT			
58	Rear Bearing Cover Bolt; M8 x L30, Gr 8.8	3	2102011146
59	Rear Bearing Cover	1	2601022480
60	Rear Bearing Cover Gasket	1	2601022520
61	Front & Rear Bearing	2	2110020084
62	Plug-in Oil Level Glass	1	2601020740
63	Oil Level Glass Gasket	1	2601020770
64	Crankcase Oil Plug (Special non-standard)	1	2601023080
65	Crankcase	1	2601022420
66	Oil Fill Cap	1	2601020620
67	O-ring (Oil Fill Cap)	1	2111010012
68	Crankshaft	1	2601022400
69	V-Pulley Pin	1	2601021680
70	Front Bearing Cover Gasket	1	2601022460
71	Front Bearing Cover	1	2601022430
72	Breather Assembly	1	
73	Front Oil Seal	1	2601027590
74	Compressor Pulley	1	2601230840
75	Compressor Pulley Thrust Washer	1	2601230800

ITEM	DESCRIPTION	QTY	PART NUMBER
INTER-COOLER			
76	Inter-Cooler Bolt (Upper)	3	2102011158
77	Inter-Cooler Body Gasket (Upper)	1	2601510070
78	Inter-Cooler Body	1	2601510030
79	Inter-Cooler Body Gasket (Bottom)	1	2601510100
80	Inter-Cooler Cover	1	2601510040
81	Inter-Cooler Bolt (Bottom)	4	2102010130
82	Discharge Elbow	1	2601490450
83	Discharge Elbow Nut	1	2688360270

NOTES



CA SERIES

E11B COMPRESSOR PUMP PARTS LIST

LOT NUMBER:

RECORD MODEL & SERIAL NUMBER BELOW:

MODEL: _____

SERIAL: _____

Curtis Toledo Inc
1905 Kienlen Avenue, St Louis, Missouri 63133
Tel: (314) 383-1300 Fax: (314) 381-1439
www.fscurtis.com

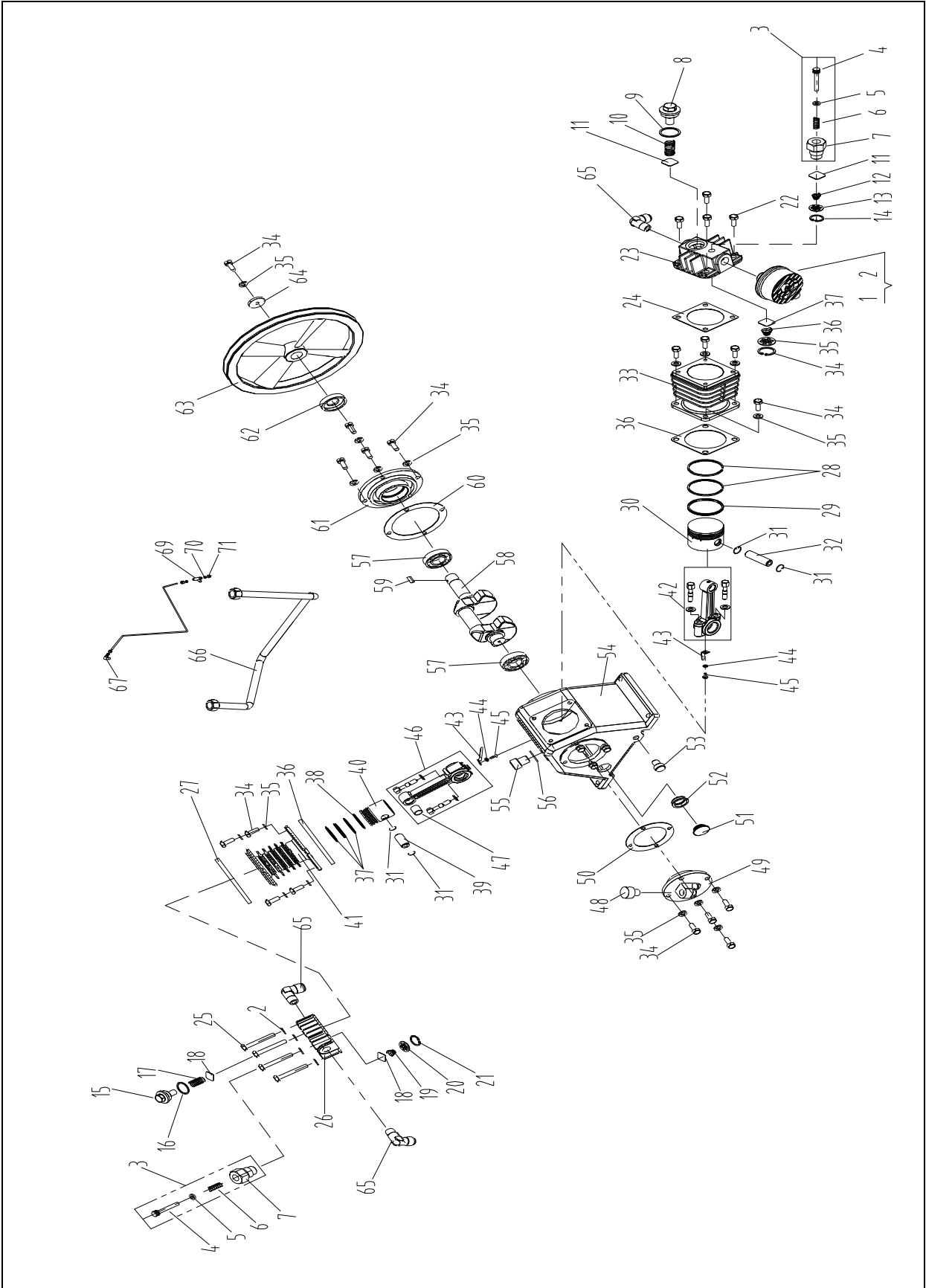

ITEM	DESCRIPTION	QTY	PART NUMBER
AIR STRAINER			
1	Air Strainer Assembly	2	2601540010
2	Air Strainer Element (Not Shown)	2	2601540050
VALVE & UNLOADERS			
3	Unloader Assembly	2	2601021441
4	Unloader Piston	2	2601021471
5	O-ring (Unloader)	2	2111010004
6	Unloader Spring	2	2601021490
7	Unloader Cylinder	2	2601021450
8	Outlet Valve Push Cover (1st)	1	2601021510
9	Outlet Valve Push Cover Gasket (1st)	1	2601021531
10	Outlet Valve Spring (1st)	1	2601320030
11	Inlet & Outlet Valve Plate (1st)	2	2601310180
12	Inlet Valve Spring (1st)	1	2601310190
13	Inlet Valve Receiver (1st)	1	2601310170
14	Inlet Valve Snap Ring (1st)	1	2111030029
15	Outlet Valve Push Cover (2nd)	1	2601025831
16	Outlet Valve Push Cover Gasket (2nd)	1	2601025880
17	Outlet Valve Spring (2nd)	1	2601320180
18	Inlet & Outlet Valve Plate (2nd)	2	2601310860
19	Inlet Valve Spring (2nd)	1	2601310870
20	Inlet Valve Receiver (2nd)	1	2601310850
21	Inlet Valve Snap Ring (2nd)	1	2111030026
CYLINDERS HEAD			
22	Cylinder Head Bolt (1st); M8 x L25, Gr 8.8	4	2102010189
23	Cylinder Head (1st)	1	2601021340
24	Head - Cylinder Gasket (1st)	1	2601021381
25	Cylinder Head Bolt (2nd); M8 x L50, Gr 8.8	4	2102010215
26	Cylinder Head (2nd)	1	2601025790
27	Cylinder & Head Gasket (2nd)	1	2601025810
CYLINDER, PISTON & RING			
28	Compression Ring (1st)	2	2601021890
29	Oil Control Ring (1st)	1	2601035680
30	Piston (1st)	1	2601035670
31	Piston Pin Snap Ring (1st)	4	2601021930
32	Piston Pin (1st)	1	2601021940
33	Cylinder (1st)	1	2601021570
34	Cylinder Bolt (1st); M8 x L20, Gr 8.8	17	2102010180
35	Cylinder Bolt Copper Washer (1st); M8	17	2102040082
36	Cylinder - Case Gasket	2	2601021620
37	Compression Ring (2nd)	3	2601025940
38	Oil Control Ring (2nd)	1	2601025950

ITEM	DESCRIPTION	QTY	PART NUMBER
CYLINDER, PISTON & RING, cont.			
39	Piston Pin (2nd)	1	2601025970
40	Piston (2nd)	1	2601025930
41	Cylinder (2nd)	1	2601025890
CONNECTING ROD & OIL SPLASH DIPPER			
42	Connecting Rod Assembly (1st)	1	2601021950
43	Oil Splash Dipper	2	2601025702
44	Oil Splash Dipper Bolt Spring Washer; M4	2	2102040137
45	Oil Splash Dipper Bolts; M4 x L10, Gr 8.8	2	2102011519
46	Connecting Rod Assembly (2nd)	1	2601026001
47	Connecting Rod - Piston Pin Bushing	1	2601025960
CRANKCASE & CRANKSHAFT			
48	Breather Assembly (Rubber)	1	2601020730
49	Rear Bearing Cover	1	2601025620
50	Rear Bearing Cover Gasket	1	2601025650
51	Screw-in Oil Level Glass	1	2601037952
52	O-ring (Oil Level Glass)	1	2111010210
53	Crankcase Oil Plug (1/4" PT)	1	2102020029
54	Crankcase	1	2601025910
55	Oil Fill Cap	1	2601020600
56	O-ring (Oil Fill Cap)	1	2111010012
57	Front & Rear Bearing	2	2110020084
58	Crankshaft	1	2601025490
59	V-Pulley Pin	1	2601021680
60	Front Bearing Cover Gasket	1	2601025590
61	Front Bearing Cover	1	2601025560
62	Front Oil Seal	1	2601025680
63	Compressor Pulley	1	2601232371
64	Compressor Pulley Thrust Washer	1	2601230800
DISCHARGE PIPING			
65	Outlet Piping Joint	3	2601490751
66	Discharge Piping Assembly	1	2601490840
UNLOADER PIPING			
67	Unloader Elbow	1	2101080140
68	Unloader Tube Assembly	1	2601410140
69	Unloader Copper Tee	1	2101090006
70	Unloader Connection Ferrule	1	2101100001
71	Unloader Tube Nut	1	2101110001

CURTIS – TOLEDO, INC.

1905 KIENLEN AVE., ST. LOUIS, MO 63133
TEL. (314) 383-1300 FAX (314) 381-1439
E-MAIL: info@curtistoledo.com
www.fscurtis.com