

EN - english

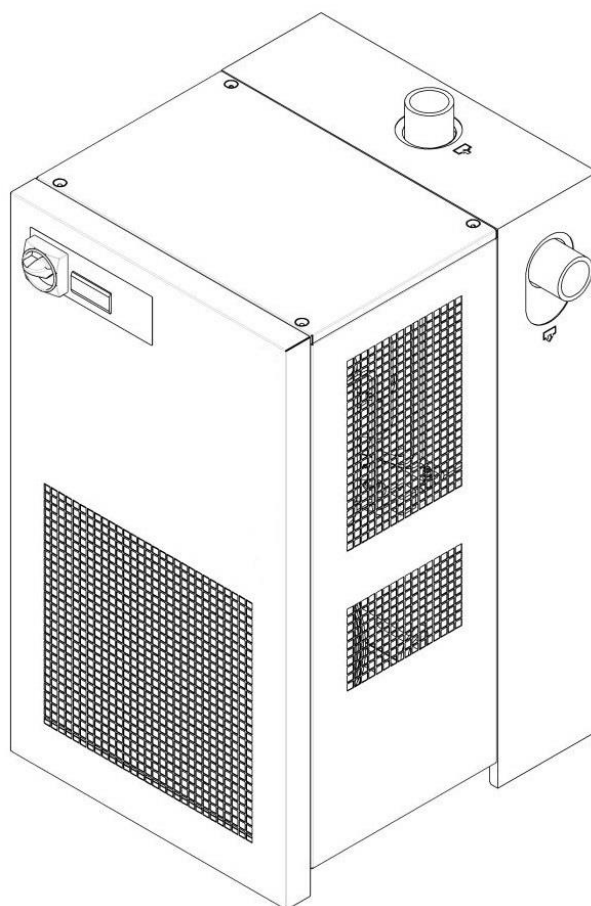

Instructions for installation and operation

Compressed air refrigeration dryer **DRYPOINT® RAC 10-480 NA UL**



Dear customer,

Thank you for deciding in favour of the DRYPOINT® RAC 10-480 NA UL compressed-air refrigeration dryer. Please read these installation and operating instructions carefully before mounting and starting up the DRYPOINT® RAC 10-480 NA UL and follow our directions. Perfect functioning of the DRYPOINT® RAC 10-480 NA UL and thus reliable compressed-air drying can only be guaranteed when the provisions and notes stipulated here are strictly adhered to.

Contents

| | | |
|-----------|---|-----------|
| 1 | Name plate | 5 |
| 2 | Safety instructions | 5 |
| 2.2 | Safety pictograms in accordance with DIN 4844 | 6 |
| 2.3 | Signal words in accordance with ANSI | 7 |
| 2.4 | Overview of the safety instructions | 7 |
| 3 | Proper use | 9 |
| 4 | Exclusion from a field of application | 10 |
| 5 | Instructions for the use of pressure equipment according to PED directive 2014/68/EU | 10 |
| 6 | Transport | 10 |
| 7 | Storage | 11 |
| 8 | Installation | 11 |
| 8.1 | Place of installation | 11 |
| 8.3 | Installation plan | 12 |
| 8.5 | Correction factors | 13 |
| 8.6 | Connection to the compressed-air system | 14 |
| 8.7 | Electrical connections | 14 |
| 8.8 | Condensate drain | 14 |
| 9 | Start-up | 15 |
| 9.1 | Preliminary stages | 15 |
| 9.2 | Initial start-up | 15 |
| 9.3 | Shut down and restart | 16 |
| 10 | Technical data | 17 |
| 10.1 | Technical data DRYPOINT RAC 10-175 NA -P (1/115/60) UL | 17 |
| 10.2 | Technical data DRYPOINT RAC 125-480 NA -E (1/230/60) UL | 18 |
| 11 | Technical description | 19 |
| 11.1 | Control panel | 19 |
| 11.2 | Functional description | 19 |
| 11.3 | Flow chart | 20 |
| 11.4 | Refrigerating compressor | 21 |
| 11.5 | Condenser | 21 |
| 11.6 | Filter dryer | 21 |
| 11.7 | Capillary tube | 21 |
| 11.8 | Aluminium heat exchanger | 21 |
| 11.9 | Hot-gas bypass valve | 21 |
| 11.10 | Refrigerant pressure switches LPS – HPS | 22 |
| 11.11 | Safety temperature switch TS | 22 |
| 11.12 | Electronic instrument DMC35 | 23 |
| 11.12.1 | How to switch on the dryer | 23 |
| 11.12.2 | How to switch off the dryer | 23 |
| 11.12.3 | How a service warning / alarm is displayed | 23 |
| 11.12.4 | How is controlled the condenser fan | 24 |
| 11.12.5 | How is controlled the drain solenoid valve | 24 |
| 11.12.6 | How to display the total hours of operation | 24 |
| 11.12.7 | How to change the operating parameters – SETUP menu | 24 |
| 11.12.8 | Connection to a serial line | 24 |
| 11.13 | Electronically level-controlled BEKOMAT condensate drain | 25 |
| 12 | Maintenance, troubleshooting, spare parts and dismantling | 26 |
| 12.1 | Checks and maintenance | 26 |
| 12.2 | Troubleshooting | 27 |
| 12.3 | Recommended spare-parts | 30 |
| 12.5 | Maintenance works at the refrigeration cycle | 31 |
| 12.6 | Dismantling the dryer | 31 |
| 13 | Appendices | 32 |
| 13.1 | Dryer dimensions | 32 |
| 13.1.1 | Dryer dimensions DRYPOINT RAC 10-15 NA UL | 32 |

Name plate

| | | |
|---------|---|----|
| 13.1.2 | Dryer dimensions DRYPOINT RAC 20-50 NA UL | 33 |
| 13.1.3 | Dryer dimensions DRYPOINT RAC 75 NA UL | 34 |
| 13.1.4 | Dryer dimensions DRYPOINT RAC 100-125 NA UL | 35 |
| 13.1.5 | Dryer dimensions DRYPOINT RAC 150 NA UL | 36 |
| 13.1.6 | Dryer dimensions DRYPOINT RAC 175-220 NA UL | 37 |
| 13.1.7 | Dryer dimensions DRYPOINT RAC 300-375 NA UL | 38 |
| 13.1.8 | Dryer dimensions DRYPOINT RAC 480 NA UL | 39 |
| 13.2 | Exploded diagrams | 40 |
| 13.2.1 | Components of the exploded diagrams | 40 |
| 13.2.2 | Exploded diagram DRYPOINT RAC 10-15 NA UL | 41 |
| 13.2.3 | Exploded diagram DRYPOINT RAC 20-35 NA UL | 42 |
| 13.2.4 | Exploded diagram DRYPOINT RAC 50 NA UL | 43 |
| 13.2.5 | Exploded diagram DRYPOINT RAC 75-100 NA UL | 44 |
| 13.2.6 | Exploded diagram DRYPOINT RAC 125 NA UL | 45 |
| 13.2.7 | Exploded diagram DRYPOINT RAC 150 NA UL | 46 |
| 13.2.8 | Exploded diagram DRYPOINT RAC 175-220 NA UL | 47 |
| 13.2.9 | Exploded diagram DRYPOINT RAC 300-375 NA UL | 48 |
| 13.2.10 | Exploded diagram DRYPOINT RAC 480 NA UL | 49 |
| 13.3 | Electric diagrams | 50 |
| 13.3.1 | Electric diagrams – list of components | 50 |
| 13.3.2 | Electric diagram DRYPOINT RAC 10-100 NA UL | 51 |
| 13.3.3 | Electric diagram DRYPOINT RAC 125-175 NA UL | 52 |
| 13.3.4 | Electric diagram DRYPOINT RAC 220 NA UL | 53 |
| 13.3.5 | Electric diagram DRYPOINT RAC 300 NA UL | 54 |
| 13.3.6 | Electric diagram DRYPOINT RAC 375 NA UL | 55 |
| 13.3.7 | Electric diagram DRYPOINT RAC 480 NA UL | 56 |

1 Name plate

The name plate is on the back of the dryer and comprises all primary data of the device. Always refer to these when contacting the manufacturer or the sales department.

All guarantee claims will expire in the event that the name plate is modified or removed.

2 Safety instructions



Please check whether or not these instructions correspond to the device type.

Please adhere to all advice given in these operating instructions. They include essential information which must be observed during installation, operation and maintenance. Therefore, it must be ensured that these operating instructions are read by the fitter and the responsible operator / certified skilled personnel prior to installation, start-up and maintenance.

The operating instructions must be accessible at all times at the place of application of the DRYPOINT® RAC 10-480 NA UL compressed-air refrigeration dryer.

In addition to these operating instructions, local and national regulations need to be observed, where required.

Ensure that operation of the DRYPOINT® RAC 10-480 NA UL compressed-air refrigeration dryer only takes place within the permissible limit values indicated on the name plate. Any deviation from these limit values involves a risk for persons and for the material, and may result in malfunction or a breakdown.

After installing the device correctly and in accordance with the instructions in this manual, the dryer is ready to operate, further settings are not required. Operation is fully automatic and maintenance is limited to several examinations and cleaning measures which are described in the following chapters.

This manual must be available at all times for future reference and is a constituent part of the dryer.

If you have any queries regarding these installation and operating instructions, please contact BEKO TECHNOLOGIES.

2.2 Safety pictograms in accordance with DIN 4844



Observe operating instructions



General danger symbol



Supply voltage



Danger: component or system under pressure



Hot surfaces



Non-breathable air



Do not use water to extinguish the fire



Do not operate with open cover (housing)



Maintenance works or controlling measures must only be carried out by qualified personnel¹



Do not smoke



Note



Connection point compressed-air inlet



Connection point compressed-air outlet



Connection point condensate drain



Works can be carried out by the operator of the plant, provided that they are skilled accordingly¹.

NOTE: Text that contains important specifications to be considered – does not refer to safety precautions.

¹ Certified skilled personnel are persons who are authorised by the manufacturer, with experience and technical training, who are well-grounded in the respective provisions and laws and capable of carrying out the required works and of identifying and avoiding any risks during the machine transport, installation, operation and maintenance.

Qualified and authorised operators are persons who are instructed by the manufacturer regarding the handling of the refrigeration system, with experience and technical training, and who are well-grounded in the respective provisions and laws.



The device was carefully designed with particular attention paid to environmental protection:

- CFC-free refrigerants
- CFC-free insulation material
- Energy-saving design
- Limited acoustic emissions
- Dryer and packaging comprise reusable materials

This symbol advises the user to observe the environmental aspects and comply with the recommendations connected with this symbol.

2.3 Signal words in accordance with ANSI

| | |
|-------------------|---|
| Danger! | Imminent hazard Consequences of non-observance: serious injury or death |
| Warning! | Potential hazard Consequences of non-observance: possible serious injury or death |
| Caution! | Imminent hazard Consequences of non-observance: possible injury or property damage |
| Notice! | Potential hazard Consequences of non-observance: possible injury or property damage |
| Important! | Additional advice, info, hints Consequences of non-observance: disadvantages during operation and maintenance, no danger |

2.4 Overview of the safety instructions



Certified skilled personnel

Installation works must exclusively be carried out by authorised and qualified skilled personnel. Prior to undertaking any measures on the DRYPOINT® RAC 10-480 NA UL compressed-air refrigeration dryer, the certified skilled personnel shall read up on the device by carefully studying the operating instructions. The operator is responsible for the adherence to these provisions. The respective directives in force apply to the qualification and expertise of the certified skilled personnel.

For safe operation, the device must only be installed and operated in accordance with the indications in the operating instructions. In addition, the national and operational statutory provisions and safety regulations, as well as the accident prevention regulations required for the respective case of application, need to be observed during employment. This applies accordingly when accessories are used.



Danger!

Compressed air!

Risk of serious injury or death through contact with quickly or suddenly escaping compressed air or through bursting and/or unsecured plant components.

Compressed air is a highly dangerous energy source.

Never work on the dryer when the system is under pressure.

Never direct the compressed-air outlet or condensate drain hoses at persons.

The user is responsible for the proper installation of the dryer. Non-observance of the instructions in the "Installation" chapter leads to the expiration of the guarantee. Improper installation may result in dangerous situations for the personnel and/or the device.



Danger!

Supply voltage!

Contact with non-insulated parts carrying supply voltage involves the risk of an electric shock resulting in injuries and death.

Only qualified and skilled personnel are authorised to run electrically-operated devices. Prior to undertaking maintenance measures at the device, the following requirements must be met:

Make sure that the power supply is switched off and that the device is off and marked for maintenance measures. Please also ensure that the power supply cannot be re-established during the works.



Caution!

Refrigerant!

The compressed-air refrigeration dryer uses HFC-containing refrigerants as a coolant.

Please observe the corresponding paragraph entitled "Maintenance works at the refrigeration cycle".



Warning!

Refrigerant leak!

A refrigerant leak involves the danger of serious injury and damage to the environment.



The DRYPOINT® RAC 10-480 NA UL compressed-air refrigeration dryer contains fluorinated greenhouse gas/refrigerant.



Installation, repair and maintenance works at the refrigeration system must only be carried out by certified skilled personnel (specialists). A certification in accordance with EC regulation 303/2008 must be available.



The "hermetically sealed" state is bound to the integrity of the refrigeration circuit. Any tampering or maintenance that compromises the conditions verified during the factory testing phase will invalidate the "hermetically sealed" status.



The requirements of the EC 842/2006 directive must be met under all circumstances.

Please refer to the indications on the name plate as regards the type and amount of refrigerant.

Comply with the following protective measures and rules of conduct:

1. **Storage:** Keep the container tightly closed. Keep it in a cool and dry place. Protect it against heat and direct sunlight. Keep it away from ignition sources.
2. **Handling:** Take measures against electrostatic charging. Ensure good ventilation/suction at the workplace. Check fittings, connections and ducts for tightness. Do not inhale the gas. Avoid contact with the eyes or the skin.
3. Prior to carrying out works on refrigerant-carrying parts, remove the refrigerant to such an extent that safe working is possible.
4. Do not eat, drink or smoke during work. Keep out of the reach of children.
5. **Breathing protection:** ambient-air-independent respirator (at high concentrations).
6. **Eye protection:** sealing goggles.
7. **Hand protection:** protective gloves (e.g. made of leather).
8. **Personal protection:** protective clothing.
9. **Skin protection:** use protective cream.

In addition, the safety data sheet for the refrigerant needs to be observed!



Caution!

Hot surfaces!

During operation, several components can reach surface temperatures of more than 140°F (60°C). There is the risk of burns.

All components concerned are installed inside of the closed housing. The housing must only be opened by certified skilled personnel².

² Certified skilled personnel are persons who are authorised by the manufacturer, with experience and technical training, who are well-grounded in the respective provisions and laws and capable of carrying out the required works and of identifying and avoiding any risks during the machine transport, installation, operation and maintenance.

Qualified and authorised operators are persons who are instructed by the manufacturer regarding the handling of the refrigeration system, with experience and technical training, and who are well-grounded in the respective provisions and laws.



Caution!
Improper use!



The device is intended for the separation of water in compressed air. The dried air cannot be used for breathing-air purposes and is not suitable for the direct contact with food.

This dryer is not suitable for the treatment of contaminated air or of air containing solids.



Note!
Contaminated intake air!

In the event that the intake air is strongly contaminated (ISO 8573.1 class 3.-3 or poorer quality), we recommend the additional installation of a prefilter (e.g. CLEARPOINT F040), to avoid clogging of the heat exchanger.



Caution!
Heating-up through fire!

In the event of a heating-up through fire, the containers and pipes of the refrigerant system can burst.



In this case, please proceed as follows:

Switch off the refrigeration plant.

Switch off the mechanical ventilation of the machinery compartment.

Use ambient-air-independent respirators.

Containers and plants which are filled with refrigerant can burst violently in the event of fire.

The refrigerants themselves are incombustible, but they are degraded to very toxic products at high temperatures.

Remove the container/plant from the fire zone, as there is the risk of bursting!

Cool down containers and bottles via a directed water jet from a safe position.

In the event of fire, please use an approved fire extinguisher. Water is not a suitable agent to extinguish an electrical fire.

This must only be carried out by persons who are trained and informed about the hazards emanating from the product.



Caution!
Unauthorised intervention!

Unauthorised interventions may endanger persons and plants and lead to malfunction.

Unauthorised interventions, modification and abuse of the pressure devices are prohibited.

The removal of sealings and leadings at safety devices is prohibited.

Operators of the devices must observe the local and national pressure equipment regulations in the country of installation.



Note!
Ambient conditions!

In the event that the dryer is not installed under suitable ambient conditions, the ability of the device to condense refrigerant gas is impaired. This can result in a higher load of the refrigerating compressor, and in a loss of efficiency and performance of the dryer.

This in turn leads to overheated condenser fan motors, to malfunction of electric components and to a breakdown of the dryer. Failures of this type will affect warranty considerations.

Do not install the dryer in an environment in which chemicals with a corrosive effect, explosive gases, toxic gases, evaporation heat, high ambient temperatures or extreme dust and dirt can be found.

3 Proper use

This dryer was designed, manufactured and tested to separate the moisture which normally exists in compressed air. Any other use is considered improper.

The manufacturer shall not be liable for problems occurring as a consequence of improper use. The user alone is responsible for any damage resulting from that.

Furthermore, the correct use includes the compliance with the installation instructions, in particular in respect of:

- The voltage and frequency of the main voltage supply.
- The pressure, temperature and flow rate of the inlet air.
- The ambient temperature.

When delivered, the dryer is tested and fully assembled. The customer only needs to connect the device to the system in accordance with the instructions in the following chapters.

4 Exclusion from a field of application



Note!
Improper use!



The device is intended for the separation of water in compressed air. The dried air cannot be used for breathing-air purposes and is not suitable for the direct contact with food.

This dryer is not suitable for the treatment of contaminated air or of air containing solids.

5 Instructions for the use of pressure equipment according to PED directive 2014/68/EU

The DRYPOINT® RAC 10-480 NA UL compressed-air refrigeration dryer contains pressure equipment in the sense of the 2014/68/EC Pressure Equipment Directive. Therefore, the entire plant needs to be registered with the supervisory authority if required in accordance with the local regulations.

For the examination prior to the start-up and for periodic inspections, the national regulations need to be observed, such as the industrial safety regulation in the Federal Republic of Germany. In countries outside the EU, the respective regulations in force there need to be adhered to.

The proper use of pressure devices is the basic requirement for safe operation. As regards pressure devices, the following points need to be observed:

- The DRYPOINT® RAC 10-480 NA UL compressed-air refrigeration dryer must only be employed within the pressure and temperature range limits indicated by the manufacturer on the name plate.
- No welding must be carried out on the pressure parts.
- The DRYPOINT® RAC 10-480 NA UL compressed-air refrigeration dryer must neither be installed in insufficiently ventilated rooms nor near heat sources or inflammable substances.
- To avoid fractures resulting from material fatigue, the refrigeration dryer should not be exposed to vibrations during operation.
- The maximum operating pressure indicated by the manufacturer on the name plate must not be exceeded. It is the installer's responsibility to install the appropriate safety and control devices. Prior to the start-up of the DRYPOINT® RAC 10-480 NA UL compressed-air refrigeration dryer, the connected pressure generator (compressor etc.) must be set to the max. permissible operating pressure. The integrated safeguard needs to be checked by an approved inspection agency.
- The documents related to the DRYPOINT® RAC 10-480 NA UL compressed-air refrigeration dryer (manual, operating instructions, manufacturer's declaration etc.) must be kept safe for future reference.
- No objects whatsoever must be installed at or placed on the DRYPOINT® RAC 10-480 NA UL compressed-air refrigeration dryer and the connecting lines.
- Installation of the plant in frost-free places only.
- Operation of the plant is only permissible with fully closed and intact housing and cover panels. Operation of the plant with damaged housing/cover panels is prohibited.

6 Transport

Check the packaging for visible loss or damage. If no visible damage can be ascertained, place the unit in close proximity to the place of installation and unpack the device.

During this procedure, the dryer must always remain in an upright position. The components may be damaged when the unit is tilted or turned upside down.

Store the device in a dry environment and do not expose it to extreme weather conditions.

Handle with care. Strong shocks can cause irreparable damage.

7 Storage

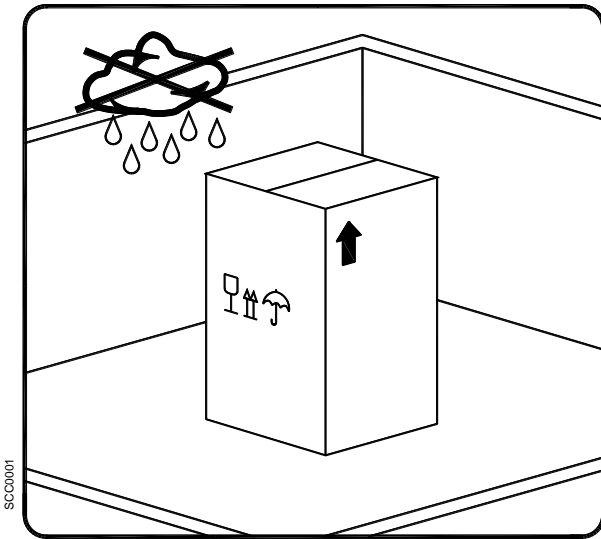

Keep the device away from extreme weather conditions even when packaged.

Keep the dryer in an upright position, also while it is stored. Tilting the device or turning it upside down can cause irreparable damage to some components.

When the dryer is not in use, it can be stored in its packaging in a dust-free and protected place at a temperature of +34°F (+1°C) ... +122°F (+50°C) and at a specific humidity of max. 90%. If the storage period exceeds 12 months, you should contact the manufacturer.



The packaging material is recyclable. Dispose of the material in accordance with the directives and provisions in force in the country of destination

8 Installation

8.1 Place of installation



Note!

Ambient conditions!

In the event that the dryer is not installed under suitable ambient conditions, the ability of the device to condense refrigerant gas is impaired. This can result in a higher load of the refrigerating compressor, and in a loss of efficiency and performance of the dryer.

This in turn leads to overheated condenser fan motors, to malfunction of electric components and to a breakdown of the dryer. Failures of this type will affect warranty considerations.

Do not install the dryer in an environment in which chemicals with a corrosive effect, explosive gases, toxic gases, evaporation heat, high ambient temperatures or extreme dust and dirt can be found.

Minimum installation requirements:

- Choose an area which is clean and dry, free from dust and protected against atmospheric disturbances.
- The load-bearing zone must be even, horizontal and able to bear the weight of the dryer.
- Minimum ambient temperature +34°F (+1°C).
- Maximum ambient temperature +113°F (+45°C).
- Ensure a proper cooling air replacement.
- Allow a sufficient clearance on each side of the dryer for proper ventilation and to facilitate maintenance operations. The dryer does not require attachment to the floor surface.



Do not obstruct the ventilation grille (not even partially).

Prevent any recirculation of the outgoing cooling air.

Protect the dryer against draughts.



Note!

Dryers models DP RAC 10 – 125 can be wall-mounted. See fixing dimensions on dimensional drawings in the appendices section.

The hanging mounting inevitably causes the obstruction of the ventilation grid positioned on the panel facing the wall fixing. This obstruction, in any case, does not prejudice the efficiency of the ventilation inside the dryer which is guaranteed by other grids on the other panels.

8.3 Installation plan

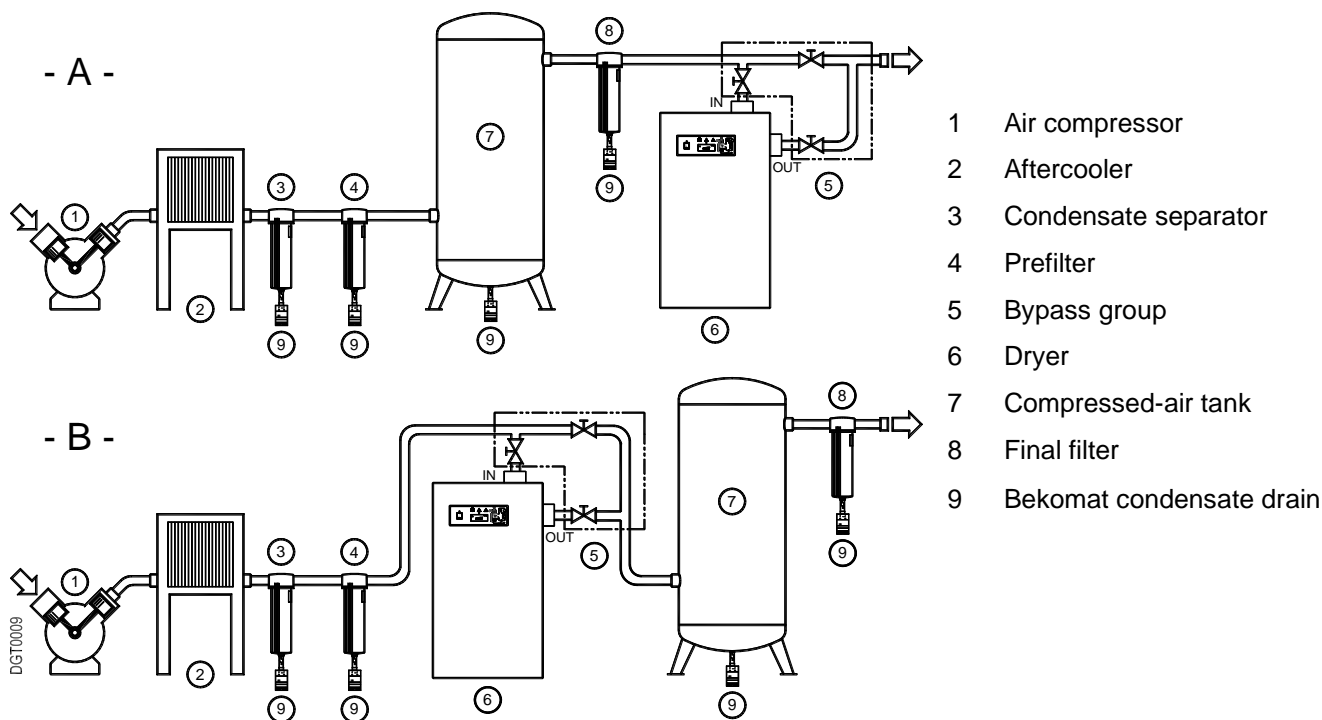

Installation **type A** is recommended when the total consumption corresponds to the throughput rate of the compressor. Installation **type B** is recommended when the air consumption constantly varies, with peak values which considerably exceed the throughput rate of the compressor. The storage capacity of the tank must be dimensioned in such a way that a possible short-term high air demand (peak air consumption) can be compensated.



Do not obstruct the ventilation grille (not even partially).

Prevent any recirculation of the outgoing cooling air.

Protect the dryer against draughts.



Note!

Contaminated intake air!

In the event that the intake air is strongly contaminated (ISO 8573.1 class 3.-3 or poorer quality), we recommend the additional installation of a prefilter (e.g. CLEARPOINT F040), to avoid clogging of the heat exchanger.

8.5 Correction factors

| | | | | | | | | | |
|---|------|------|------|------|------|------|------|------|------|
| Correction factor for operating pressure modifications: | | | | | | | | | |
| Inlet air pressure | psig | 60 | 80 | 100 | 120 | 140 | 160 | 180 | 203 |
| | barg | 4 | 5.5 | 7 | 8 | 10 | 11 | 12 | 14 |
| Factor (F1) | | 0.79 | 0.91 | 1.00 | 1.07 | 1.13 | 1.18 | 1.23 | 1.27 |

| | | | | | | | | |
|--|----|------|------|------|------|------|------|------|
| Correction factor for ambient temperature modifications: | | | | | | | | |
| Ambient temperature | °F | ≤ 80 | 90 | 95 | 100 | 105 | 110 | 115 |
| | °C | ≤ 27 | 32 | 35 | 38 | 40 | 43 | 45 |
| Factor (F2) | | 1.10 | 1.07 | 1.04 | 1.00 | 0.93 | 0.83 | 0.70 |

| | | | | | | |
|--|----|------|------|------|------|------|
| Correction factor for inlet air temperature modifications: | | | | | | |
| Air temperature | °F | ≤ 90 | 100 | 110 | 122 | 130 |
| | °C | ≤ 32 | 38 | 43 | 50 | 55 |
| Factor (F3) | | 1.11 | 1.00 | 0.80 | 0.65 | 0.53 |

| | | | | | |
|---|----|------|------|------|------|
| Correction factor for DewPoint modifications: | | | | | |
| DewPoint | °F | 38 | 41 | 45 | 50 |
| | °C | 3 | 5 | 7 | 10 |
| Factor (F4) | | 0.92 | 1.00 | 1.07 | 1.25 |

Calculation of the actual air throughput:

Actual air throughput = air throughput acc. to planning x factor (F1) x factor (F2) x factor (F3) x factor (F4)

Example:

The **DRYPOINT RAC 75** has a planned nominal capacity of 75 scfm (127 m³/h). The highest achievable air mass under the following operating conditions is:

- Air inlet pressure = 120 psig (8 barg) ⇒ ⇒ Factor (F1) = 1.07
- Ambient temperature = 105°F (40°C) ⇒ ⇒ Factor (F2) = 0.93
- Air inlet temperature = 122°F (50°C) ⇒ ⇒ Factor (F3) = 0.65
- Pressure dew point = 50°F (10°C) ⇒ ⇒ Factor (F4) = 1.25

Every function parameter corresponds to a numerical factor which, multiplied by the planned nominal capacity, determines the following:

Actual air throughput = 75 x 1.07 x 0.93 x 0.65 x 1.25 = 61 scfm (104 m³/h)

61 scfm (104 m³/h) is the maximum flow rate of the dryer under the aforementioned operating conditions.

Selection of the best suitable model in accordance with the operating conditions:

Air throughput acc. to planning = $\frac{\text{Requ. air throughput}}{\text{Factor (F1) x Factor (F2) x Factor (F3) x Factor (F4)}}$

Example:

The following operating parameters are known:

- Required air mass = 100 scfm (170 m³/h) ⇒ ⇒ Factor (F1) = 1.07
- Air inlet pressure = 120 psig (8 barg) ⇒ ⇒ Factor (F2) = 0.93
- Ambient temperature = 105°F (40°C) ⇒ ⇒ Factor (F3) = 0.65
- Air inlet temperature = 122°F (50°C) ⇒ ⇒ Factor (F4) = 1.25
- Pressure dew point = 50°F (10°C)

To find out the correct dryer version, the required air mass must be divided by the correction factors of the parameters indicated above:

Air throughput acc. to planning = $\frac{100}{1.07 \times 0.93 \times 0.65 \times 1.25} = 124 \text{ scfm (211 m³/h)}$

The suitable model for these requirements is **DRYPOINT RAC 125** (with a spec. nominal capacity of 125 scfm [212 m³/h]).

8.6 Connection to the compressed-air system



Danger!
Compressed air!

All works must only be carried out by qualified skilled personnel.
Never work on compressed-air systems which are under pressure.
The operator or the user must ensure that the dryer is never operated with a pressure exceeding the maximum pressure value indicated on the name plate.
Exceeding the maximum operating pressure can be dangerous for the operator but also for the device.

The air temperature and the air flow at the inlet of the dryer must lie within the limit values indicated on the name plate. The connecting lines must be free from dust, iron rust, shards and other contaminations and correspond to the flow rate of the dryer. Should air with a very high temperature be treated, the installation of an aftercooler may be necessary. For the implementation of maintenance works, the installation of a bypass system is recommended.

The dryer was designed in such a manner that vibrations that may occur during operation are limited. Therefore, it is advisable to employ connecting lines (flexible hoses, vibration-inhibiting fittings etc.) which protect the dryer against possible vibrations in the pipework.



Note!

Contaminated intake air!
In the event that the intake air is strongly contaminated (ISO 8573.1 class 3.-3) or poorer quality, we recommend the additional installation of a prefilter (e.g. CLEARPOINT F040), to avoid clogging of the heat exchanger.

8.7 Electrical connections



Danger!
Supply voltage!

The connection to the electric mains should only be carried out by qualified skilled personnel and must correspond to the legal provisions in force in your region.

Prior to connecting the device, please check the name plate to avoid exceeding the indicated values. The voltage tolerance is +/- 10%.

DRYPOINT RAC 10-480 NA dryers are supplied with a power cord and safety plug (two-pole and earth connection). Make sure that suitable fuses or circuit breakers in accordance with the indications on the name plate are available. A residual-current device (RCD) with $I_{\Delta n} = 0.03A$ is suggested. The cross-section of the power supply cable must correspond to the power consumption of the dryer. In this respect, the ambient temperature, the cable laying conditions, the length of the cables and the requirements of the local electricity supplier need to be considered.



Danger!
Supply voltage and missing earth connection!

Important: ensure that the plant is connected to earth.
Do not use plug adapters at the power plug.
Possible replacement of the power plug must only be carried out by a qualified electrician.

8.8 Condensate drain



Danger!
Compressed air and condensate under pressure!

The condensate is discharged at system pressure.



The drain pipe needs to be secured.

Never direct the condensate drain pipe at persons.

The dryer is delivered with an already integrated timed condensate drain or an electronically level-controlled BEKOMAT condensate drain. Connect the condensate drain with a collection system or container by properly screwing it on.

Do not connect the drain with pressurised plants.



Do not discharge the condensate into the environment.
The condensate accumulating in the dryer contains oil particles which were released into the air by the compressor.
Dispose of the condensate in accordance with the local provisions.
It is advisable to install a water-oil separator, to which the total amount of condensate from the compressors, dryers, tanks, filters etc. is supplied.
We recommend ÖWAMAT oil-water separators for dispersed compressor condensate and BEKOSPLIT emulsion-splitting plants for emulsified condensate.

9 Start-up

9.1 Preliminary stages



Note!

Exceeding of the operating parameters!

Ensure that the operating parameters comply with the nominal values indicated on the name plate of the dryer (voltage, frequency, air pressure, air temperature, ambient temperature etc.).

Prior to delivery, this dryer was thoroughly tested, packed and checked. Please verify the soundness of the dryer during the initial start-up and check the perfect functioning during the first operating hours.



The initial start-up must be carried out by qualified personnel.

During the installation and operation of this device, all national regulations regarding electronics and any other federal and state ordinances, as well as local provisions, need to be adhered to.



The operator and the user must ensure that the dryer is not operated without panels.

9.2 Initial start-up



Note!

The dryer **must not be started up more than six times an hour**. Wait at least five minutes prior to every restart.

The user is responsible for the compliance with these provisions. Irreparable damage can be caused by starting up the device too often.



The method below should be applied during the first start-up, after longer downtimes or subsequent to maintenance works.

The start-up must be carried out by certified skilled personnel.

Processing sequence (see Section 11.1 "Control panel")

- Ensure that all steps of the "Installation" chapter have been carried out.
- Ensure that the connection to the compressed-air system is in accordance with the provisions and that the lines are fixed and supported properly.
- Ensure that the condensate drain pipe is fixed in accordance with the provisions and that it is connected with a collection system or a container.
- Ensure that the bypass system (if installed) is open and that the dryer is disconnected from the compressed-air system.
- Ensure that the manual valve of the condensate drainage cycle is open.
- Remove any packaging material and other items which may block the space around the dryer.
- Establish the mains connection (plug into socket).
- Start the dryer by switching on the main switch on the control panel (pos. 1).
- Make sure that the electronic control unit is switched on.
- Ensure that the power consumption complies with the values on the name plate.
- Ensure that the fan runs properly – **wait for the first interventions**.
- Wait until the dew point remains stable.
- Slowly open the air inlet valve.
- Slowly open the air outlet valve.
- Slowly close the central bypass valve of the system (if installed).
- Check the pipes for air leakage.
- Ensure the proper functioning of the condensate drain cycle (wait for the first condensate discharges).



Note!

A DewPoint included in the green operating area of the electronic controller is correct according to the possible working conditions (flow-rate, temperature of the incoming air, ambient temperature, etc.)

During the operation, the refrigerating compressor runs continuously. The dryer needs to be switched on during the entire compressed-air usage time, even if the compressed-air compressor works periodically.

9.3 Shut down and restart



Shut down (see Section 11.1 "Control panel")

- Ensure that the dew point temperature indicated on the electronic control unit is stable.
- Interrupt the compressed-air supply.
- After a few minutes, stop the dryer by switching off the main switch on the control panel (pos. 1).



Restart (see Section 11.1 "Control panel")

- Make sure that the condenser is clean
- Check whether or not voltage is applied at the dryer.
- Start the dryer by switching on the main switch on the control panel (pos. 1).
- Ensure that the electronic control unit is switched on.
- Wait a few minutes and then check, whether or not the dew point temperature indicated on the electronic control unit is stable and whether or not the condensate is drained off at regular intervals.
- Establish the compressed-air supply.

During the operation, the refrigerating compressor runs continuously. The dryer needs to be switched on during the entire compressed-air usage time, even if the compressed-air compressor works periodically.



Note!

A DewPoint included in the green operating area of the electronic controller is correct according to the possible working conditions (flow-rate, temperature of the incoming air, ambient temperature, etc.)



Note!

The dryer **must not be started up more than six times an hour**. Wait at least five minutes prior to every restart.

The user is responsible for the compliance with these provisions. Irreparable damage can be caused when starting up the device too often.

10 Technical data

10.1 Technical data DRYPOINT RAC 10-175 NA -P (1/115/60) UL

| MODEL | RAC xxx NA-P_yy (3) | | | | | | | | | |
|---|---------------------------|--------------|--------------|--------------|--------------|---------------|---------------|---------------|---------------|---------------|
| Air flow rate at nominal condition (1) | 010 | 015 | 020 | 035 | 050 | 075 | 100 | 125 | 150 | 175 |
| | [scfm] | 10 | 15 | 20 | 35 | 75 | 100 | 125 | 150 | 175 |
| | [m ³ /h] | 17 | 25 | 34 | 59 | 127 | 170 | 212 | 255 | 297 |
| | [l/min] | 283 | 425 | 566 | 991 | 1415 | 2830 | 3538 | 4245 | 4953 |
| Pressure DewPoint at nominal condition (1) | 41 (5) | | | | | | | | | |
| | [°F (°C)] | | | | | | | | | |
| Nominal ambient temperature | 100 (38) | | | | | | | | | |
| | [°F (°C)] | | | | | | | | | |
| Min...Max ambient temperature | 34...113 (1...45) | | | | | | | | | |
| | [°F (°C)] | | | | | | | | | |
| Nominal inlet air temperature | 100 (38) max.131 (55) | | | | | | | | | |
| | [°F (°C)] | | | | | | | | | |
| Nominal inlet air pressure | 100 (7) | | | | | | | | | |
| | [psig (barg)] | | | | | | | | | |
| Max. inlet air pressure | 203 (14) | 232 (16) | | | | | | | | |
| | [psig (barg)] | | | | | | | | | |
| Air pressure drop - Δp | 1.9 (0.13) | 4.4 (0.30) | 0.6 (0.04) | 1.3 (0.09) | 2.2 (0.15) | 2.6 (0.18) | 2.2 (0.15) | 3.5 (0.24) | 4.9 (0.34) | 2.8 (0.19) |
| | [psi (bar)] | | | | | | | | | |
| Inlet - Outlet connections | 1/2" | | | | | | | | | |
| | [NPT-F] | | | | | | | | | |
| Refrigerant type | R134 a | | | | | | | | | |
| | | | | | | | | | | |
| Refrigerant quantity (2) | 7 (0.20) | 7.1/2 (0.21) | 7.1/2 (0.21) | 7.3/4 (0.22) | 8.3/4 (0.25) | 11.3/4 (0.33) | 15.1/2 (0.44) | 14.1/2 (0.41) | 17.3/4 (0.50) | 17.3/4 (0.50) |
| | [oz (kg)] | | | | | | | | | |
| Cooling air fan flow | 180 (300) | | | | | | | | | |
| | [cfm (m ³ /h)] | | | | | | | | | |
| Heat Rejection | 1700 (0.49) | 1750 (0.51) | 1850 (0.54) | 2290 (0.67) | 2700 (0.79) | 4950 (1.45) | 6800 (2.00) | 13490 (3.95) | 13700 (4.00) | 13800 (4.05) |
| | [btu/hr (kW)] | | | | | | | | | |
| Standard Power Supply (2) | 1/115/60 | | | | | | | | | |
| | [PhrV/Hz] | | | | | | | | | |
| Nominal electric consumption | 0.19 | 0.20 | 0.21 | 0.29 | 0.30 | 0.45 | 0.70 | 1.00 | 1.05 | 1.10 |
| | [kW] | | | | | | | | | |
| Total input current | 2.5 | 2.6 | 2.7 | 3.2 | 3.4 | 5.1 | 8.0 | 7.6 | 7.7 | 7.7 |
| | [A] | | | | | | | | | |
| Minimum Circuit Ampacity (MCA) | 2.7 | 2.7 | 2.7 | 3.7 | 4.0 | 4.6 | 8.8 | 10.2 | 10.2 | 10.2 |
| | [A] | | | | | | | | | |
| Maximum rating of Overcurrent Protective device (MOP) | 3.4 | 3.4 | 3.4 | 4.6 | 4.9 | 5.6 | 10.8 | 12.6 | 12.6 | 12.6 |
| | [A] | | | | | | | | | |
| Fuse max. | 5.9 | 5.9 | 5.9 | 8.1 | 8.4 | 9.7 | 18.9 | 22.1 | 22.1 | 22.1 |
| | [A] | | | | | | | | | |
| Max. noise level at 1 m | < 70 | | | | | | | | | |
| | [dbA] | | | | | | | | | |
| Weight | 57 (26) | 60 (27) | 62 (28) | 62 (28) | 68 (31) | 84 (38) | 86 (39) | 88 (40) | 90 (41) | 119 (54) |
| | [lb (kg)] | | | | | | | | | |

(1) The nominal condition refers to an ambient temperature of 100°F (38°C) with inlet air at 100 psig (7 barg) and 100°F (38°C).

(2) Check the data shown on the identification plate.

(3) " _yy" can be _JT (Timed drain) or _JB (Bekomat drain)

10.2 Technical data DRYPOINT RAC 125-480 NA -E (1/230/60) UL

| MODEL | RAC xxx NA-E_yy (3) | | 125 | 150 | 175 | 220 | 300 | 375 | 480 |
|---|---------------------|--|-----------------------|---------------|---------------|---------------|---------------|--------------|--------------|
| Air flow rate at nominal condition (1) | [scfm] | | 125 | 150 | 175 | 220 | 300 | 375 | 480 |
| | [m3/h] | | 212 | 255 | 297 | 374 | 509 | 637 | 815 |
| | [l/min] | | 3538 | 4245 | 4953 | 6226 | 8490 | 10613 | 13584 |
| Pressure DewPoint at nominal condition (1) | [°F (°C)] | | 41 (5) | | | | | | |
| Nominal ambient temperature | [°F (°C)] | | 100 (38) | | | | | | |
| Min...Max ambient temperature | [°F (°C)] | | 34...113 (1...45) | | | | | | |
| Nominal inlet air temperature | [°F (°C)] | | 100 (38) max.131 (55) | | | | | | |
| Nominal inlet air pressure | [psig (barg)] | | 100 (7) | | | | | | |
| Max. inlet air pressure | [psig (barg)] | | 203 (14) | | | | | | |
| Air pressure drop - Δp | [psi (bar)] | | 3.5 (0.24) | 4.9 (0.34) | 2.8 (0.19) | 3.6 (0.25) | 2.0 (0.14) | 2.9 (0.20) | 2.2 (0.15) |
| Inlet - Outlet connections | [NPT-F] | | 1.1/4" 2" | | | | | | |
| Refrigerant type | | | R407C | | | | | | |
| Refrigerant quantity (2) | [oz (kg)] | | 14.1/2 (0.41) | 17.3/4 (0.50) | 17.3/4 (0.50) | 24.3/4 (0.70) | 35.1/2 (1.00) | 39 (1.10) | 60 (1.70) |
| Cooling air fan flow | [cfm (m3/h)] | | 220 (380) | 350 (600) | 350 (600) | 530 (900) | 1100 (1900) | 1100 (1900) | 1500 (2500) |
| Heat Rejection | [btu/hr (kW)] | | 12950 (3.80) | 13200 (3.85) | 13300 (3.90) | 17300 (5.05) | 17400 (5.10) | 26600 (7.80) | 27000 (7.90) |
| Standard Power Supply (2) | [Ph/V/Hz] | | 1/230/60 | | | | | | |
| Nominal electric consumption | [kW] | | 1,05 | 1,15 | 1,20 | 1,25 | 1,50 | 2,20 | 2,30 |
| | [A] | | 4,4 | 4,5 | 4,9 | 5,2 | 5,7 | 9,1 | 9,4 |
| Total input current | [A] | | 5,3 | 5,3 | 5,3 | 6,3 | 5,9 | 11,3 | 11,3 |
| Minimum Circuit Ampacity (MCA) | [A] | | 6,5 | 6,5 | 6,5 | 7,5 | 7,1 | 13,8 | 13,8 |
| Maximum rating of Overcurrent Protective device (MOP) | [A] | | 11,2 | 11,2 | 11,2 | 12,2 | 12,0 | 24,1 | 24,1 |
| Fuse max. | [A] | | 10 | 10 | 10 | 12 | 12 | 20 | 20 |
| Max. noise level at 1 m | [dba] | | < 70 | | | | | | |
| Weight | [lb (kg)] | | 88 (40) | 90 (41) | 119 (54) | 123 (56) | 207 (94) | 212 (96) | 317 (144) |

(1) The nominal condition refers to an ambient temperature of 100°F (38°C) with inlet air at 100 psig (7 barg) and 100°F (38°C).

(2) Check the data shown on the identification plate.

(3) "_yy" can be _JT (Timed drain) or _JB (Bekomat drain)

11 Technical description

11.1 Control panel

The control panel explained below is the only dryer user interface.

RAC 10 – 175 NA UL

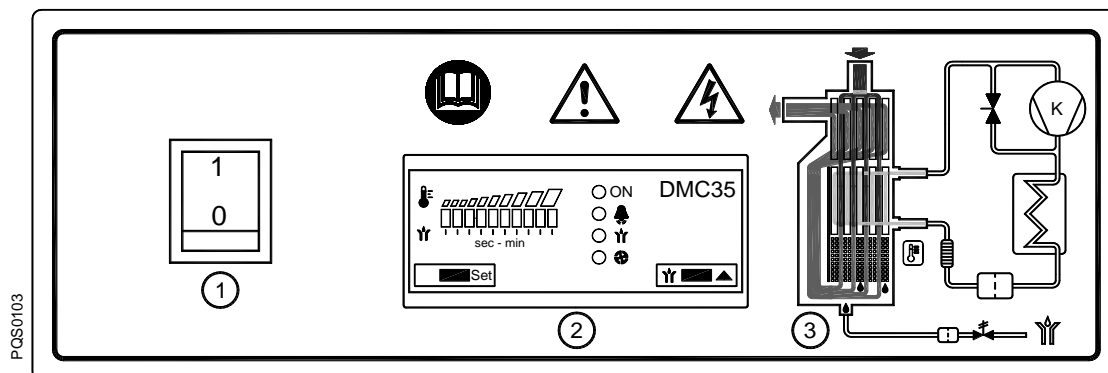

RAC 220 – 480 NA UL

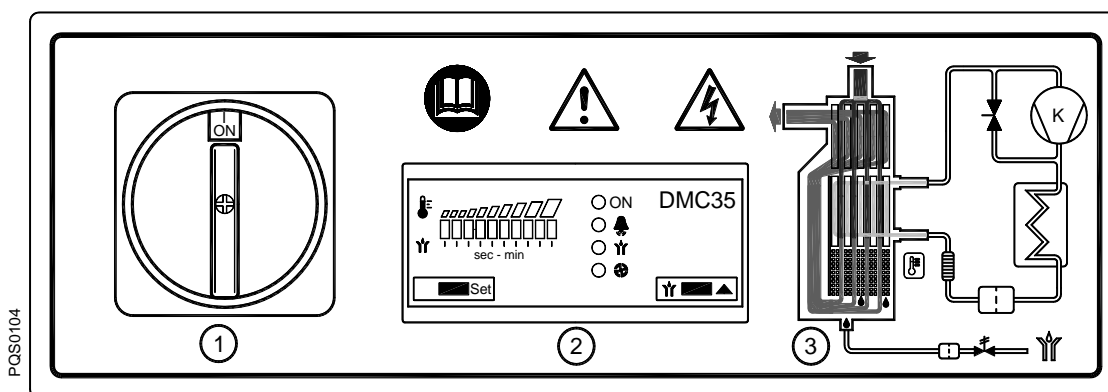

- 1 ON-OFF Switch
- 2 Electronic instrument
- 3 Air and refrigerant flow diagram

11.2 Functional description

Operating principle – All dryer models described in this manual function according to the same principle. The hot and moisture-loaded air is led into an air/air heat exchanger. Afterwards, the air flows through an evaporator, which is also known as an air/refrigerant heat exchanger. The air temperature is reduced to approximately 36°F (2°C), so that water vapour condenses to liquid. The continuously accumulating condensate is collected in the separator to be discharged via the condensate drain. Subsequently, the cold and dry air is led through the air/air heat exchanger, so that it is reheated to up to 46°F (8°C) below the inlet temperature when leaving the dryer.

Refrigeration cycle – The refrigerant is conducted through the compressor and reaches a condenser under high pressure. There, cooling-down takes place, making the refrigerant condense to a liquid state which is under high pressure. The liquid is pressed through a capillary tube where the resulting pressure drop ensures that the refrigerant evaporates at a defined temperature. The liquid refrigerant which is under low pressure is led into the heat exchanger, where it expands. The cold resulting from the expansion serves to cool down the compressed air in the heat exchanger. During this process, the refrigerant evaporates. The low-pressure gas is resupplied to the compressor, where it is compressed again. It then re-enters the cycle. In phases of a reduced compressed-air load, the excess refrigerant is resupplied automatically to the compressor via the hot gas bypass valve.

11.3 Flow chart

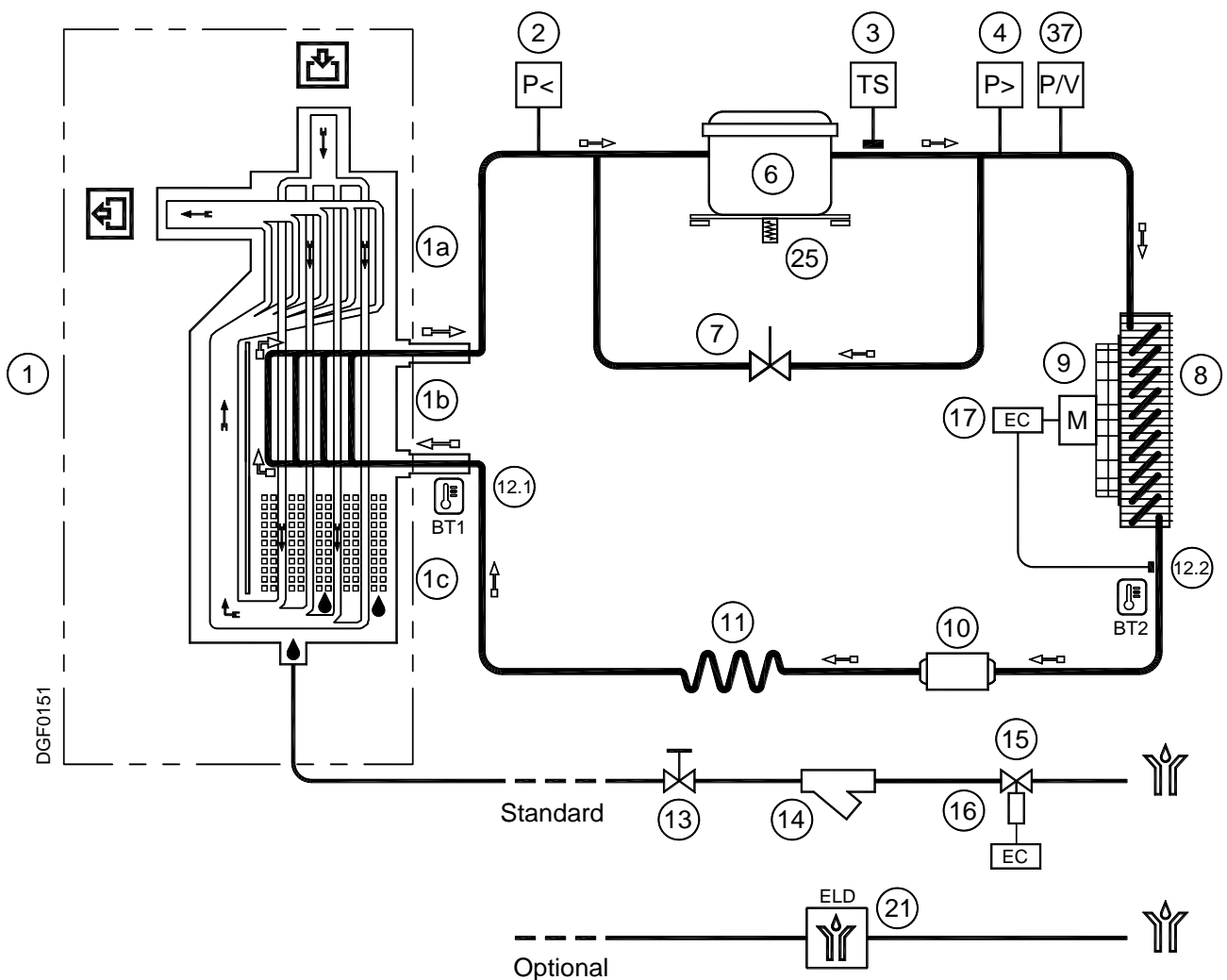

- | | |
|--|---|
| <p>1 Aluminium heat exchanger module</p> <p>a – Air/air heat exchanger</p> <p>b – Air/refrigerant heat exchanger</p> <p>c – Condensate separator</p> <p>2 Refrigerant pressure switch LPS (RAC 480)</p> <p>3 Safety temperature switch TS (RAC 220-480)</p> <p>4 Refrig. pressure switch HPS (RAC 300-480)</p> <p>6 Refrigerating compressor</p> <p>7 Hot-gas bypass valve</p> <p>8 Condenser</p> <p>9 Condenser fan</p> | <p>10 Filter dryer</p> <p>11 Capillary tube</p> <p>12.1 T1 temperature sensor (dew point)</p> <p>12.2 Temperature probe T2 – Fan control (RAC 10-100)</p> <p>13 Condensate drain shut-off valve</p> <p>14 Condensate drain strainer</p> <p>15 Condensate drain solenoid valve</p> <p>16 Coil for condensate drain solenoid valve</p> <p>17 Electronic instrument</p> <p>21 BEKOMAT condensate drain</p> <p>37 Pressure Transducer BP2 – Fan control (RAC125-480)</p> |
|--|---|

➔ Compressed-air flow direction

⇨ Refrigerant gas flow direction

11.4 Refrigerating compressor

The employed refrigerating compressors are constructed by leading manufacturers. The hermetically sealed construction is absolutely gastight. The integrated safeguard protects the compressor against overheating and excess current. The protection is automatically reset as soon as the nominal conditions are reached again.

11.5 Condenser

The condenser is the component in which the gas coming from the compressor is cooled down, condensed and liquefied. Under no circumstances must the temperature of the ambient air exceed the nominal values. It is also important that the condenser unit is kept free from dust and other impurities.

11.6 Filter dryer

Despite controlled vacuuming, traces of moisture can accumulate in the refrigeration cycle. The filter dryer serves to absorb this moisture and to bond it.

11.7 Capillary tube

The capillary tube is a copper tube with a reduced diameter which is located between the condenser and the evaporator, serving as a restrictor to reduce the pressure of the refrigerant. The pressure reduction serves to reach an optimum temperature inside of the evaporator. The lower the outlet pressure at the capillary tube, the lower the evaporation temperature.

The length and the inner diameter of the capillary tube are exactly dimensioned to ensure the performance of the dryer. Settings or maintenance works are not required.

11.8 Aluminium heat exchanger

The heat exchanger module consists of an air/air heat exchanger, an air/refrigerant heat exchanger, and of a high-performance separator. The compressed air flows top-down through the heat exchanger. The large cross-sections of the flow passages cause low flow rates and low compressed-air losses. In the air/air heat exchanger, the heat exchange is effected in a reverse current. This guarantees maximum heat transfer. The heat transfer in the air/refrigerant heat exchanger also takes place in a reverse current. This allows full evaporation of the refrigerant. The high-performance separator ensures almost complete separation of the condensate. Maintenance of the high-performance separator is not required.

11.9 Hot-gas bypass valve

At partial load, the valve directly returns a part of the hot gas to the suction line of the refrigerating compressor. The evaporation temperature and the evaporation pressure remain constant.



ADJUSTMENT

The hot gas by-pass valve is adjusted during the manufacturing testing phase. As a rule no adjustment is required; anyway if it is necessary the operation must be carried out by an experienced refrigerating engineer.

WARNING

the use of 1/4" Schrader service valves must be justified by a real malfunction of the refrigerating system. Each time a pressure gauge is connected, a part of refrigerant is exhausted.

Without compressed air flow through the dryer, rotate the adjusting screw (position A on the drawing) until the following value is reached:

Hot gas setting :

R134.a pressure 29.0 psig (+ 1.45 / -0 psi) [2.0 barg (+0.1 / -0 bar)]

R407C pressure 65.3 psig (+1.45 / -0 psi) [4.5 barg (+0.1 / -0 bar)]

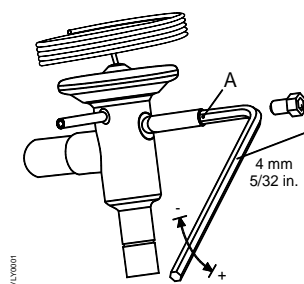

11.10 Refrigerant pressure switches LPS – HPS

To ensure the operational reliability and the protection of the dryer, a series of pressure switches are installed in the gas cycle.

LPS : Low-pressure guard on the suction side of the compressor, which is triggered when the pressure drops below the predetermined value. The values are reset automatically as soon as the nominal conditions are re-established.

Calibrated pressure :

R 407 C Stop 24.7 psig (1.7 barg) - Restart 39.2 psig (2.7 barg)

HPS : The high-pressure control unit on the discharge side of the compressor is activated when the pressure exceeds the predetermined value. It has a manual reset button on the control itself.

Calibrated pressure :

R 407 C Stop 435 psig (30 barg) - Manual reset P<334 psi (P<23 bar)

11.11 Safety temperature switch TS

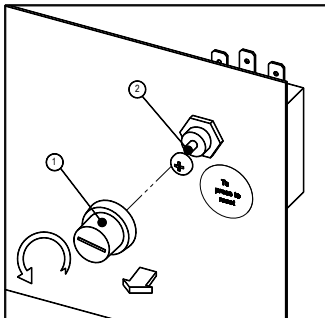

To ensure the operational safety and the soundness of the dryer, a safety temperature switch (TS) is installed at the refrigeration cycle. In the event that the pressure gas temperature is too high, the sensor of the temperature switch will stop the refrigerating compressor to prevent the pressure gas temperature getting too high.

The temperature switch is reset manually, but only when the normal operating conditions are reached again. Unscrew the cover (see pos. 1 in the illustration) and press the reset button (see position 2 in the illustration).

TS setting : temperature 235,4°F (+0/-10°F) [113°C (+0 / -6 °K)]

11.12 Electronic instrument DMC35

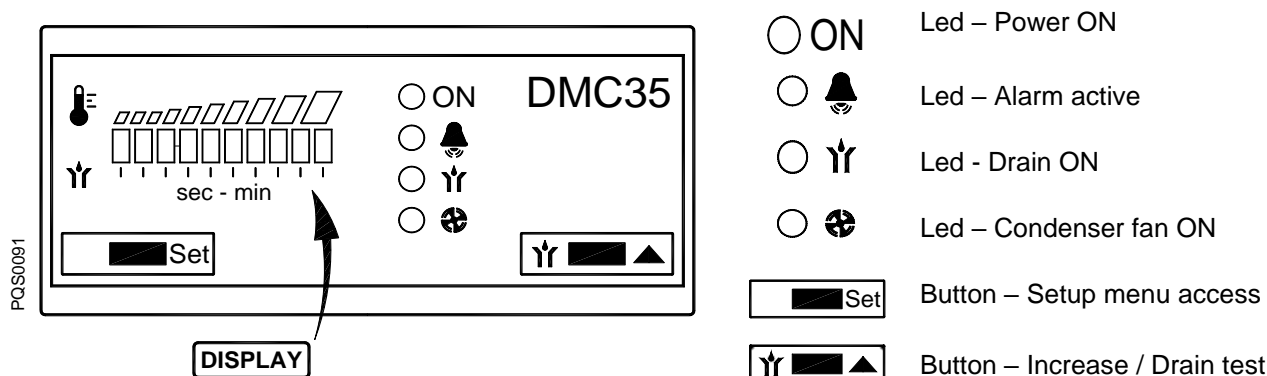

The DMC35 displays DewPoint temperature, controls the condenser fan activation, controls the timed drainer and keep record of the total hours of operation of the dryer.

11.12.1 How to switch on the dryer

Power the dryer and switch it on using the ON-OFF switch (pos.1 paragraph 7.1).

During normal operation led ON is ON and the display shows the DewPoint temperature by means of two coloured areas (green and red) above a 10 Led display :

- Green area - operating conditions ensuring an optimal DewPoint;
- Red area - DewPoint too high, the dryer is operating with high thermal load (high inlet air temperature, high ambient temperature, etc.). Compressed air treatment may be improper.

Led Alarm shows that one or more service warnings / alarms are active.

Led Y shows that condensate drain solenoid valve is ON.

Led Fan shows that condenser fan is ON.

The condensate drain test is always active using the button .

11.12.2 How to switch off the dryer

Switch it off using the ON-OFF switch (pos. 1 paragraph 7.1).

11.12.3 How a service warning / alarm is displayed

A service warning / alarm is an unusual event that must recall the attention of the operators / maintenance technicians. It does not stop the dryer.



Service warnings / alarms are automatically reset as soon as the problem is solved and dryer is powered again.



NOTE: the operator / maintenance technician must inspect the dryer and verify / solve the problem that generated the service warning.

| Service Warning / Alarm | Description |
|--|---|
| Led <input type="radio"/> Alarm and display 1st (left) and 10th (right) led are flashing | Failure BT1 (DewPoint) temperature probe. |
| Led <input type="radio"/> Alarm and led <input type="radio"/> Fan are flashing | Failure BT2/BP2 (fan control) probe. NOTE : fan is forced always ON. |
| Led <input type="radio"/> Alarm and display 1st (left) led are flashing | DewPoint too low (lower than -1°C / 30°F). |

Technical description



11.12.4 How is controlled the condenser fan

RAC10-100 A temperature probe BT2 is located on the discharge side of the condenser. The condenser fan is activated (ON) when the BT2 temperature is higher than FANon setting (approx. 35°C/96°F) and led   is ON. Condenser fan stops when BT2 temperatures is lower than FANoff setting (approx. 30°C/86°F).



RAC125-480 A pressure probe BP2 is located on the discharge side of the compressor. The condenser fan is activated (ON) when the BP2 pressure is higher than FANon setting (approx. 18 barg/260 psig) and led   is ON. Condenser fan stops when BP2 pressure is lower than FANoff setting (approx. 14 barg/203 psig).

11.12.5 How is controlled the drain solenoid valve

Drain solenoid valve is activated (ON) for T_{ON} seconds (standard 2 seconds) every T_{OFF} minutes (standard 1 minute).

Led   shows that condensate drain solenoid valve is ON.

The condensate drain test is always active using the button .



NOTE : if an electronic drainer is installed, DMC35 is set to keep always powered the drain output, Led   is always OFF and condensate drain test does not work.



11.12.6 How to display the total hours of operation

Total hours of operation are recorded into DMC35 and are shown through the dew point indication bar (max value 109900 hours, cannot be reset).

With dryer ON press buttons  and  for at least 5 seconds.

Led  ON is lit and a certain numbers of leds of dew point indication bar are light up. The number of leds lit define the 1st digit of hour counter (ie : no leds lit → 1st digit =0)

Press  button, led   is lit and a certain numbers of leds of dew point indication bar are light up. The number of leds lit define the 2nd digit of hour counter (ie : n.3 leds lit → 2nd digit = 3)

Press  button, led   is lit and a certain numbers of leds of dew point indication bar are light up. The number of leds lit define the 3rd digit of hour counter (ie : n.8 leds lit → 3rd digit = 8)

Total operating hours : 0 3 8 x 100 (fixed multiplying ratio) = 3800 hours

Press  button repeatedly to scroll the displaying of 3 digits again.

Press  button to exit total hours display (if no button is pressed after 30 seconds the menu is exited automatically).

11.12.7 How to change the operating parameters – SETUP menu



The setup menu can be used to change the dryer's operating parameters.



Only qualified personnel must be allowed to access to the setup menu. The manufacturer is not responsible for malfunctioning or failure due to modification to the operating parameters.







With dryer ON press button  for at least 2 seconds to enter the setup menu.

Access to the menu is confirmed by led  ON flashing.



Keep  pressed and use arrows  to change the value. Release the button  to confirm the value.

Press shortly  to skip to following parameter.

Press  to exit setup menu (if no button is pressed after 2 minutes the menu is exited automatically).

| Display | Description | Limits | Resolution | Standard setup |
|--|--|--------------|------------|----------------|
| Synchronous flashing led  ON + led   | T _{ON} – drain time ON : time ON condensate drain valve (1) | 1 ... 6 sec | 1 sec | 2 |
| Non-Synchronous flashing led  ON + led   | T _{OFF} - drain time OFF : pause time for condensate drain valve | 1 ... 10 min | 1 min | 1 |

NOTE : parameter values are displayed on the 10 led display where 1st (left) led is the lowest limit and 10th (right) is the highest limit.

NOTE (1): T_{ON} set at the 10th led (right) keep drain output always powered and led   always off (used if electronic drainer is installed).

11.12.8 Connection to a serial line

The controller can be connected to a serial monitoring line, a remote control or a notebook to read dryer operating data. For further information, please contact your retailer or your service center

11.13 Electronically level-controlled BEKOMAT condensate drain

The electronically level-controlled BEKOMAT condensate drain boasts a special condensate management which ensures that condensate is discharged safely and without an unnecessary loss of compressed air. This drain has a condensate collection container in which a capacitive sensor continuously monitors the liquid level. As soon as the switching level is reached, the capacitive sensor transmits a signal to the electronic control and a membrane solenoid valve opens to discharge the condensate. The BEKOMAT closes before compressed air emerges.



Note!

These BEKOMAT condensate drains were designed in particular for the operation in a **DRYPOINT RAC** refrigeration dryer. The installation in other compressed-air processing systems or the replacement with another drain brand can lead to malfunction. The maximum operating pressure (see name plate) must not be exceeded!

Ensure that the upstream valve is open when the dryer starts operation.

To obtain detailed information regarding drain functions, troubleshooting, maintenance and spare parts, please read the installation and operating instructions of the BEKOMAT condensate drain.

12 Maintenance, troubleshooting, spare parts and dismantling

12.1 Checks and maintenance



Certified skilled personnel

Installation works must exclusively be carried out by authorised and qualified skilled personnel. Prior to undertaking any measures on the DRYPOINT® RAC 10-480 NA UL compressed-air refrigeration dryer, the certified skilled personnel³ shall read up on the device by carefully studying the operating instructions. The operator is responsible for the adherence to these provisions. The respective directives in force apply to the qualification and expertise of the certified skilled personnel.

For safe operation, the device must only be installed and operated in accordance with the indications in the operating instructions. In addition, the national and operational statutory provisions and safety regulations, as well as the accident prevention regulations required for the respective case of application, need to be observed during employment. This applies accordingly when accessories are used.



Danger!

Compressed air!

Risk of serious injury or death through contact with quickly or suddenly escaping compressed air or through bursting and/or unsecured plant components.

Compressed air is a highly dangerous energy source.

Never work on the dryer when the system is under pressure.

Never direct the compressed-air outlet or condensate drain hoses at persons.

The user is responsible for the proper maintenance of the dryer. Non-observance of the instructions in the "Installation" and "Maintenance, troubleshooting, spare parts and dismantling" chapters leads to the expiration of the guarantee. Improper maintenance may result in dangerous situations for the personnel and/or the device.



Danger!

Supply voltage!

Contact with non-insulated parts carrying supply voltage involves the risk of an electric shock resulting in injuries and death.

Only qualified and skilled personnel are authorised to run electrically-operated devices. Prior to undertaking maintenance measures at the device, the following requirements must be met:

Make sure that the power supply is switched off and that the device is off and marked for maintenance measures. Please also ensure that the power supply cannot be re-established during the works.



Prior to carrying out maintenance works at the dryer, switch it off and wait for at least 30 minutes.



Caution!

Hot surfaces!

During operation, several components can reach surface temperatures of more than 140°F (60°C). There is the risk of burns.

All components concerned are installed inside of the closed housing. The housing must only be opened by certified skilled personnel.

Some components can reach high temperatures during operation. Avoid any contact until the system or the component has cooled down.

³ Certified skilled personnel are persons who are authorised by the manufacturer, with experience and technical training, who are well-grounded in the respective provisions and laws and capable of carrying out the required works and of identifying and avoiding any risks during the machine transport, installation, operation and maintenance. Qualified and authorised operators are persons who are instructed by the manufacturer regarding the handling of the refrigeration system, with experience and technical training, and who are well-grounded in the respective provisions and laws.

**DAILY:**

- Check whether the dew point indicated on the electronics is correct.
- Ensure that the condensate drain system functions properly.
- Make sure that the condenser is clean.

EVERY 200 HOURS OR MONTHLY

- Clean the condenser using an air jet (max. 2 bar / 30 psig) inside out. Make sure not to damage the aluminium lamellae of the cooling package.
- Finally, verify the operation of the device.

EVERY 1,000 HOURS OR ANNUALLY

- Verify all screws, clamps and connections of the electric system to make sure that they are fastened securely. Check the device for broken and ruptured cables or cables without insulation.
- Check the refrigeration cycle for signs of oil and refrigerant leaks.
- Measure the current strength and note it down. Ensure that the read values are within the permissible limit values, as indicated in the specification table.
- Check the hose lines of the condensate drain and replace them, if required.
- Finally, verify the operation of the device.

**EVERY 8,000 HOURS**

- Replace BEKOMAT Service Unit.

12.2 Troubleshooting**Certified skilled personnel**

Installation works must exclusively be carried out by authorised and qualified skilled personnel. Prior to undertaking any measures on the DRYPOINT® RAC 10-480 NA UL compressed-air refrigeration dryer, the certified skilled personnel shall read up on the device by carefully studying the operating instructions. The operator is responsible for the adherence to these provisions. The respective directives in force apply to the qualification and expertise of the certified skilled personnel.

For safe operation, the device must only be installed and operated in accordance with the indications in the operating instructions. In addition, the national and operational statutory provisions and safety regulations, as well as the accident prevention regulations required for the respective case of application, need to be observed during employment. This applies accordingly when accessories are used.

**Danger!****Compressed air!**

Risk of serious injury or death through contact with quickly or suddenly escaping compressed air or through bursting and/or unsecured plant components.

Compressed air is a highly dangerous energy source.

Never work on the dryer when the system is under pressure.

Never direct the compressed-air outlet or condensate drain hoses at persons.

The user is responsible for the proper maintenance of the dryer. Non-observance of the instructions in the "Installation" and "Maintenance, troubleshooting, spare parts and dismantling" chapters leads to the expiration of the guarantee. Improper maintenance may result in dangerous situations for the personnel and/or the device.

**Danger!****Supply voltage!**

Contact with non-insulated parts carrying supply voltage involves the risk of an electric shock resulting in injuries and death.

Maintenance, troubleshooting, spare parts and dismantling

Only qualified and skilled personnel are authorised to run electrically-operated devices. Prior to undertaking maintenance measures at the device, the following requirements must be met:

Make sure that the power supply is switched off and that the device is off and marked for maintenance measures. Please also ensure that the power supply cannot be re-established during the works.



Prior to carrying out maintenance works at the dryer, switch it off and wait for at least 30 minutes.



Caution!









Hot surfaces!

During operation, several components can reach surface temperatures of more than 140°F (60°C). There is the risk of burns.

All components concerned are installed inside of the closed housing. The housing must only be opened by certified skilled personnel.

Some components can reach high temperatures during operation. Avoid any contact until the system or the component has cooled down.

| FAULT | POSSIBLE REASON – SUGGESTED MEASURE |
|---|---|
| ◆ The dryer does not start. | ⇒ Check whether or not the dryer is connected with the electric mains. ⇒ Check the electric cabling. |
| ◆ The refrigerating compressor does not work. | ⇒ The internal heat protection of the compressor was activated – wait 30 minutes and then retry. ⇒ Check the electric cabling. ⇒ If installed – replace the internal heat protection and/or the start-up relay and/or the starting capacitor and/or the operating capacitor. activated ⇒ If installed – the HPS pressure switch was – see the corresponding point. ⇒ If installed – the LPS pressure switch was activated – see the corresponding point. ⇒ If installed – the TS safety temperature switch was activated – see the corresponding point. ⇒ If installed – the power contactor KC1 does not work – replace it. ⇒ In the event that the compressor still does not work, replace it. |
| ◆ The fan of the condenser does not work | ⇒ Check the electric cabling. ⇒ The DMC35 electronic instrument is faulty – replace it. ⇒ There is a leak in the refrigeration cycle – contact a BEKO service technician. ⇒ In the event that the fan still does not work, replace it. |
| ◆ Dew point too high. | ⇒ The dryer does not start up – see the corresponding point. ⇒ The BT1 dew point sensor does not record the temperature properly – ensure that the sensor is pushed down to the bottom of the aluminium tube immersion sleeve. ⇒ The refrigerating compressor does not work – see the corresponding point. ⇒ The ambient temperature is too high or the room ventilation insufficient – ensure sufficient ventilation. ⇒ The inlet air is too hot – re-establish the nominal conditions. ⇒ The inlet air pressure is too low – re-establish the nominal conditions. ⇒ The inlet air throughput is higher than the throughput of the dryer – reduce the flow rate - re-establish the nominal conditions. ⇒ The condenser is dirty – please clean it. ⇒ The condenser fan does not work – see the corresponding point. ⇒ The dryer does not discharge the condensate – see the corresponding point. ⇒ The hot-gas bypass valve needs to be re-adjusted – contact a BEKO service technician to have the nominal setting re-established. ⇒ There is a leak in the refrigeration cycle – contact a BEKO service technician. |
| ◆ Dew point too low. | ⇒ The fan is always ON - the yellow LED  of DMC35 electronic instrument is flashing - see specific point ⇒ The ambient temperature is too low –re-establish the nominal conditions. ⇒ The hot-gas bypass valve needs to be re-adjusted – contact a BEKO service technician to have the nominal setting re-established. |
| ◆ Extreme pressure drop in the dryer. | ⇒ The dryer does not discharge the condensate – see the corresponding point. ⇒ The dew point is too low – the condensate is frozen and blocks the air – see the corresponding point. ⇒ Check the flexible connection hoses for obstructions. |

| | |
|--|---|
| ◆ The dryer does not drain the condensate. | ⇒ The condensate drain service valve is closed - open it. ⇒ Condensate strainer is clogged – remove and clean it. ⇒ The drain solenoid valve is jammed – remove and clean it. ⇒ Verify the electric wiring. ⇒ The coil of the drain solenoid valve is failed – replace it. ⇒ Electronic instrument is faulty – replace it. ⇒ The DewPoint is too low - the condensate is frost and blocks the air - see specific point. ⇒ Inlet compressed air pressure is too low and condensate is not drained – restore nominal conditions. ⇒ The BEKOMAT condensate drain does not work properly (see BEKOMAT MANUAL). |
| ◆ Failure during the condensate discharge. | ⇒ The drain solenoid valve is jammed – remove and clean it. ⇒ Try to remove the electric connector on the solenoid valve - if drain stops verify the electric wiring or the electronic instrument is faulty - replace it ⇒ Please read the separate BEKOMAT installation and operating instructions. |
| ◆ Water in the line. | ⇒ The dryer does not start – see the corresponding point. ⇒ If installed - untreated air flows through the bypass unit – close the bypass. ⇒ The dryer does not drain condensate – see the corresponding point. ⇒ Dew point too high – see the corresponding point. |
| ◆ If installed: the HPS high-pressure switch has triggered. | ⇒ Check which of the following reasons is responsible for the triggering: 1. The ambient temperature is too high or the room ventilation insufficient – ensure sufficient ventilation. 2. The condenser is dirty – please clean it. 3. The condenser fan does not work – see the corresponding point. ⇒ Reset the pressure switch by pressing the button on the controller itself – check the proper functioning of the dryer. ⇒ The HPS pressure switch is defective – contact a BEKO service technician for the replacement. |
| ◆ If installed: the LPS low-pressure switch was triggered. | ⇒ There is a leak in the refrigeration cycle – please contact a BEKO service technician. ⇒ The pressure switch is automatically reset as soon as the normal conditions are re-established – check the dryer for proper functioning. |
| ◆ If installed: the TS safety temperature switch was triggered. | ⇒ Check which of the following reasons is responsible for the triggering: Excess thermal load – re-establish the standard operating conditions. The inlet air is too hot – re-establish the nominal conditions. The ambient temperature is too high or the room ventilation insufficient – ensure sufficient ventilation. The condenser unit is dirty – please clean it. The fan does not work – see the corresponding point. The hot-gas bypass valve needs to be re-adjusted – contact a specialist for refrigerating plants to have the nominal calibration re-established. There is a leak in the refrigeration cycle – please contact a BEKO service technician. ⇒ Reset the temperature switch by manually pushing the button on the temperature switch – check the perfect functioning of the dryer. ⇒ The TS temperature switch is defective – replace it. |
| ◆ DMC35 - Led   and display 1st (left) and 10th (right) led are flashing. | ⇒ Verify the electric wiring of BT1 DewPoint probe. ⇒ The BT1 DewPoint probe is faulty - replace it. ⇒ The electronic instrument is faulty - replace it. |
| ◆ DMC35 Led   and led   are flashing | ⇒ Verify the electric wiring of BT2/BP2 fan control probe. ⇒ The BT2/BP2 fan control probe is faulty - replace it. ⇒ The electronic instrument is faulty - replace it. |
| ◆ DMC35 Led   and display 1st (left) led are flashing | ⇒ DewPoint too low - see specific point. ⇒ The BT1 DewPoint probe is faulty - replace it. ⇒ The electronic instrument is faulty - replace it. |
| ◆ DMC35 Display 10th (right) led is flashing | ⇒ DewPoint too high - see specific point. ⇒ The BT1 DewPoint probe is faulty - replace it. ⇒ The electronic instrument is faulty - replace it. |

Maintenance, troubleshooting, spare parts and dismantling

12.3 Recommended spare-parts

Spare parts list is printed on a dedicated sticker applied inside the dryer. On this sticker each spare part is identified with its ID Number and related Spare Part Number. Here below the cross-reference table between ID Numbers and exploded drawings Ref. with their description and quantity installed in the dryers.

NOTE: To order the recommended spare parts or other elements, the data on the name plate must be indicated.

| ID N. | | DESCRIPTION | DP RAC NA UL 1/115/60 | | | | | | | | | |
|-------|-------|--|-----------------------|----|----|----|----|----|-----|-----|-----|-----|
| | | | 10 | 15 | 20 | 35 | 50 | 75 | 100 | 125 | 150 | 175 |
| 6 | MC | Compressor | 1 | 1 | 1 | 1 | 1 | 1 | 1 | 1 | 1 | 1 |
| 7 | | Hot gas by-pass valve | 1 | 1 | 1 | 1 | 1 | 1 | 1 | 1 | 1 | 1 |
| 9.1 | MV | Fan motor | 1 | 1 | 1 | 1 | 1 | 1 | 1 | 1 | 1 | 1 |
| 9.2 | | Fan blade | 1 | 1 | 1 | 1 | 1 | 1 | 1 | 1 | 1 | 1 |
| 9.3 | | Fan grid | | | | | 1 | 1 | 1 | 1 | 1 | 1 |
| 10 | | Filter drier | 1 | 1 | 1 | 1 | 1 | 1 | 1 | 1 | 1 | 1 |
| 12 | BT1 | Temperature probe | 2 | 2 | 2 | 2 | 2 | 2 | 2 | 1 | 1 | 1 |
| 13-14 | | Condensate drain valve/strainer | 1 | 1 | 1 | 1 | 1 | 1 | 1 | 1 | 1 | |
| 14 | | Y strainer | | | | | | | | | | 1 |
| 15 | EVD | Condensate drain solenoid valve | 1 | 1 | 1 | 1 | 1 | 1 | 1 | 1 | 1 | 1 |
| 16 | | Coil for condensate drain solenoid valve | 1 | 1 | 1 | 1 | 1 | 1 | 1 | 1 | 1 | 1 |
| 17 | DMC35 | Electronic instrument | 1 | 1 | 1 | 1 | 1 | 1 | 1 | 1 | 1 | 1 |
| 21 | ELD | BEKOMAT condensate drain | 1 | 1 | 1 | 1 | 1 | 1 | 1 | 1 | 1 | 1 |
| | | BEKOMAT service unit | 1 | 1 | 1 | 1 | 1 | 1 | 1 | 1 | 1 | 1 |
| 22 | S1 | Lighted switch | 1 | 1 | 1 | 1 | 1 | 1 | 1 | 1 | 1 | 1 |
| 37 | | Pressure transducer | | | | | | | | 1 | 1 | 1 |

| ID N. | | DESCRIPTION | DP RAC NA UL 1/230/60 | | | | |
|-------|-------|--|-----------------------|-----|-----|-----|-----|
| | | | 175 | 220 | 300 | 375 | 480 |
| 2 | LPS | Pressure switch | | | | | 1 |
| 3 | TS | Safety thermo switch | | 1 | 1 | 1 | 1 |
| 4 | HPS | Pressure switch | | | 1 | 1 | 1 |
| 6 | MC | Compressor | 1 | 1 | 1 | 1 | 1 |
| 7 | | Hot gas by-pass valve | 1 | 1 | 1 | 1 | 1 |
| 9 | MV | Complete fan | | | 1 | 1 | 1 |
| 9.1 | | Fan motor | 1 | 1 | | | |
| 9.2 | | Fan blade | 1 | 1 | | | |
| 9.3 | | Fan grid | 1 | 1 | | | |
| 10 | | Filter drier | 1 | 1 | 1 | 1 | 1 |
| 12 | BT1 | Temperature probe | 1 | 1 | 1 | 1 | 1 |
| 14 | | Y strainer | 1 | 1 | 1 | 1 | 1 |
| 15 | EVD | Condensate drain solenoid valve | 1 | 1 | 1 | 1 | 1 |
| 16 | | Coil for condensate drain solenoid valve | 1 | 1 | 1 | 1 | 1 |
| 17 | DMC35 | Electronic instrument | 1 | 1 | 1 | 1 | 1 |
| 21 | ELD | BEKOMAT condensate drain | 1 | 1 | 1 | 1 | 1 |
| | | BEKOMAT service unit | 1 | 1 | 1 | 1 | 1 |
| 22 | S1 | Lighted switch | 1 | | | | |
| | QS | Main switch | | 1 | 1 | 1 | 1 |
| | KC1 | Power Contactor | 1 | 1 | 1 | 1 | 1 |
| 37 | | Pressure transducer | 1 | 1 | 1 | 1 | 1 |

12.5 Maintenance works at the refrigeration cycle



Caution! Refrigerant!

Maintenance and repair works at refrigeration systems must only be carried out by BEKO service technicians in accordance with the local provisions.

The total amount of refrigerant in the system must be collected for recycling purposes, resource recovery or disposal.

The refrigerant must not be discharged into the environment.

When delivered, the dryer is ready to operate and filled with a refrigerant of the R134a or R407C type.



Should you detect a refrigerant leak, please contact a BEKO service technician. Prior to any intervention, the room needs to be ventilated.

When the refrigeration cycle needs to be refilled, please also contact a BEKO service technician.

You will find the refrigerant type and amount on the name plate of the dryer.

Properties of the refrigerants used:

| Refrigerant | Chemical formula | MIK | GWP |
|-------------|---|----------|---------|
| R134a - HFC | CH ₂ FCF ₃ | 1000 ppm | 1430 |
| R407C - HFC | R32/125/134a (23/25/52) CHF ₂ CF ₃ /CH ₂ F ₂ /CH ₂ FCF ₃ | 1000 ppm | 1773,85 |

12.6 Dismantling the dryer

When the dryer is dismantled, all parts and operating materials related to the plant need to be disposed of separately.



| Component | Material |
|--------------------------|--|
| Refrigerant | R407C, R134a, oil |
| Roof and supports | Structural steel, epoxy paint coat |
| Refrigerating compressor | Steel, copper, aluminium, oil |
| Aluminium heat exchanger | Aluminium |
| Condenser unit | Aluminium, copper, structural steel |
| Pipe | Copper |
| Fan | Aluminium, copper, steel |
| Valve | Brass, steel |
| BEKOMAT condensate drain | PVC, aluminium, steel |
| Insulant | Synthetic rubber without CFCs, polysterene, polyurethane |
| Electric cable | Copper, PVC |
| Electric parts | PVC, copper, brass |



We recommend observing the safety provisions in force for the disposal of each material type.

The refrigerant contains lubricating-oil droplets which are released by the compressor.

The refrigerant must not be discharged into the environment. It must to be sucked off from the dryer using a suitable device, and then needs to be supplied to a collection point.

13 Appendices

13.1 Dryer dimensions

13.1.1 Dryer dimensions DRYPOINT RAC 10-15 NA UL

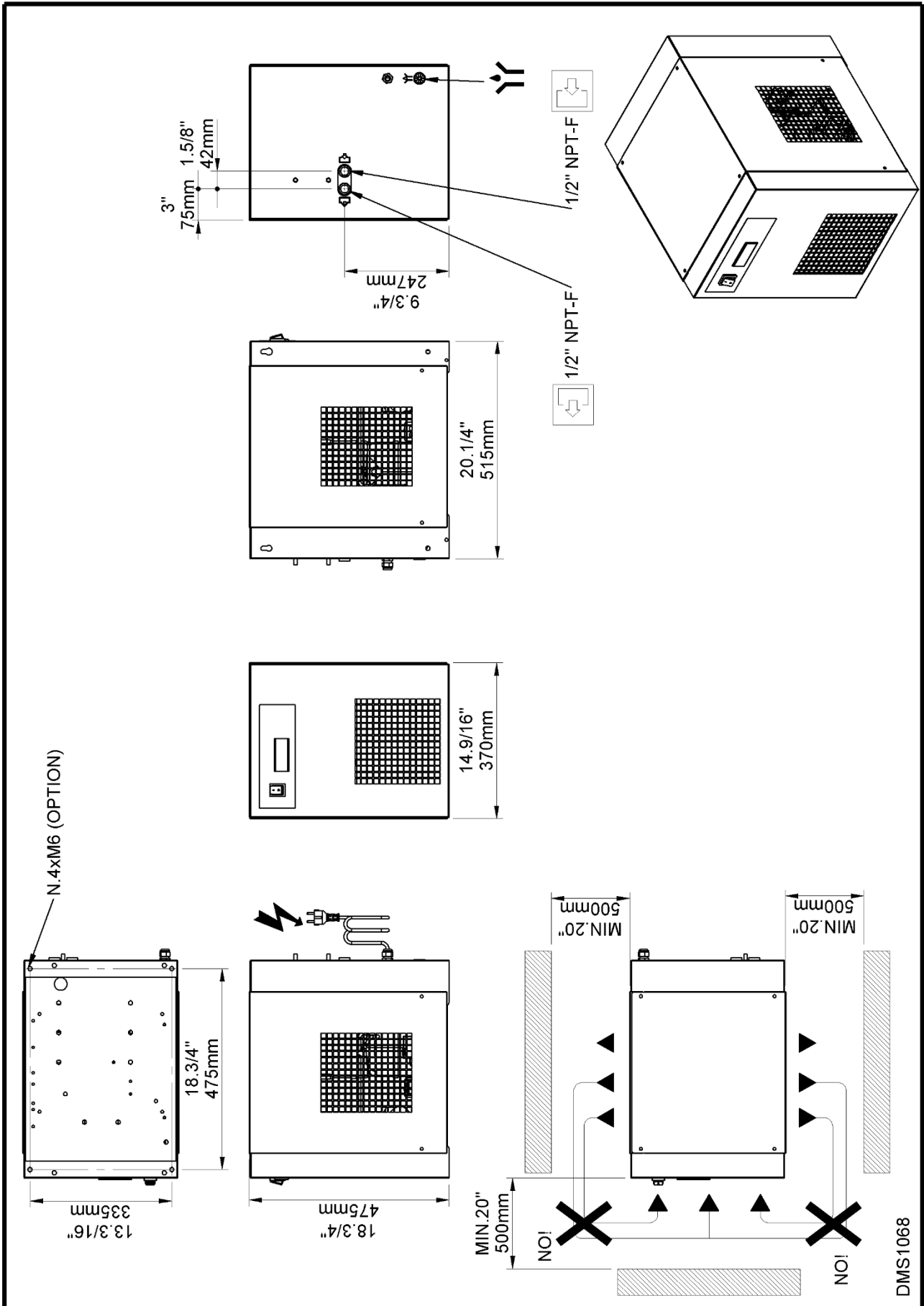

13.1.2 Dryer dimensions DRYPOINT RAC 20-50 NA UL

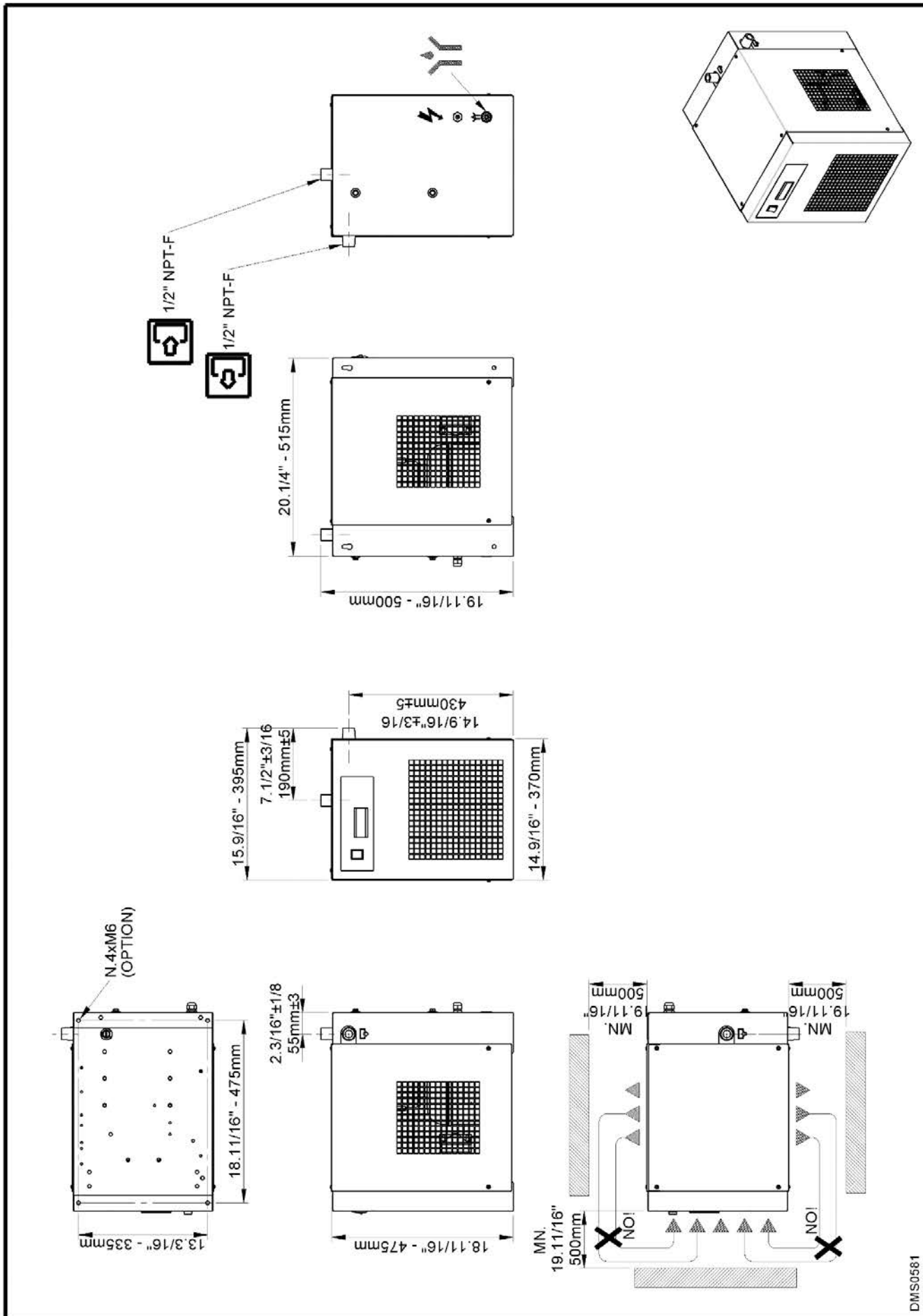

DMS0581

13.1.3 Dryer dimensions DRYPOINT RAC 75 NA UL

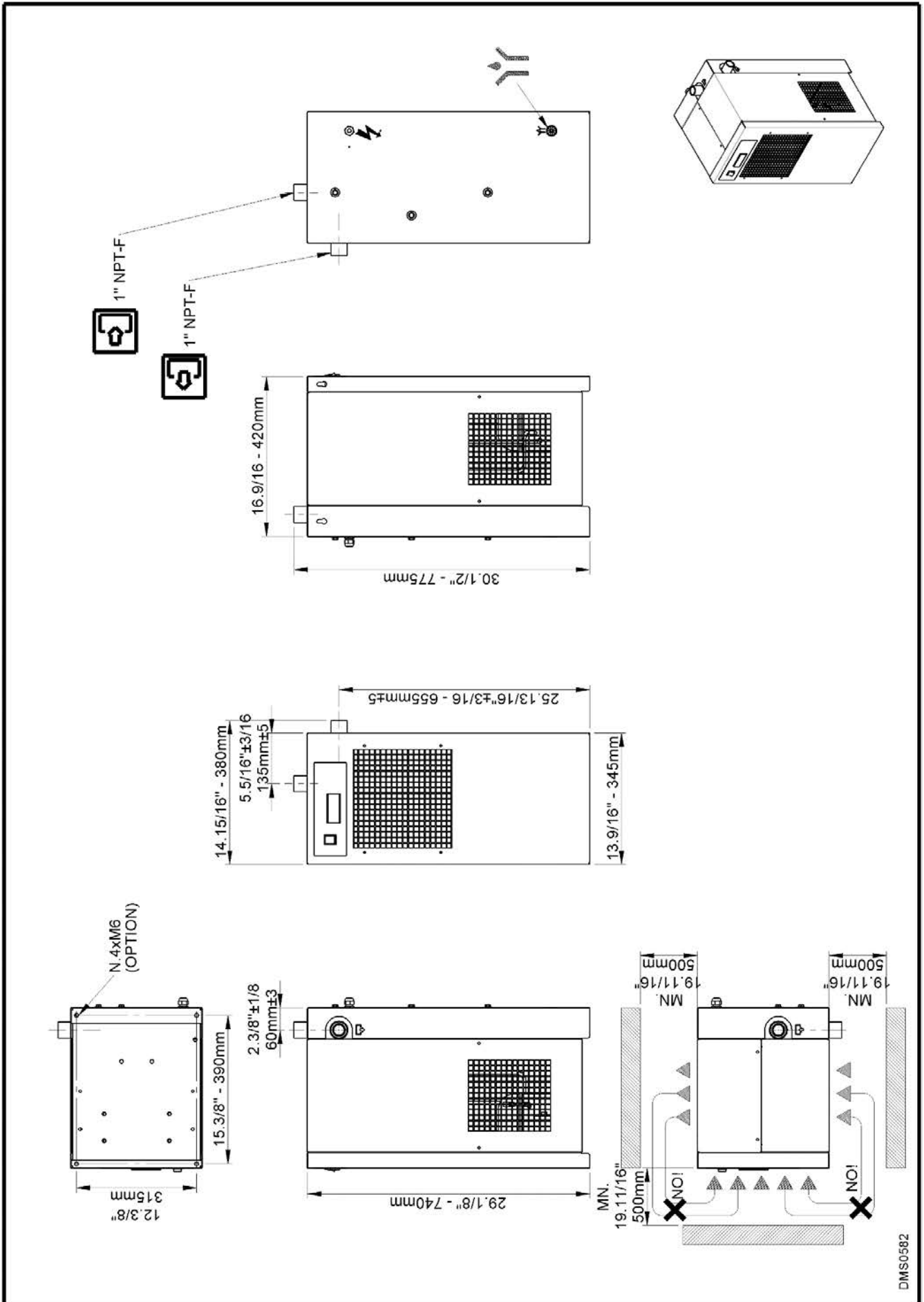

DMS0562

13.1.4 Dryer dimensions DRYPOINT RAC 100-125 NA UL

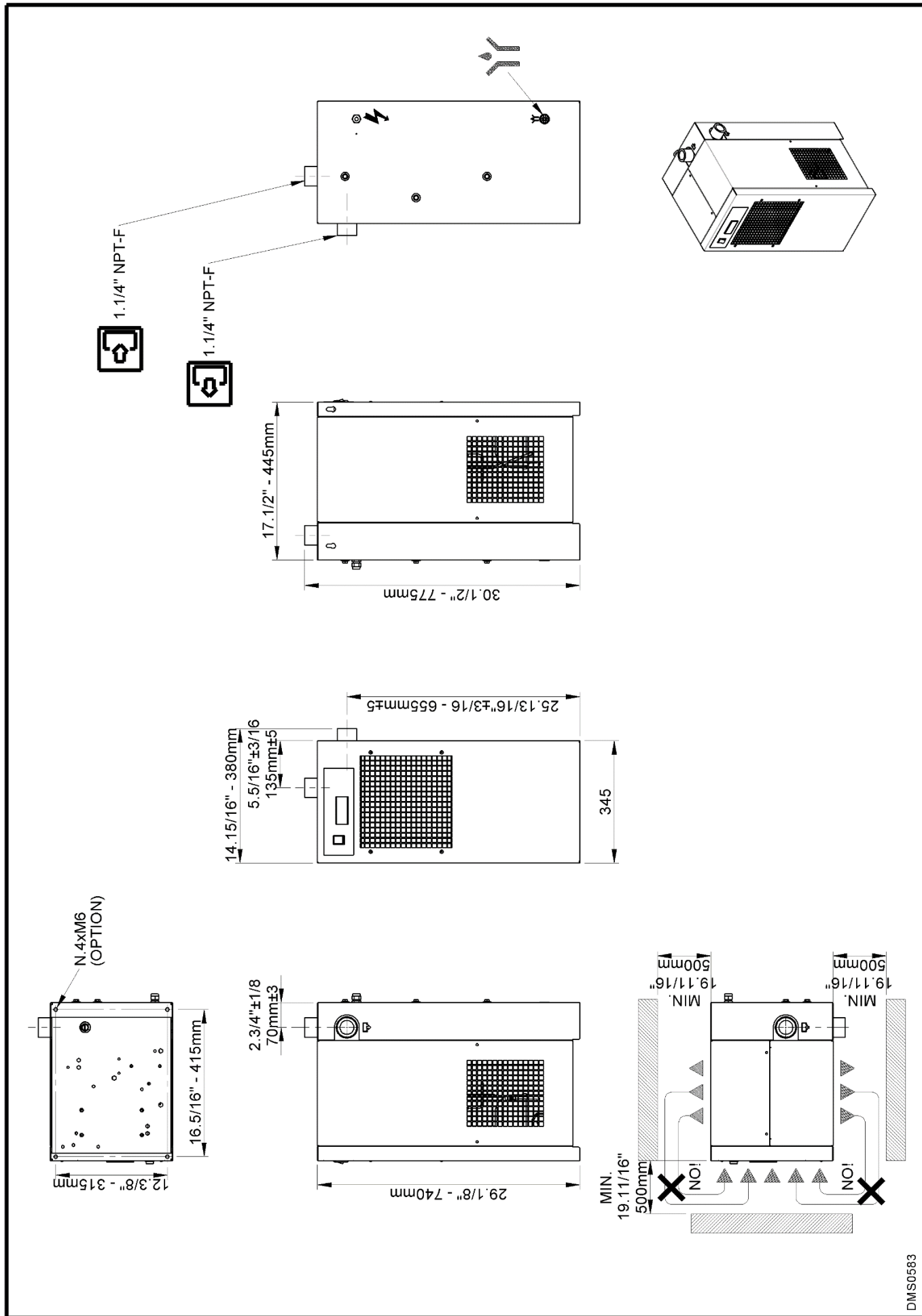

DMS0563

13.1.5 Dryer dimensions DRYPOINT RAC 150 NA UL

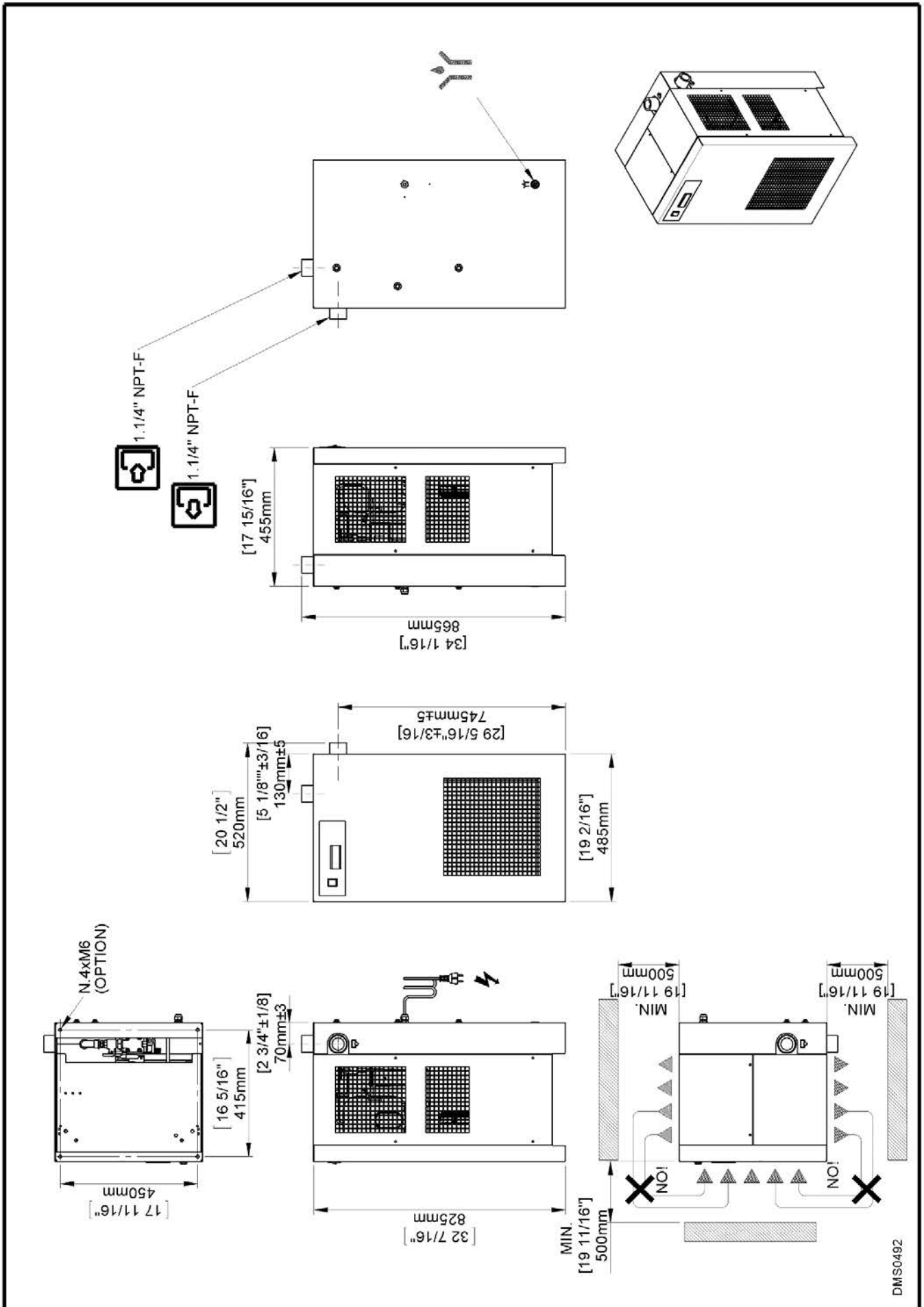

13.1.7 Dryer dimensions DRYPOINT RAC 300-375 NA UL

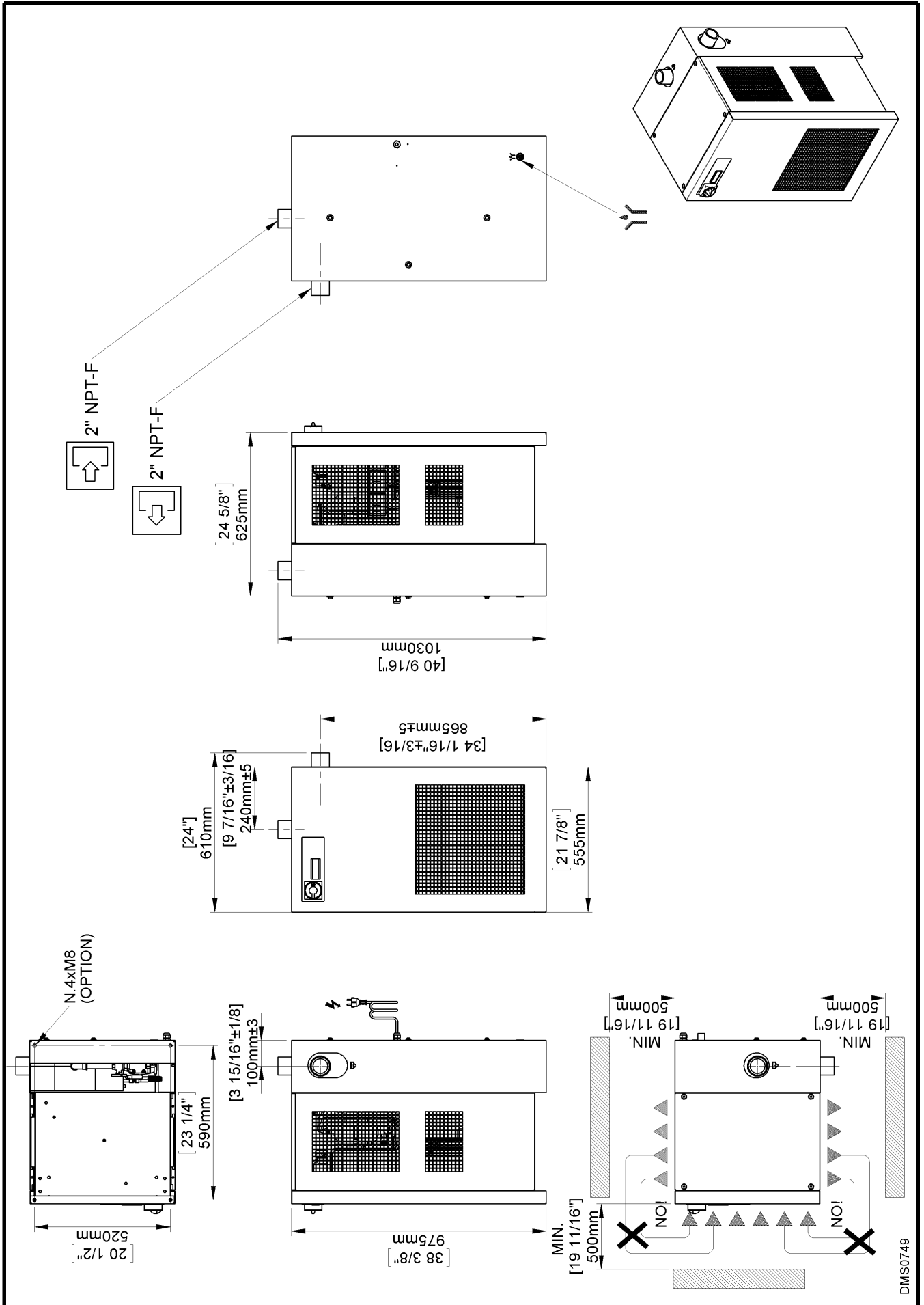

13.1.8 Dryer dimensions DRYPOINT RAC 480 NA UL

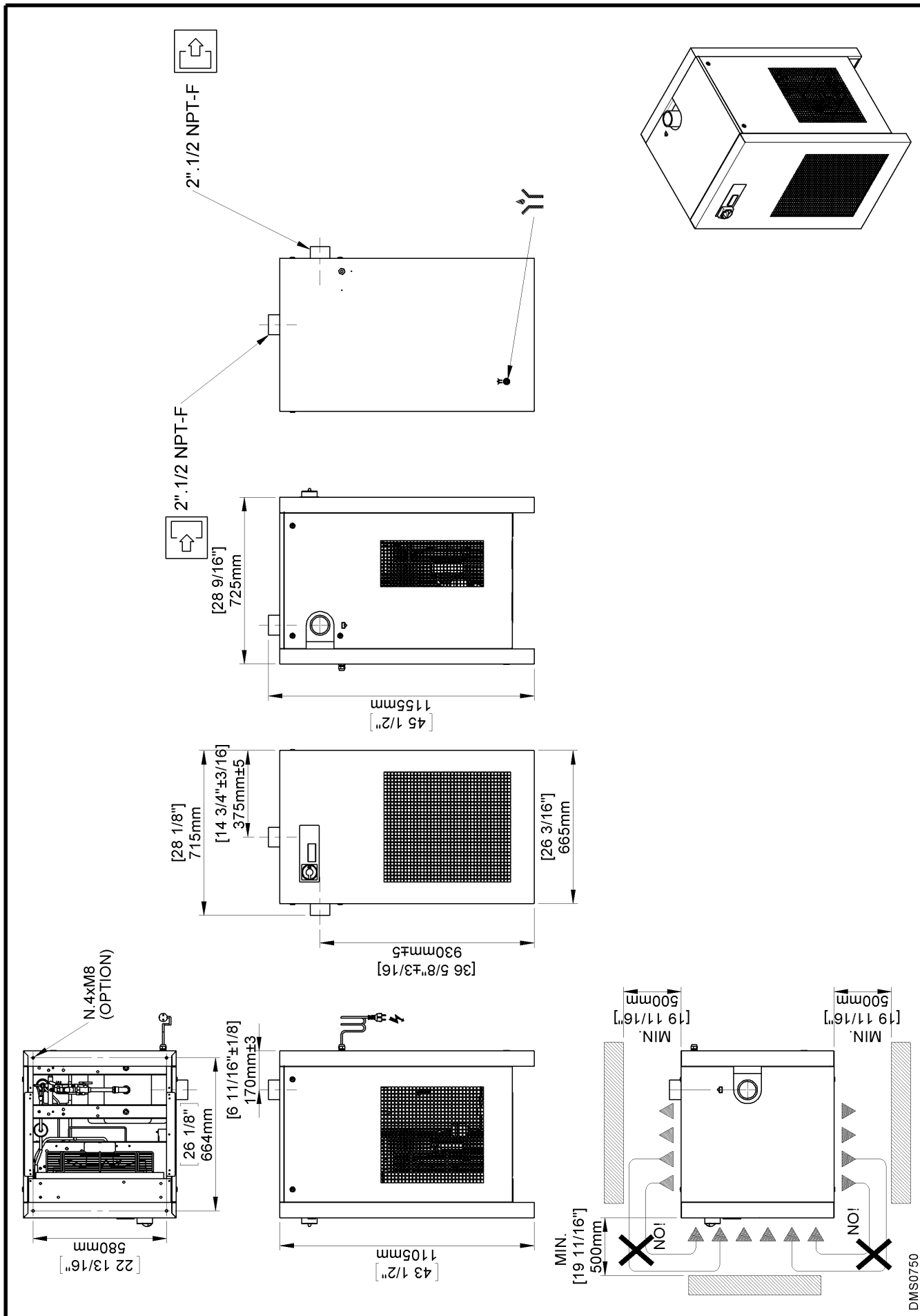

13.2.1 Components of the exploded diagrams

| | | | |
|-----------|------------------------------------|-----------|--|
| 1 | Alu drying module | 16 | Coil for condensate drain solenoid valve |
| | 1.1 Insulation material | 17 | Air dryer control |
| 2 | Refrigerant pressure switch LPS | 21 | Bekomat drain |
| 3 | Safety temperature switch TS | 22 | Main switch |
| 4 | Refrigerant pressure switch HPS | 37 | Pressure transducer BP2 |
| 5 | Refrigerant fan pressure switch PV | 51 | Front panel |
| 6 | Compressor | 52 | Back plate |
| 7 | Hot-gas bypass valve | 53 | Right sidewall |
| 8 | Condenser | 54 | Left sidewall |
| 9 | Condenser fan | 55 | Cover |
| | 9.1 Motor | 56 | Base plate |
| | 9.2 Blade | 57 | Upper plate |
| | 9.3 Grid | 58 | Carrier support |
| 10 | Filter dryer | 59 | Support bracket |
| 11 | Capillary tube | 60 | Control panel |
| 12 | BT1 temperature probe (dew point) | 61 | Electric connecting plug |
| 13 | Condensate drain service valve | 62 | Electric cabinet |
| 14 | Condensate drain strainer | 65 | Condenser filter |
| 15 | Condensate drain solenoid valve | 81 | Adhesive label flow chart |

13.2.2 Exploded diagram DRYPOINT RAC 10-15 NA UL

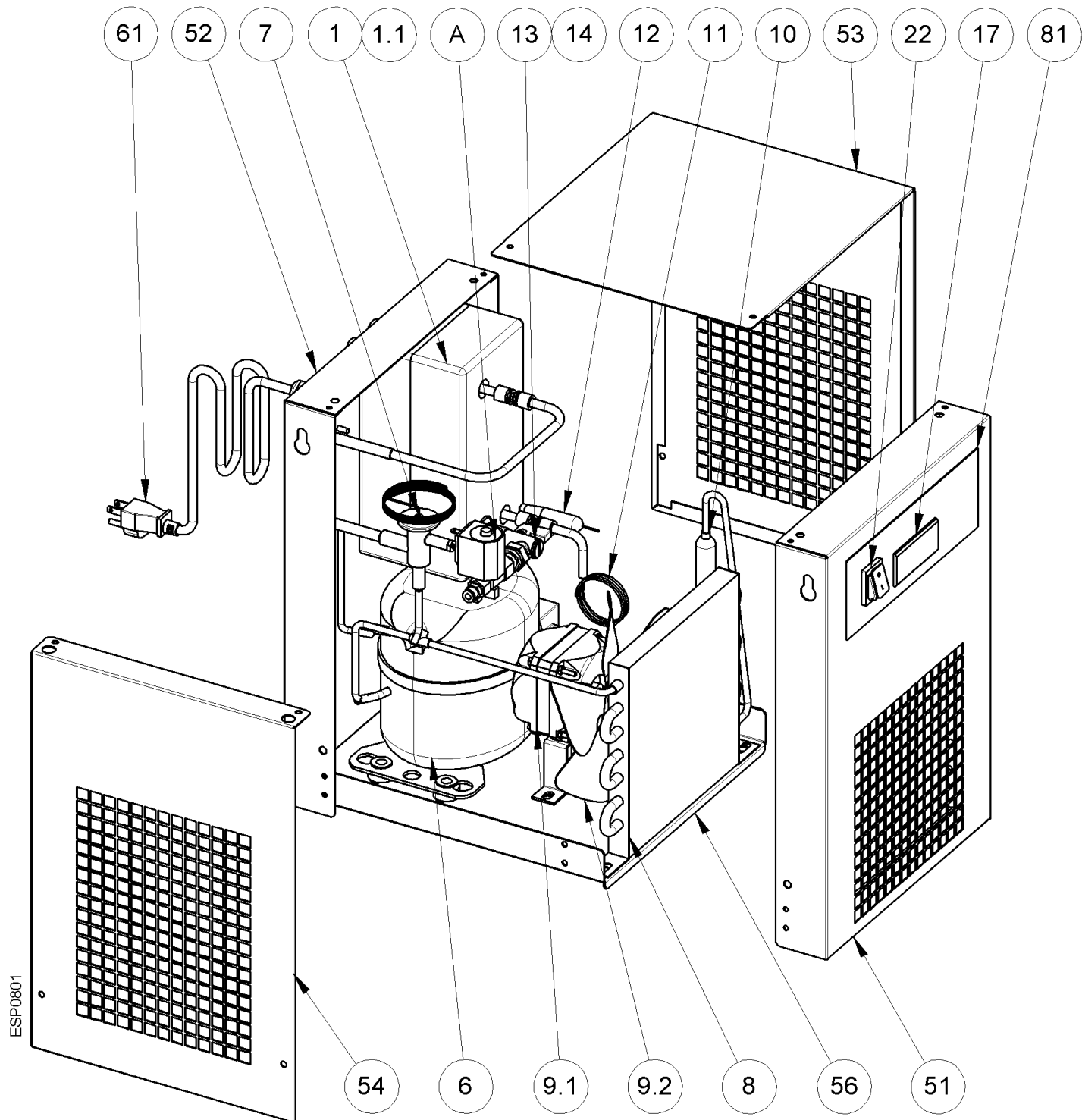

Pos. A standard

Pos. A optional

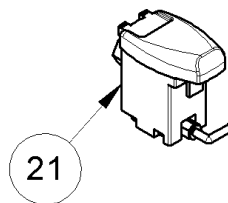
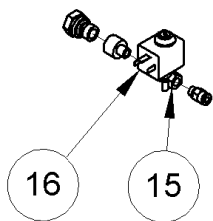

13.2.3 Exploded diagram DRYPOINT RAC 20-35 NA UL

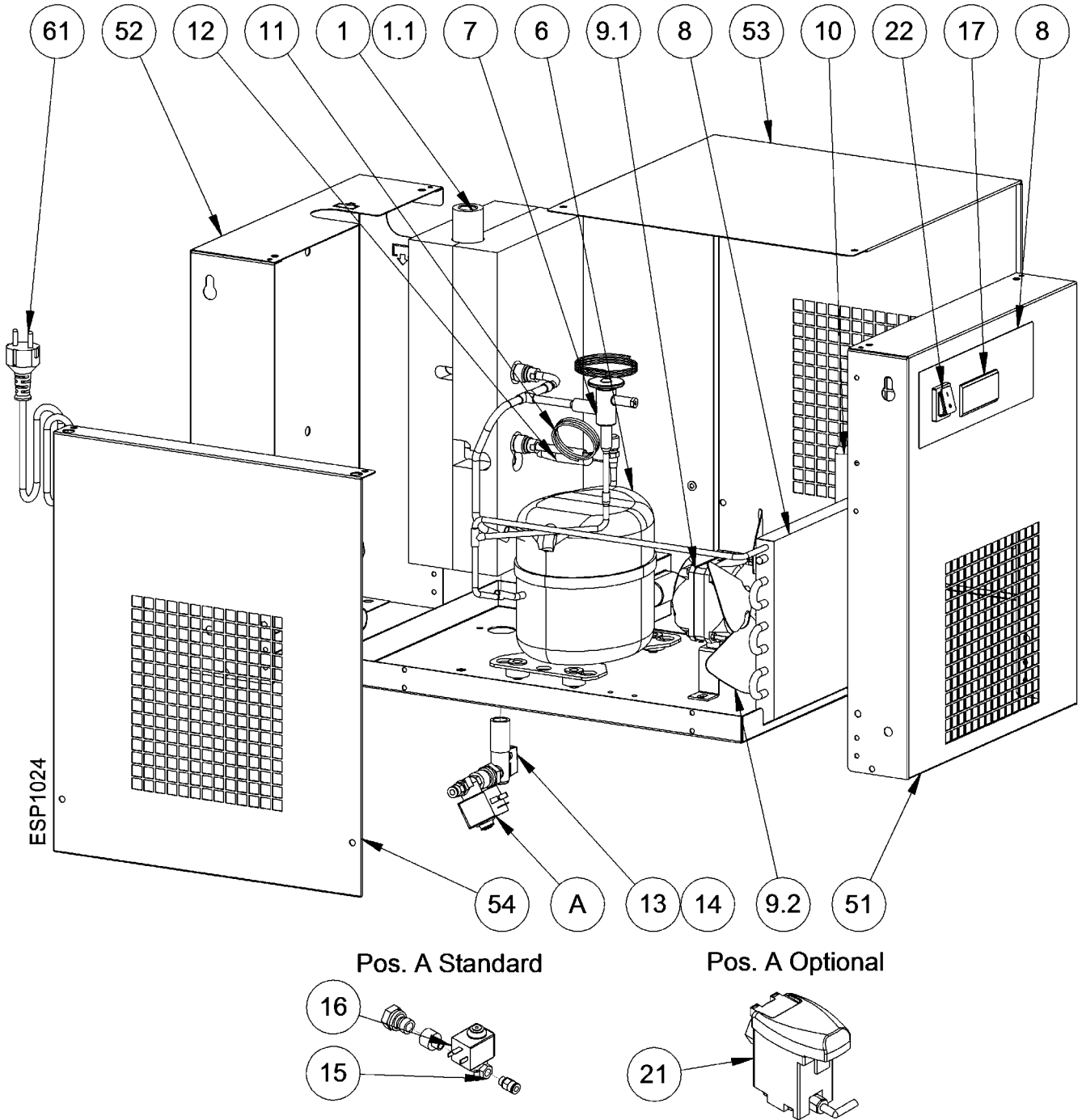

13.2.4 Exploded diagram DRYPOINT RAC 50 NA UL

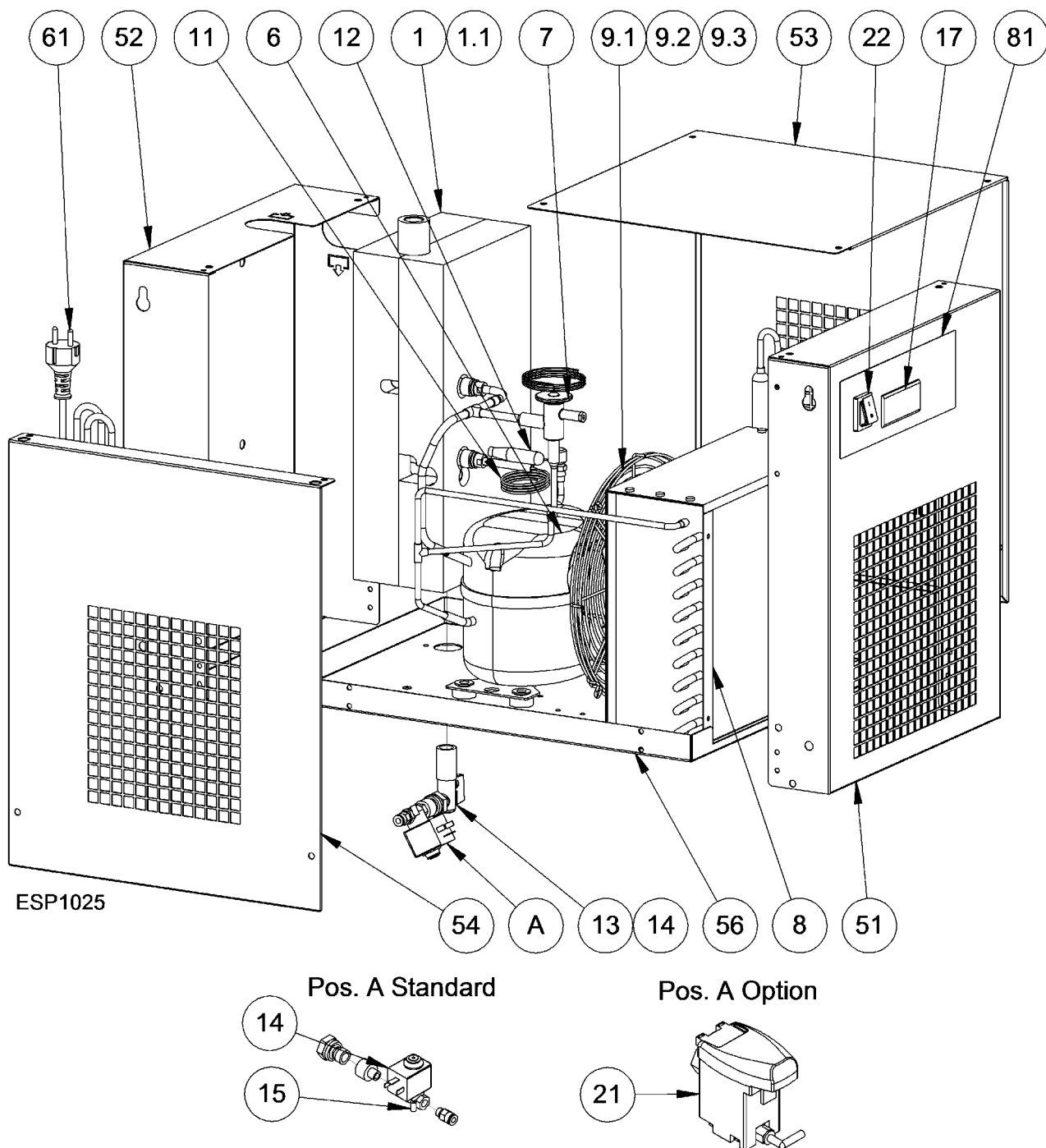

13.2.5 Exploded diagram DRYPOINT RAC 75-100 NA UL

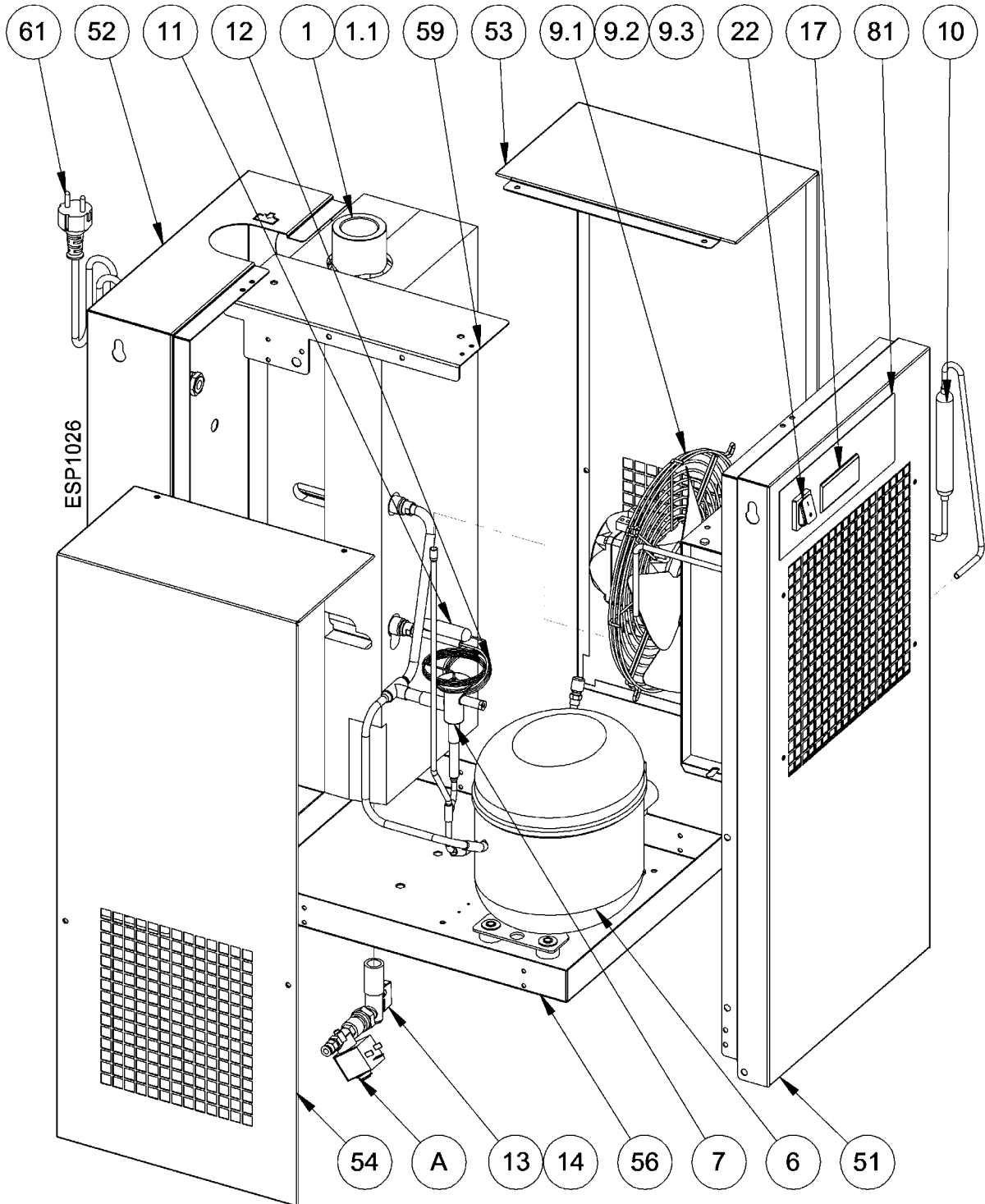

Pos. A Standard

Pos. A Optional

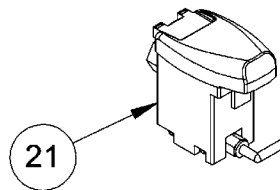
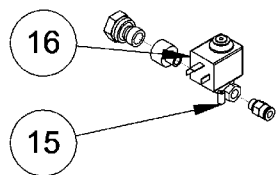

13.2.6 Exploded diagram DRYPOINT RAC 125 NA UL

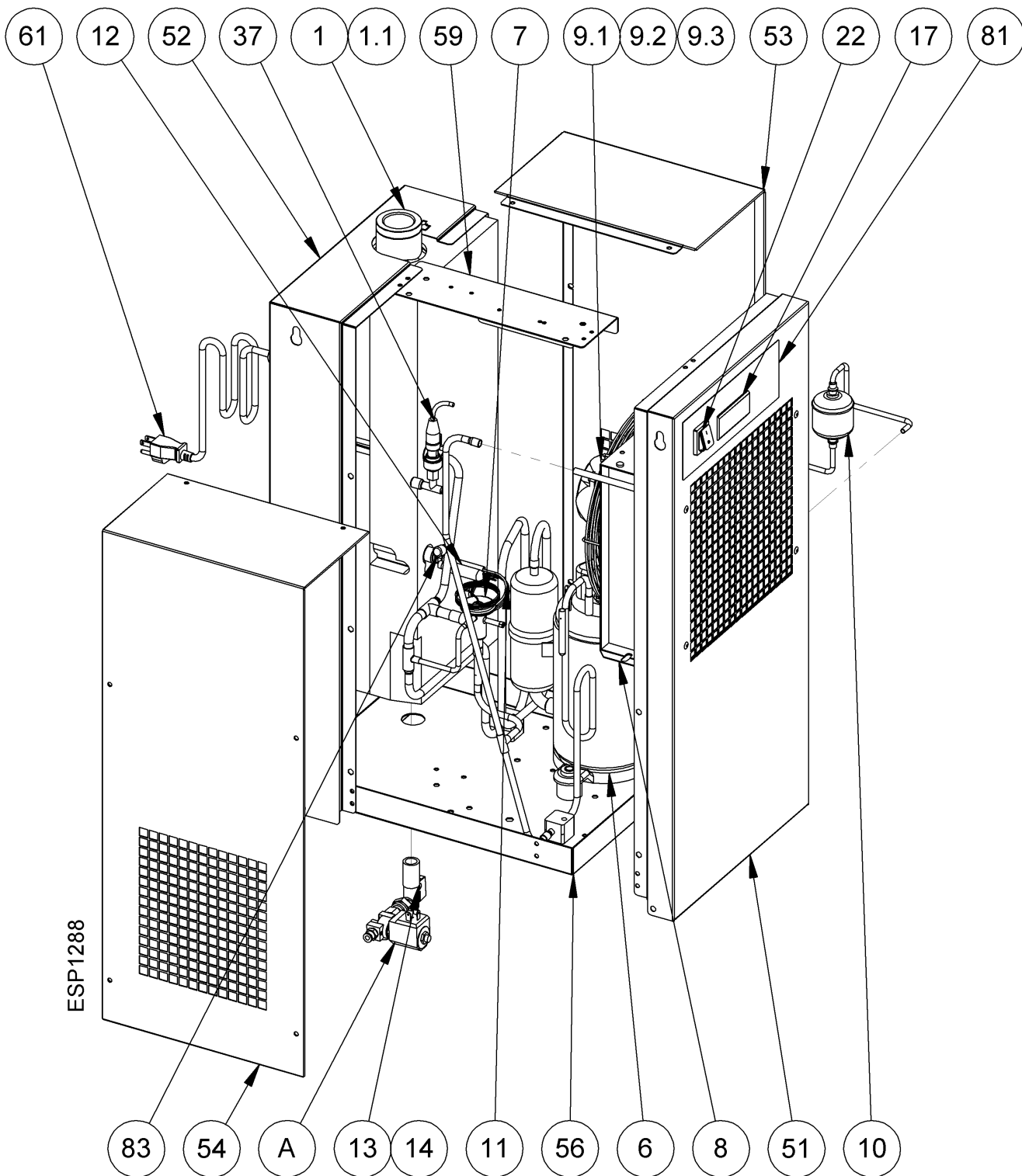

Pos.A Timed

Pos.A Optional

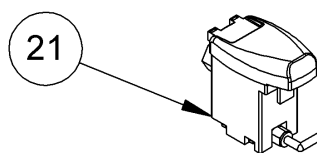
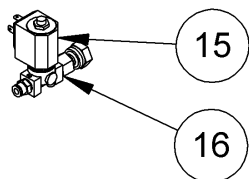

13.2.7 Exploded diagram DRYPOINT RAC 150 NA UL

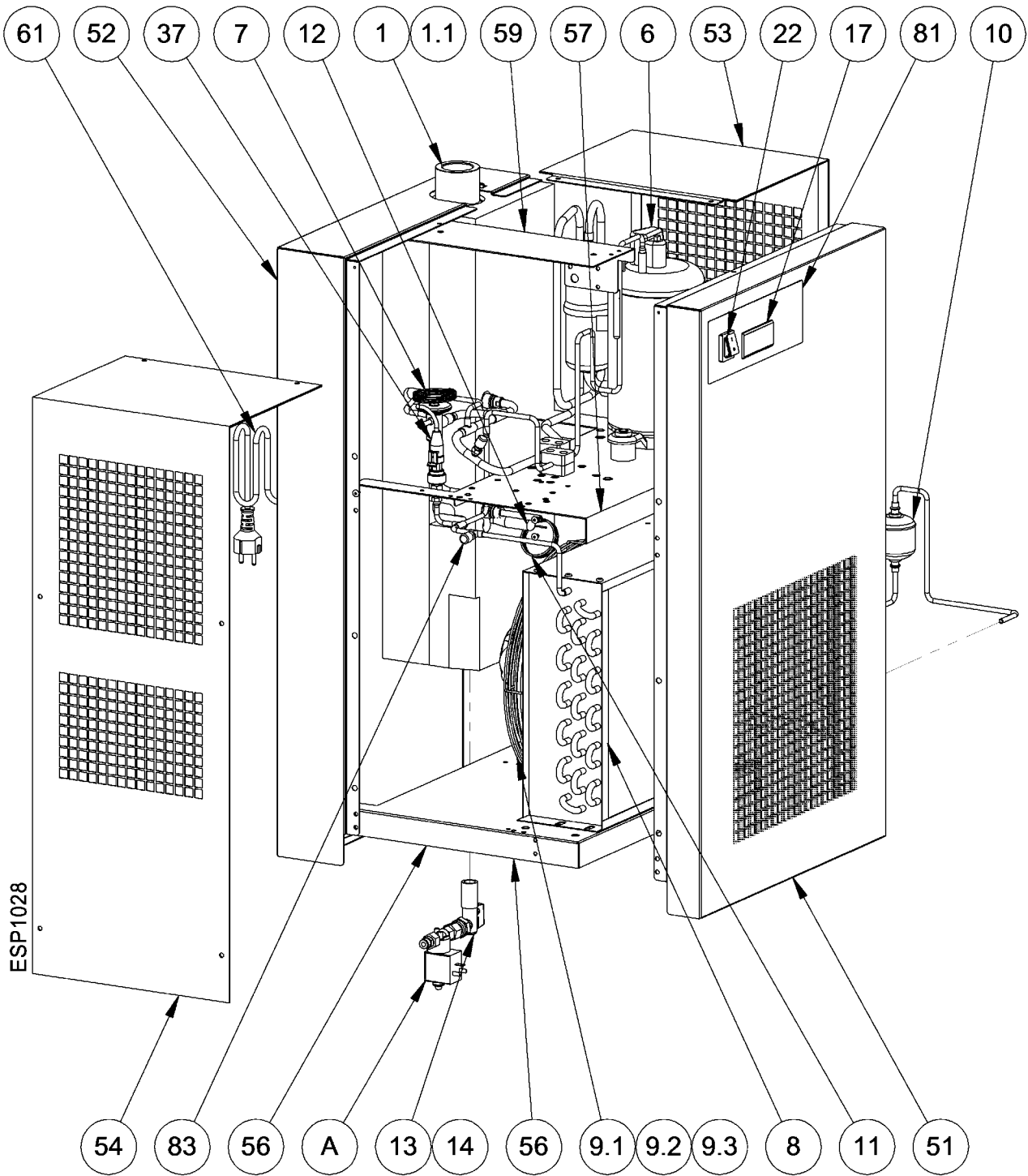

Pos. A Standard

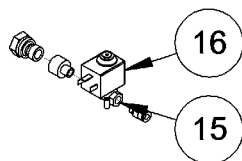

Pos. A Option

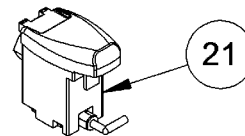

13.2.8 Exploded diagram DRYPOINT RAC 175-220 NA UL

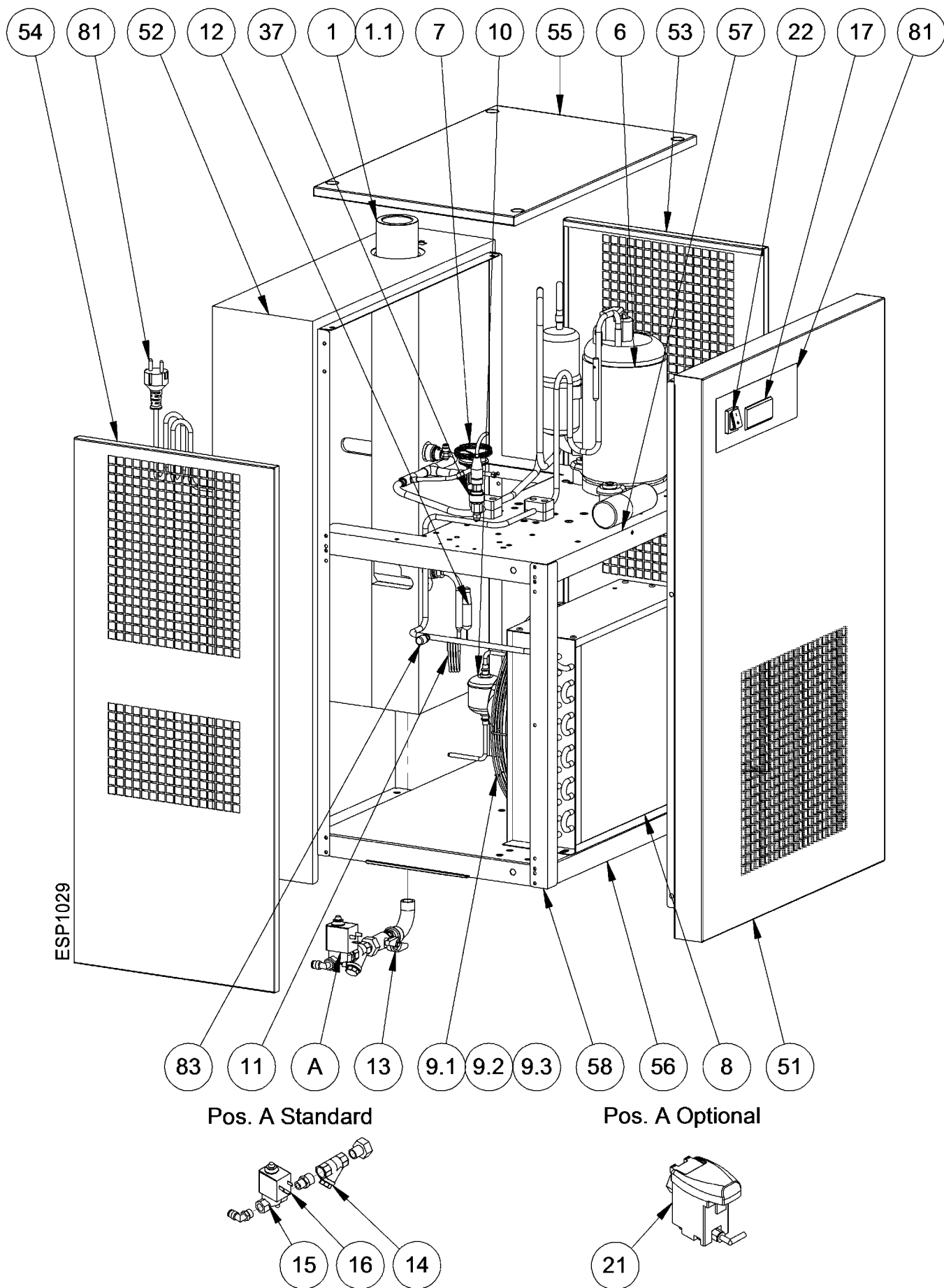

13.2.9 Exploded diagram DRYPOINT RAC 300-375 NA UL

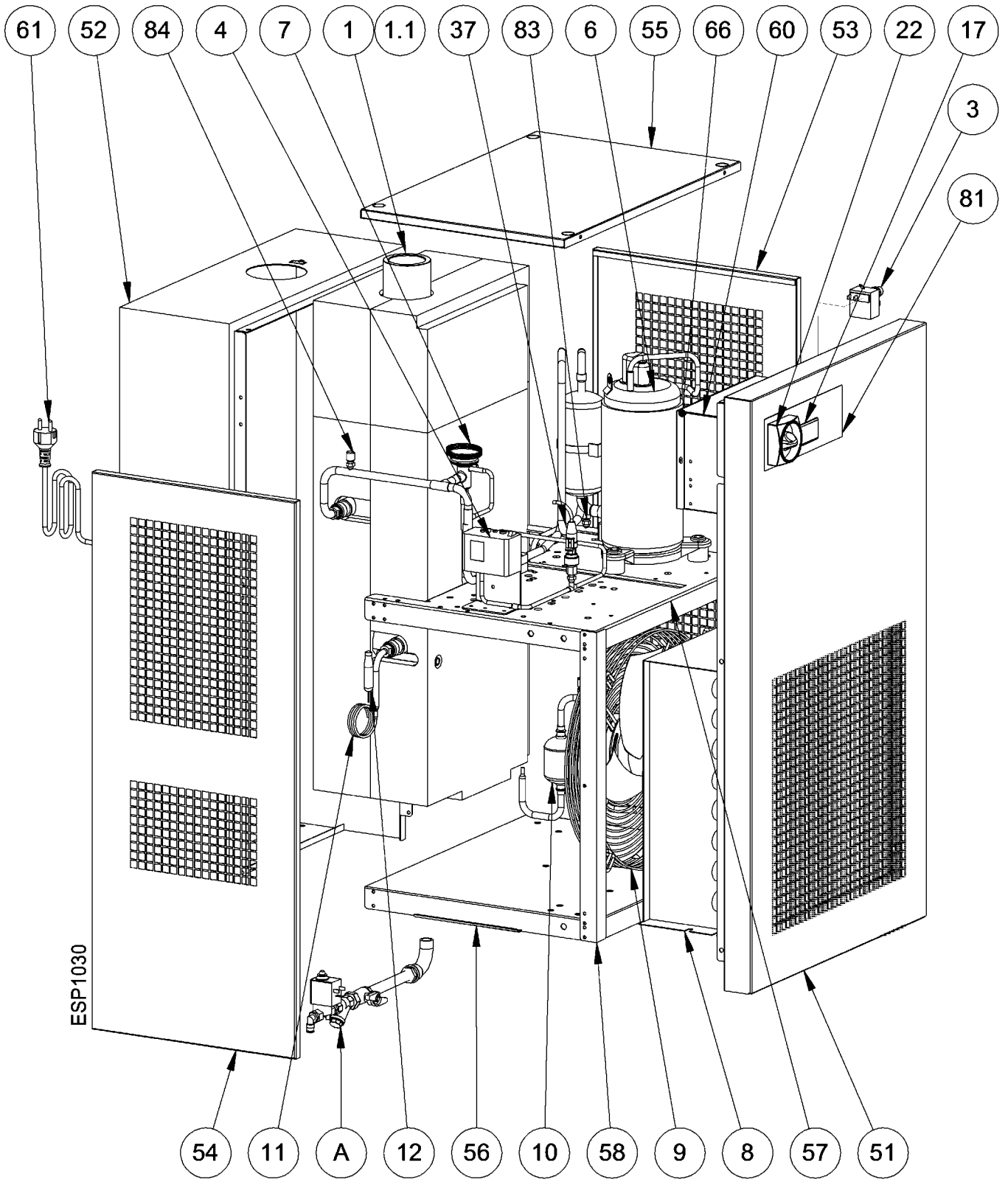

Pos. A Standard

Pos. A Optional

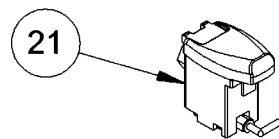
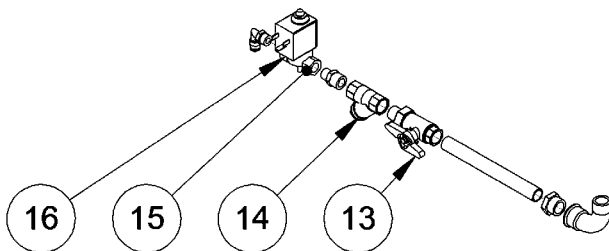

13.2.10 Exploded diagram DRYPOINT RAC 480 NA UL

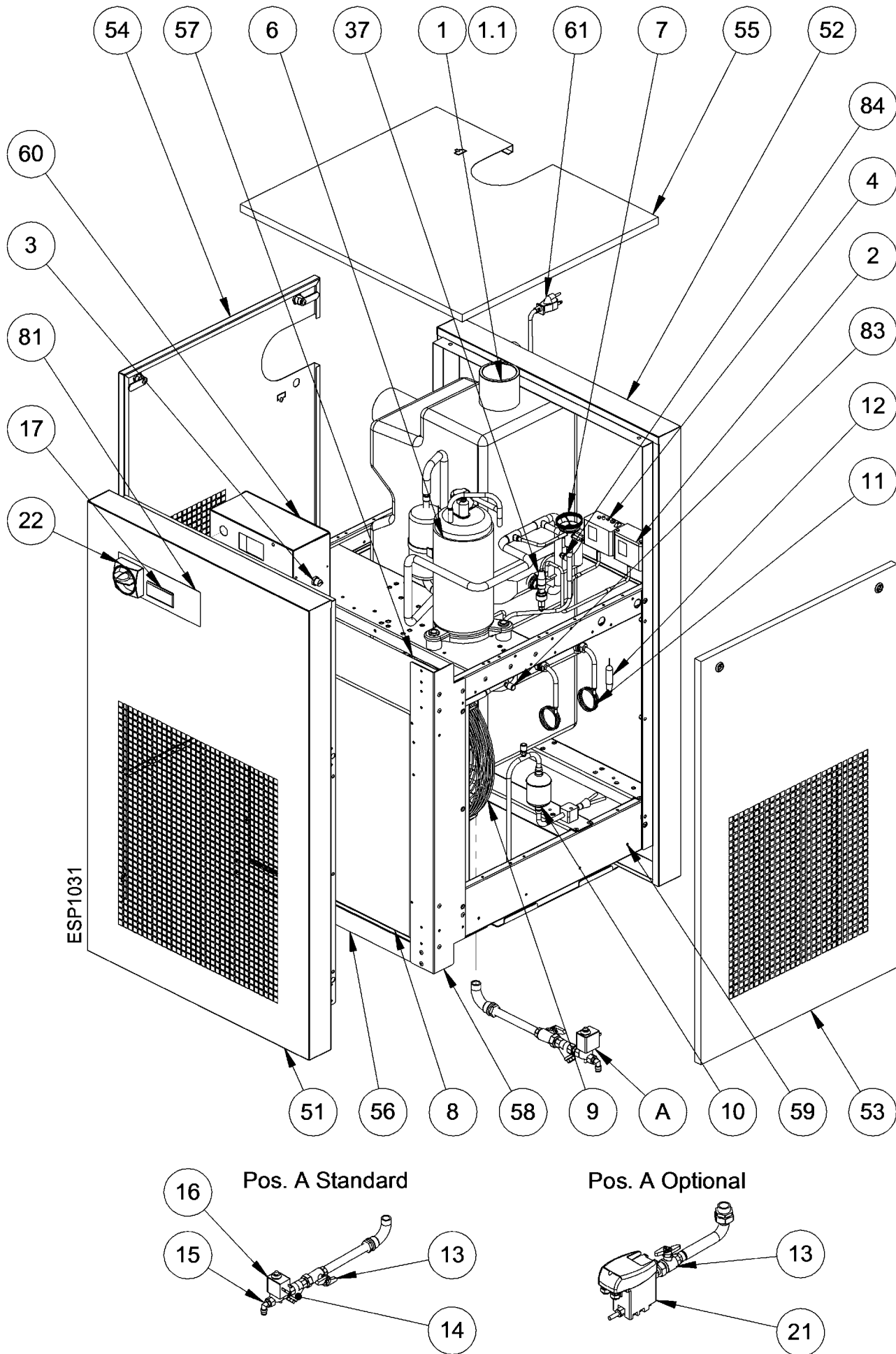

13.3.1 Electric diagrams – list of components

- MC** : Compressor
 - KT** : Compressor thermal protection
 - KR** : Compressor starting relay (if installed)
 - CS** : Compressor starting capacitor (if installed)
 - CR** : Compressor operating capacitor (if installed)
- MV** : Condenser fan
 - CV** : Fan starting capacitor (if installed)
- DMC35** : DMC35 electronic instrument – air dryer control
 - BT1** : T1 Temperature probe – dew point
 - BT2** : T2 Temperature probe – fan control
- HPS** : Pressure switch – compressor discharge side (HIGH PRESSURE)
- LPS** : Pressure switch – compressor suction side (LOW PRESSURE)
- BP2** : Pressure transducer
- TS** : Safety temperature switch
- ELD** : BEKOMAT drain
- S1** : ON/OFF switch
- TR** : Autotransformer
- BOX** : Electrical connection

- NT1** : Only air-cooled
- NT2** : Check the transformer connections with regard to the supply voltage
- NT3** : Jump, if not installed
- NT4** : Provided and cabled by the customer
- NT5** : Internal control
- NT6** : Time-controlled drain outlet (not used)
- NT7** : Only water-cooled

- KC1** : TS Power contactor

- BN** = BROWN **OR** = ORANGE
- BU** = BLUE **RD** = RED
- BK** = BLACK **WH** = WHITE
- YG** = YELLOW/GREEN **WH/BK** = WHITE/BLACK

13.3.2 Electric diagram DRYPOINT RAC 10-100 NA UL

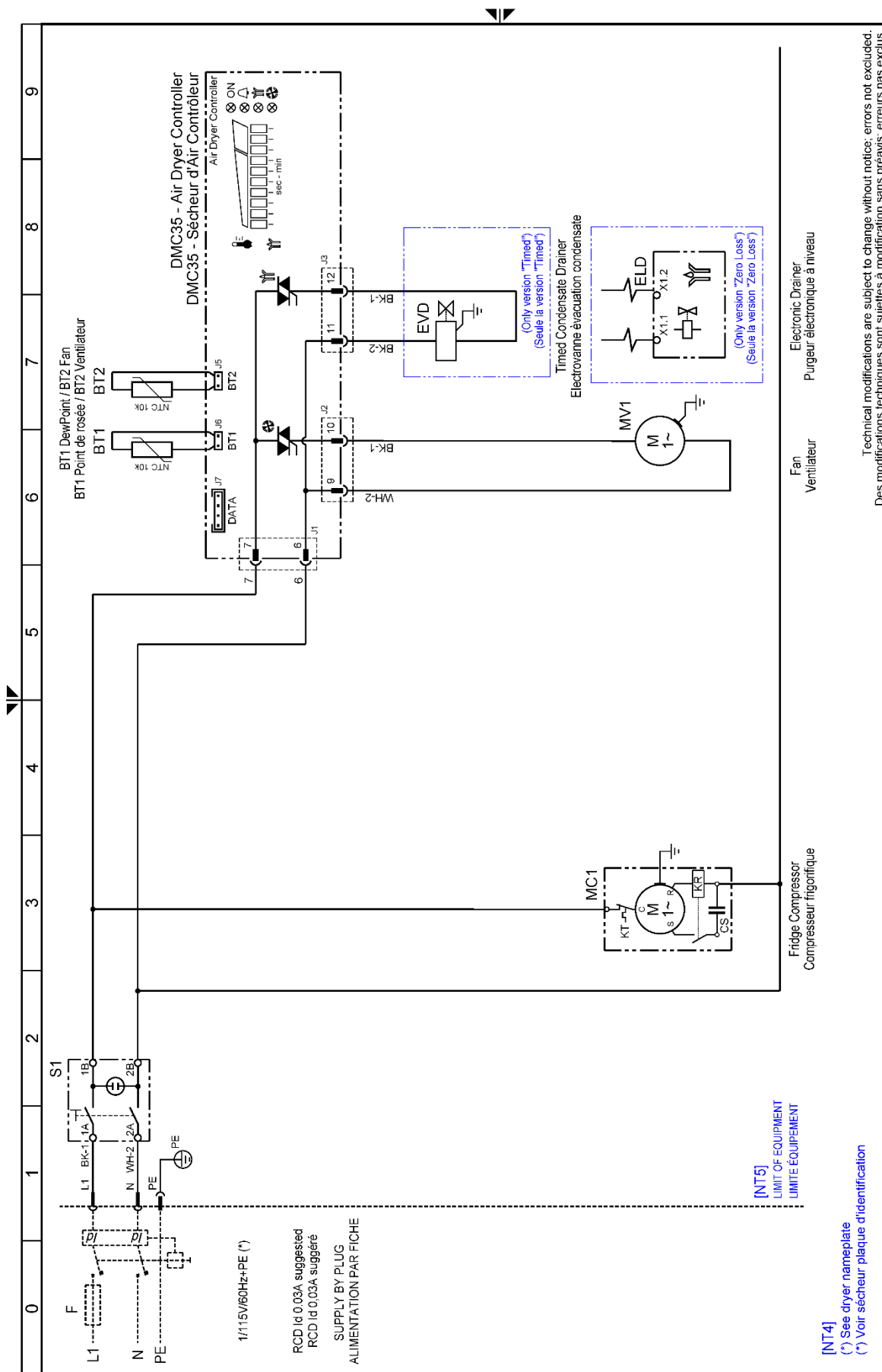

[NT4] (*) See dryer nameplate
 (*) Voir sècheur plaque d'identification

[NT5] LIMIT OF EQUIPMENT
 LIMITE EQUIPEMENT

Technical modifications are subject to change without notice; errors not excluded.
 Des modifications techniques sont sujettes à modification sans préavis; erreurs pas exclus.

Drawing no. / Numéro de dessin : WJU001_V00
 Notes / Remarques :
 Rev. / Rév. : 00
 Sheet / feuille 01 of / de 01

13.3.3 Electric diagram DRYPOINT RAC 125-175 NA UL

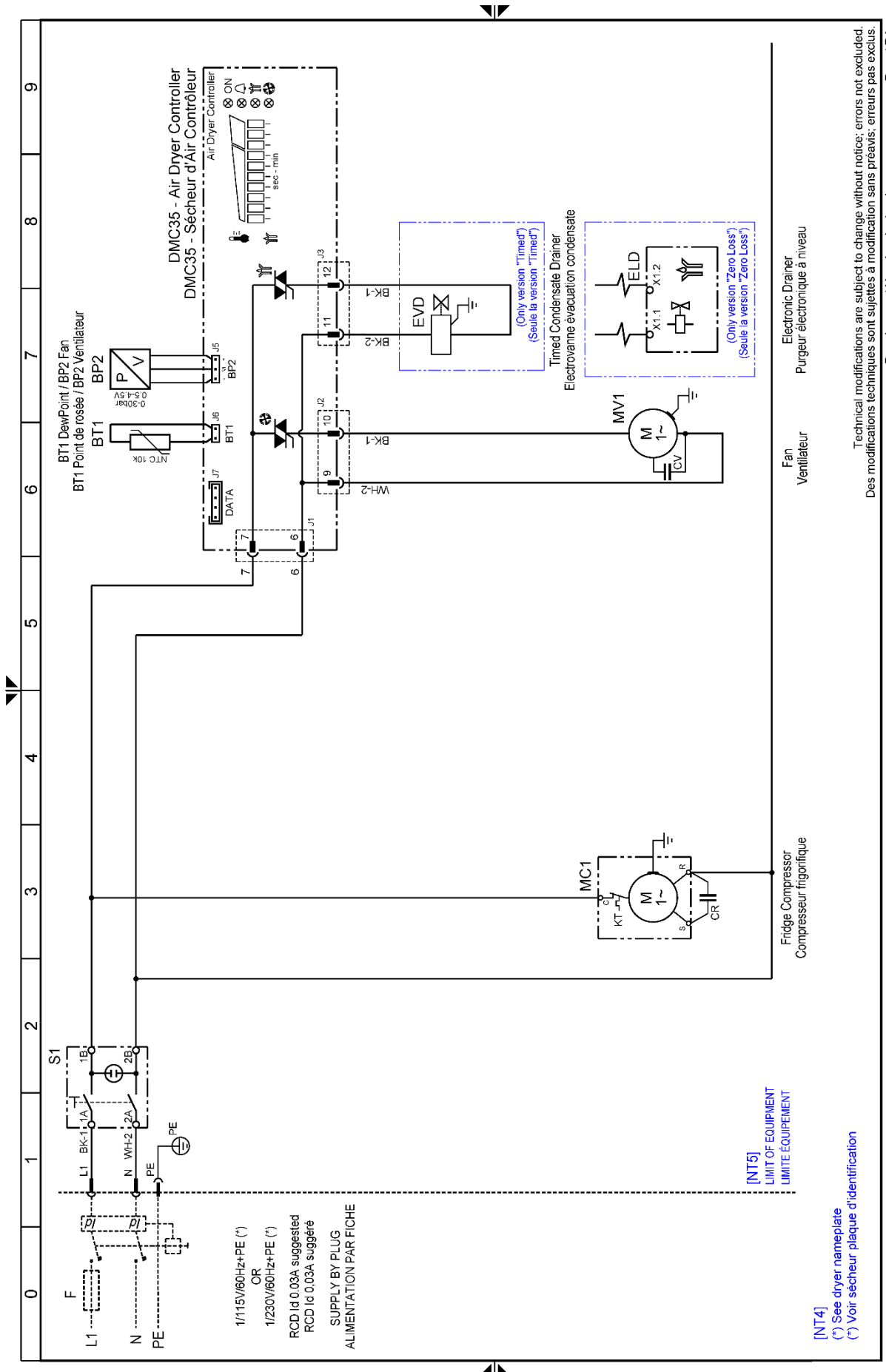

Technical modifications are subject to change without notice; errors not excluded.
Des modifications techniques sont sujettes à modification sans préavis; erreurs pas exclus.

Drawing no. / Numéro de dessin : WJ002_V00
Rev. / Rév. : 00
Notes / Remarque:

13.3.4 Electric diagram DRYPOINT RAC 220 NA UL

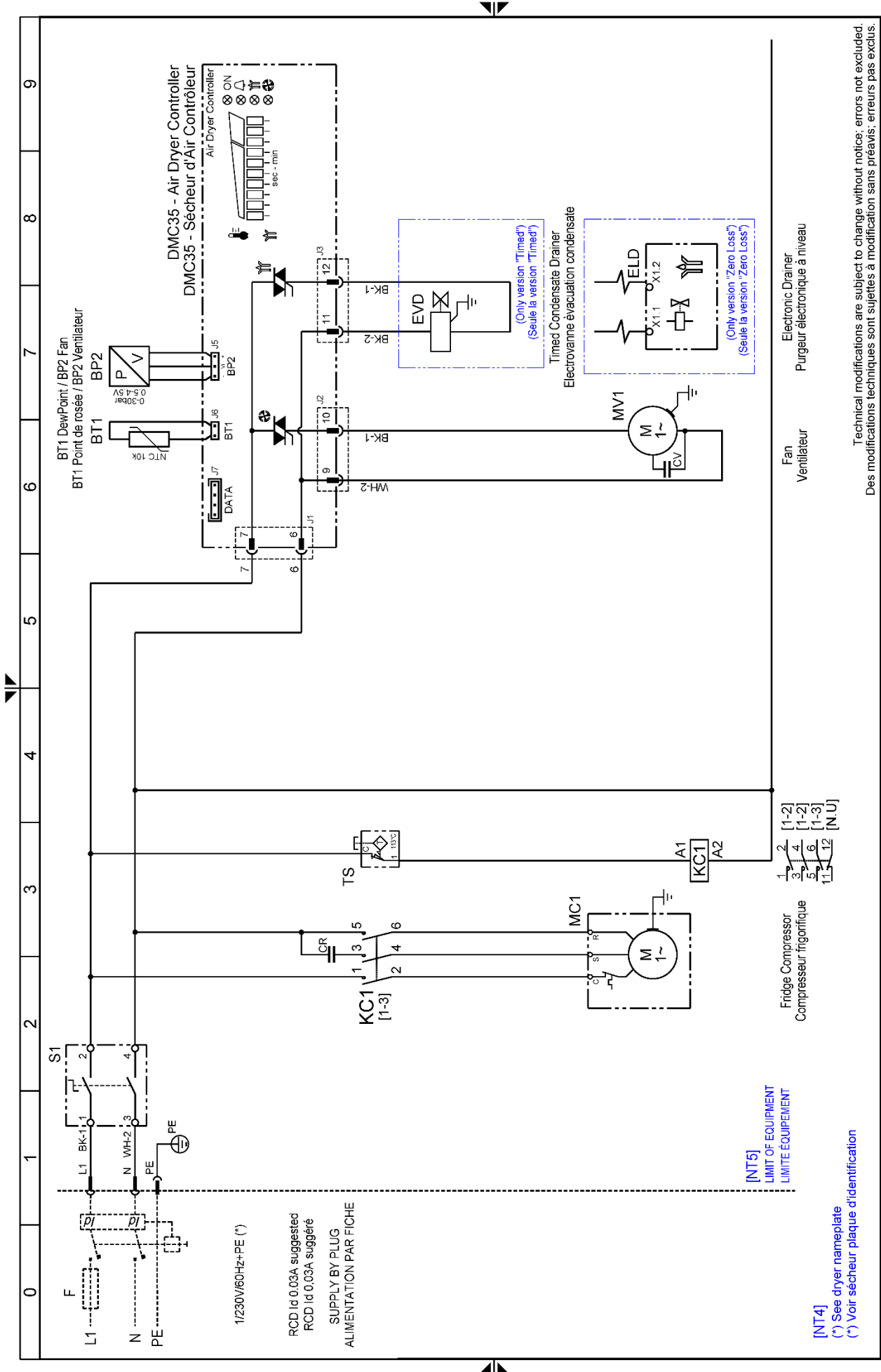

Technical modifications are subject to change without notice; errors not excluded.
 Des modifications techniques sont sujettes à modification sans préavis; erreurs pas exclus.

Drawing no. / Numéro de dessin : **WU003_V00**
 Rev. / Rev. : **00**
 Notes / Remarque: -
 Sheet / feuille **01** of / de **01**

13.3.5 Electric diagram DRYPOINT RAC 300 NA UL

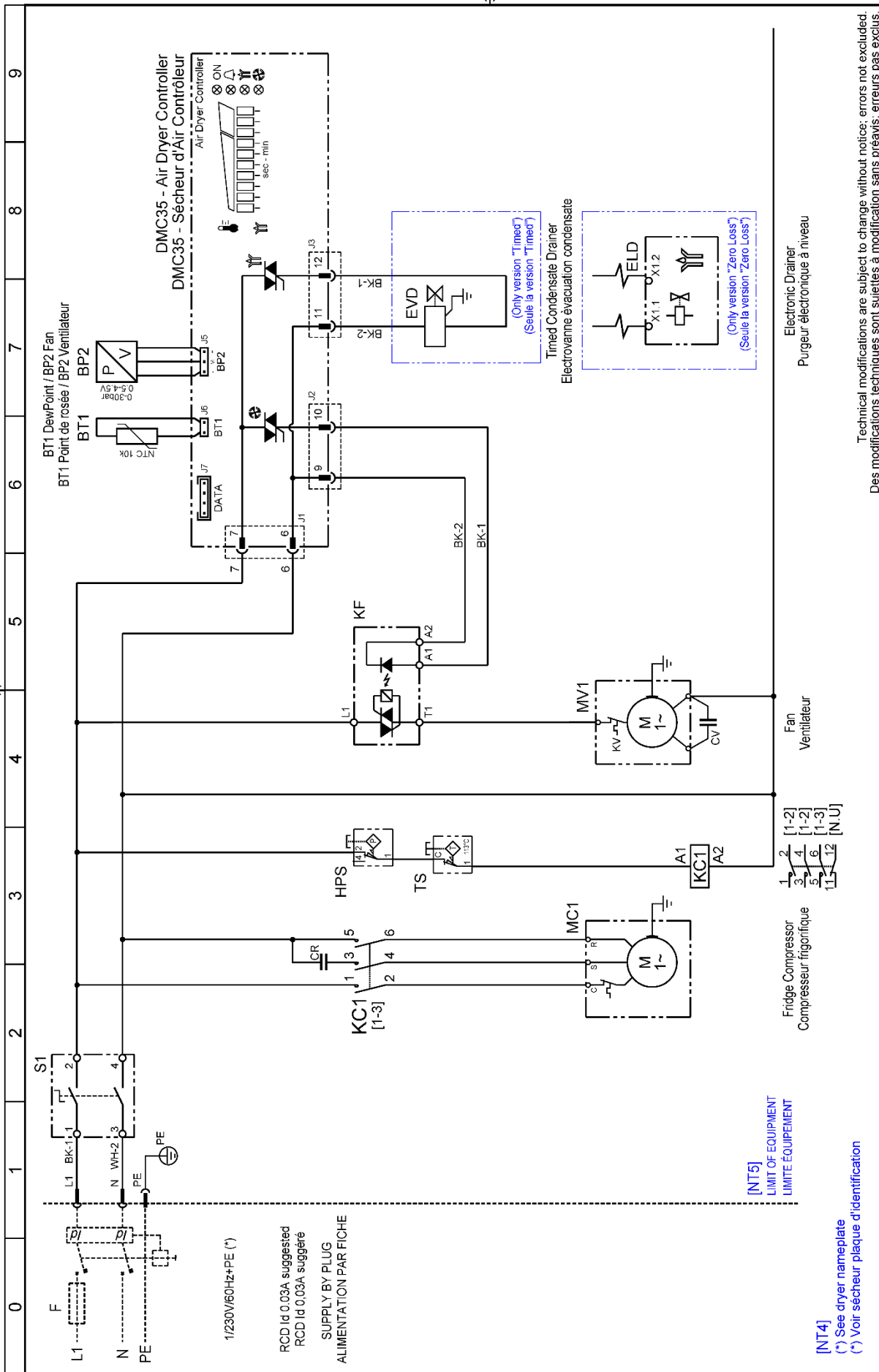

Technical modifications are subject to change without notice; errors not excluded.
 Des modifications techniques sont sujettes à modification sans préavis; erreurs pas exclus.

Drawing no. / Numéro de dessin : **WU004_V00**
 Rev. / Rév. : **00**

Notes / Remarque: -

13.3.6 Electric diagram DRYPOINT RAC 375 NA UL

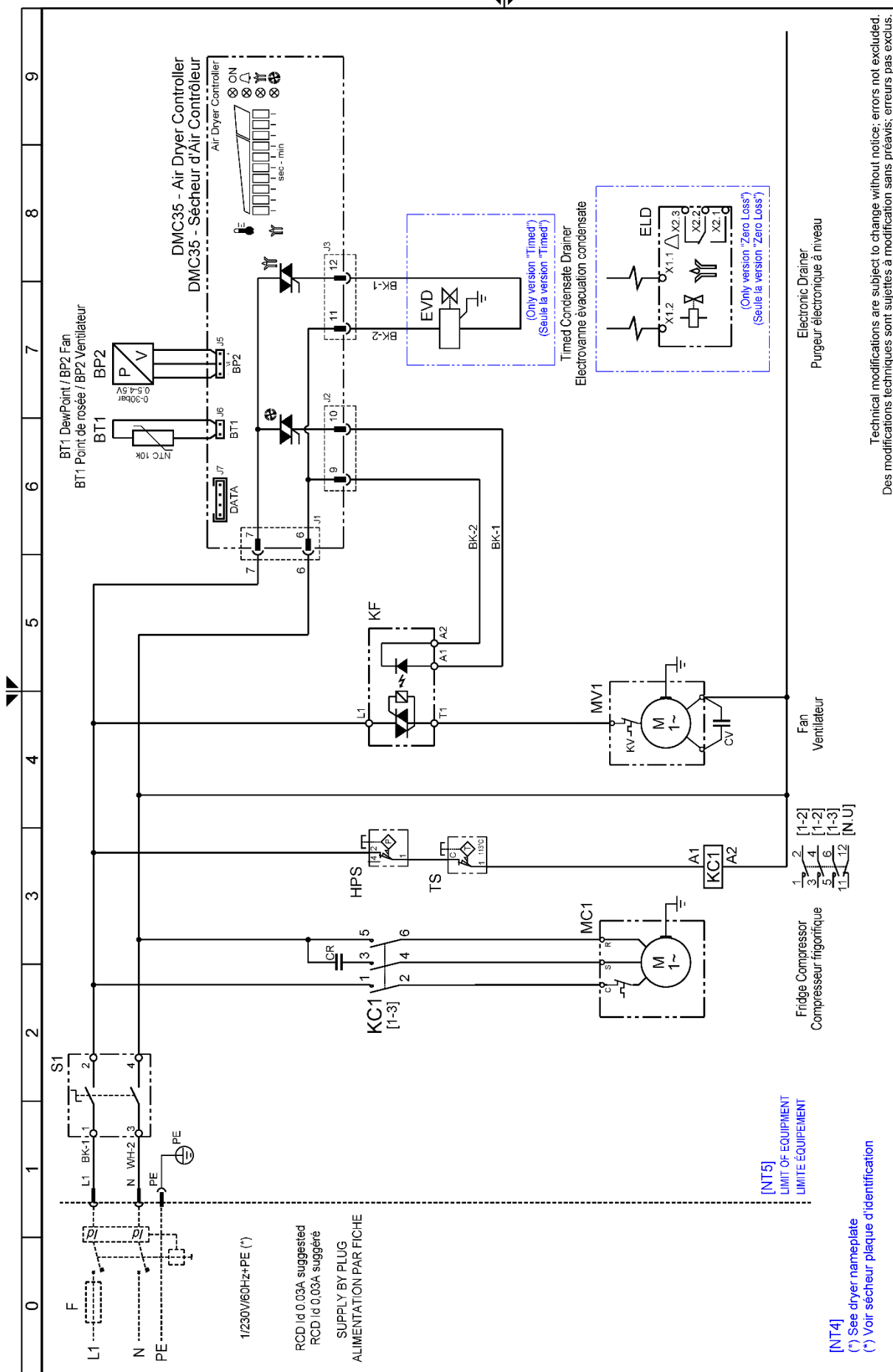

Technical modifications are subject to change without notice; errors not excluded.
Des modifications techniques sont sujettes à modification sans préavis; erreurs pas exclus.

Drawing no. / Numéro de dessin : WU005_V00

00

Notes / Remarque:

Sheet / feuille 01 of / de 01

13.3.7 Electric diagram DRYPOINT RAC 480 NA UL

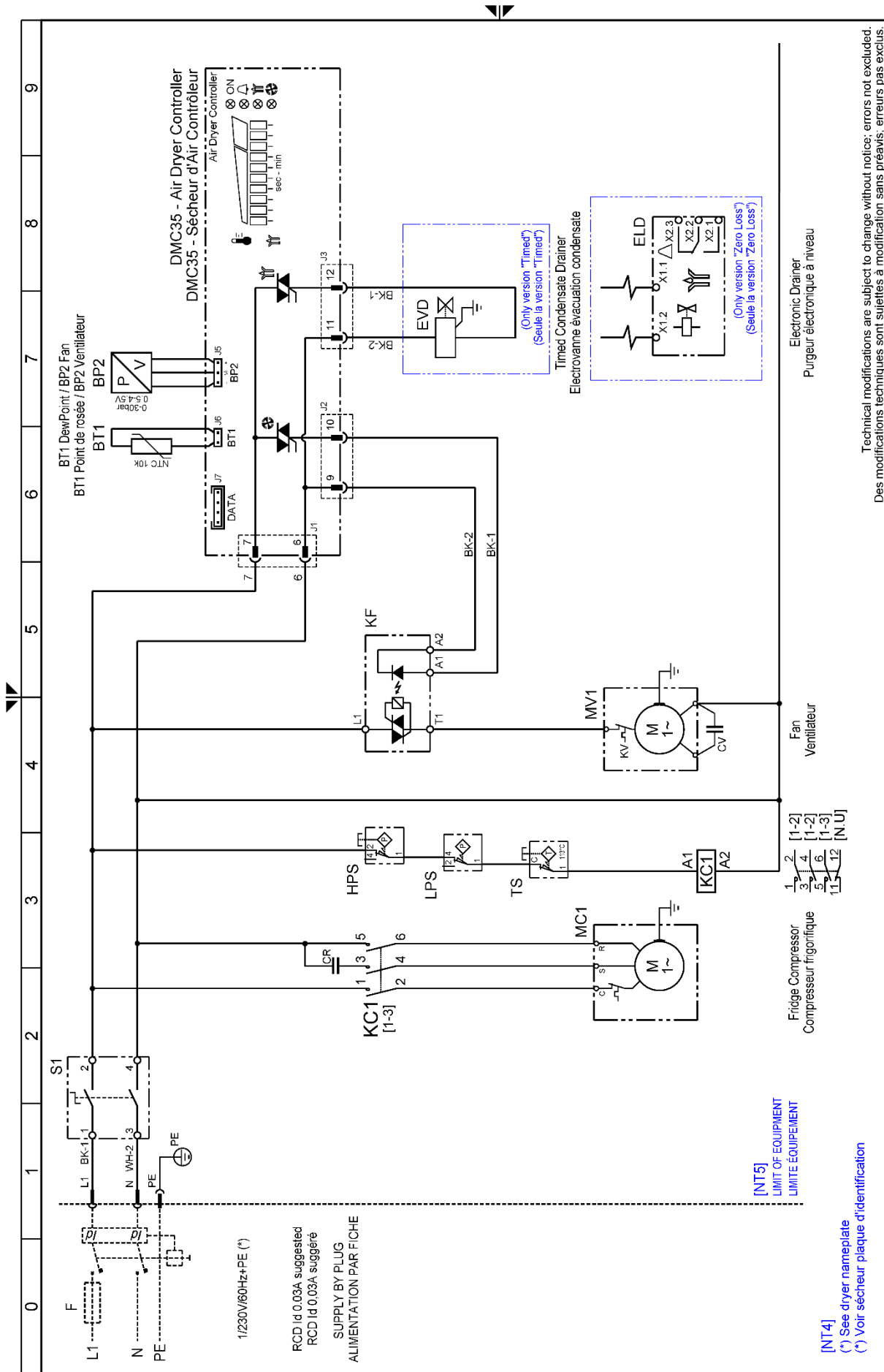

Technical modifications are subject to change without notice; errors not excluded.
Des modifications techniques sont sujettes à modification sans préavis; erreurs pas exclus.

Drawing no. / Numéro de dessin : WU006_V00
Rev. / Rév. : 00
Notes / Remarque:

| | | |
|--|---|---|
| <p>Headquarter :</p> <p>Deutschland / Germany BEKO TECHNOLOGIES GMBH Im Taubental 7 D-41468 Neuss Tel. +49 2131 988 0 info@beko-technologies.de</p> | <p>中华人民共和国 / China BEKO TECHNOLOGIES (Shanghai) Co. Ltd. Rm. 606 Tomson Commercial Building 710 Dongfang Rd. Pudong Shanghai China P.C. 200122 Tel. +86 21 508 158 85 info@beko-technologies.cn</p> | <p>France BEKO TECHNOLOGIES S.a.r.l. Zone Industrielle 1 rue des Frères Rémy F- 57200 Sarreguemines Tel. +33 387 283 800 Info@beko-technologies.fr</p> |
| <p>India BEKO COMPRESSED AIR TECHNOLOGIES Pvt. Ltd. Plot No.43/1, CIEEP, Gandhi Nagar, Balanagar, Hyderabad 500 037, INDIA Tel. +91 40 23080275 eric.purushotham@bekoindia.com</p> | <p>Italia / Italy BEKO TECHNOLOGIES S.r.l Via Peano 86/88 I - 10040 Leini (TO) Tel. +39 011 4500 576 info.it@beko-technologies.com</p> | <p>日本 / Japan BEKO TECHNOLOGIES K.K KEIHIN THINK 8 Floor 1-1 Minamiwatarida-machi Kawasaki-ku, Kawasaki-shi JP-210-0855 Tel. +81 44 328 76 01 info@beko-technologies.jp</p> |
| <p>Benelux BEKO TECHNOLOGIES B.V. Veenen 12 NL - 4703 RB Roosendaal Tel. +31 165 320 300 benelux@beko-technologies.com</p> | <p>Polska / Poland BEKO TECHNOLOGIES Sp. z o.o. ul. Chłapowskiego 47 PL-02-787 Warszawa Tel. +48 22 855 30 95 info.pl@beko-technologies.pl</p> | <p>Scandinavia www.beko-technologies.de</p> |
| <p>España / Spain BEKO Tecnológica España S.L. Torruella i Urpina 37-42, nave 6 E-08758 Cervelló Tel. +34 93 632 76 68 info.es@beko-technologies.es</p> | <p>South East Asia BEKO TECHNOLOGIES S.E.Asia (Thailand) Ltd. 75/323 Romklao Road Sansab, Minburi Bangkok 10510 - Thailand Tel. +66 2-918-2477 info.th@beko-technologies.com</p> | <p>臺灣 / Taiwan BEKO TECHNOLOGIES Co.,Ltd 16F-5, No.79, Sec. 1, Xintai 5th Rd., Xizhi Dist., New Taipei City 221, Taiwan (R.O.C.) Tel. +886 2 8698 3998 info@beko.com.tw</p> |
| <p>Česká Republika / Czech Republic BEKO TECHNOLOGIES s.r.o. Mlýnská 1392 CZ - 562 01 Usti nad Orlici Tel. +420 465 52 12 51 info.cz@beko-technologies.cz</p> | <p>United Kingdom BEKO TECHNOLOGIES LTD. 2 West Court Buntsford Park Road Bromsgrove GB-Worcestershire B60 3DX Tel. +44 1527 575 778 info@beko-technologies.co.uk</p> | <p>USA BEKO TECHNOLOGIES CORP. 900 Great SW Parkway US - Atlanta, GA 30336 Tel. +1 404 924-6900 beko@bekousa.com</p> |

Original operating instructions in English.
Subject to technical changes / errors excepted.