



RAD-0025-RAD-1250 and RHT-0010-RHT-0120 Series



Manual



Scan to access www.AltecAIR.com

Altec AIR, LLC reserves the right to improve models and change specifications without notice.

100514920AA

Copyright © 2025 by Altec AIR, LLC

All rights reserved. No part of this publication may be used or reproduced by any means, or stored in a database or retrieval system, without prior written permission of the publisher. Making copies of any part of this publication for any purpose other than personal use is a violation of United States copyright laws.

Air Dryer Registration

Take a moment to register your Altec AIR air dryer. Registering is necessary to activate the limited warranty. Once registered, you are eligible to receive free technical support, as well as updates concerning your Altec AIR products.

Register online at www.AltecAIR.com/product-support/registration/ or by phone at 1-800-521-5351 (option 2).

Product information can be found on the data label.

Product Information

Model number _____ Serial number _____

Date purchased _____ Date installed _____

Distributor company name (if applicable) _____

Customer company name _____

Installation Location Information

Location name (if applicable) _____

Street address _____

City _____ State _____ ZIP code _____

Contact Information

Contact name _____

Phone number () - ex . _____

Email _____



Scan to access www.AltecAIR.com

DATA LABEL

Model	
Serial No.	
Date of MFG	
Voltage	
RLA	
LRA	
Min Circuit Ampacity	
Max Fuse Size	
Max Inlet Air Temp - F	
Min/Max Ambient Temp - F	
Max Pressure (PSIG)	
Ref. System Design - PSI	
Suction/Discharge - PSI	
Refrigerant Type	
Refrigerant Charge	
 REFRIGERATED AIR DRYER	
www.AltecAIR.com 800-521-5351 Made in the USA	
DISCONNECT POWER SUPPLY BEFORE SERVICING	

Preface

The air dryer is the result of Altec AIR's advanced technology and quality awareness in design, engineering, and manufacturing. All information, illustrations, and specifications contained within the manual are based on the latest product information available at the time of publication. It is essential that all personnel involved in the use and/or care of the air dryer read and understand the manual. Keep the manual with the air dryer.

Given reasonable care and operation, according to the guidelines set forth in the manuals provided, this air dryer will provide many years of excellent service before requiring major maintenance.

Impacts to and excessive forces on the refrigeration equipment, through accidents and the like, may result in structural damage not obvious during a visual inspection. If the refrigeration equipment is subjected to such impacts or forces, a qualified person may need to perform additional testing such as pressure and leak tests, as applicable. If structural damage is suspected or found, contact Altec AIR for additional instructions.

NOTICE

Continued use of an air dryer with damage could lead to component failure.

Do not alter or modify the air dryer in any way that might affect the structural integrity or operational characteristics without the specific written approval of Altec AIR or an equivalent entity. Unauthorized alterations or modifications will void the warranty. Of greater concern, is the possibility that unauthorized modification could adversely affect the safe operation of this air dryer, resulting in personal injury and/or property damage.

California Proposition 65 Warning



The air dryer may contain or emit chemicals known to the State of California to cause cancer and birth defects or other reproductive harm.

Table of Contents

Section 1 — Introduction	
About This Manual.....	1
Additional Resources.....	1
Section 2 — Air Dryer Specifications	
Purpose of the Air Dryer.....	3
General Specifications	3
Refrigerated Non-Cycling Series Air Dryer Models.....	3
Component Identification	7
Section 3 — Safety	
Safety Instructions	11
Air Dryer Electrical Information	11
Disclaimer of Liability	11
Section 4 — Installation	
Safety and Warning Information.....	13
Before You Begin	13
Installation Configurations.....	14
Air Receiver Tank Setup	15
Installation Procedure	15
Section 5 — Operation and Maintenance	
Air Dryer Access	17
Refrigerant Manifold.....	17
Functional Flow Diagrams	18
Drain Valve.....	20
Hot Gas Bypass Valve	20
Thermostatic Expansion Valve.....	20
Condenser and Fan	21
Compressor	21
Accumulator	22
Cross-Flow Heat Exchanger.....	22
Maintenance	22
Section 6 — Troubleshooting	
Before Calling Altec AIR.....	25
Troubleshooting Procedure.....	25
Contacting Altec AIR Technical Support.....	25
Section 7 — Parts	
Introduction	27
Single Phase Air Dryers	28
Three Phase Air Dryers.....	30
Section 8 — Options	
Digital Scroll Compressor	33
Programmable Timer	33
Programming the P Series Timer	33
Frequently Asked Questions.....	36
Zero-Loss Drain	37
Operating the Drain	37
Control Panel and Alarms.....	37
Drain Maintenance	38
Troubleshooting the Drain	41

Appendix

Accessories

Wiring Diagrams

Troubleshooting Chart

Section 1 — Introduction

About This Manual...

This manual provides information specific to Altec AIR Refrigerated Non-Cycling Series air dryers. The models covered include RAD-0025 through RAD-1250 and RHT-0010 through RHT-0120. This manual is written to provide an understanding of the air dryer including safety, specifications, installation, registration, operation, testing, maintenance, replacement parts, service, and troubleshooting. Observation and compliance with this manual will ensure the maximum life and efficiency of the air dryer.

Read this manual thoroughly prior to installing, operating, or servicing the air dryer to become familiar with the recommended procedures. This will minimize the possibility of personal injury or damage to the air dryer due to improper operation or handling.

Charts and figures are provided to support the text. Because options vary from one model to another, some figures may only be a representation of what is actually on the air dryer.

Contact the following organizations for additional information.

- American National Standards Institute (ANSI)
- Electrical Testing Laboratories (ETL)
- International Society of Automation (ISA)
- National Electrical Manufacturers Association (NEMA)
- Occupational Safety and Health Administration (OSHA)
- Underwriters Laboratories (UL)

The Appendix contains reference items to assist in air dryer operation and maintenance.

This symbol is used throughout this manual to indicate danger, warning, and caution instructions. These instructions must be followed to reduce the likelihood of personal injury and/or property damage.



The terms danger, warning, caution, and notice represent varying degrees of personal injury and/or property damage that could result if the preventive instructions are not followed. The following paragraphs from ANSI publications explain each term.

Danger

Indicates a hazardous situation which, if not avoided, will result in death or serious injury. This signal word is to be limited to the most extreme situations.

Warning

Indicates a hazardous situation which, if not avoided, could result in death or serious injury.

Caution

Indicates a hazardous situation which, if not avoided, could result in minor or moderate injury.

Notice

Indicates information considered important, but not hazard related.

Additional Resources

A digital version of this manual is provided online through Altec AIR. To access Altec AIR, scan the QR code on the cover of this manual or go to www.AltecAIR.com.

Additional print copies of this manual may be ordered through your Altec AIR representative. Supply the model and serial number located on the data label and the manual part number from the front cover to assure that the proper manual will be supplied.

Section 2 — Air Dryer Specifications

Purpose of the Air Dryer

This refrigerated air dryer has been specifically designed, manufactured, and tested for the purpose of reducing the humidity in compressed air. Any other use is considered improper. Altec AIR is not responsible for any problem due to improper use. Outlet air from the air dryer is not intended for use in breathing, food, or other sterile applications.

Proper use requires the following to adhere to the installation instructions.

- Main power source voltage and frequency
- Flow rate, pressure, and temperature of the inlet air
- Inlet air quality (dirty air with solid particulates not acceptable)
- Ambient temperature

General Specifications

The refrigerated non-cycling air dryer series is designed to meet the demand of the compressed air system. RAD Series models range from 25 to 1,250 standard cubic feet per minute (SCFM). RHT models range from 10 to 120 SCFM.

- Consistent and reliable dry air at 45 degrees Fahrenheit (7 degrees Celsius) outlet dew point for RAD Series, or 50 degrees Fahrenheit (10 degrees Celsius) outlet dew point for RHT Series air dryers
- Compact, all-aluminum, heat exchanger modules with low pressure drops
- Programmable, automatic, electronic drains
- Easy access cabinet design for ease of maintenance and serviceability
- Suction pressure gauges provide simple and reliable monitoring of the air dryer's refrigeration system
- Top mounted inlet and outlet connections allow for easy installation of the air dryer, filters, and bypass valves
- Outlet air pressure drop of 2 psi (0.14 bar) or less at rated conditions

Refrigerated Non-Cycling Series Air Dryer Models

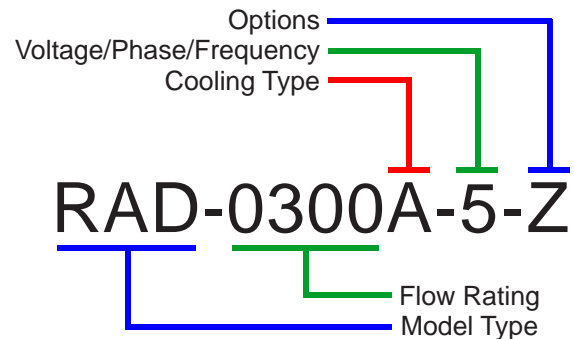

Model Type

- *RAD* – 100 degrees Fahrenheit (38 degrees Celsius) saturated, 100 pounds per square inch gauge (PSIG) inlet air, 45 degrees Fahrenheit (7 degrees Celsius) outlet dew point
- *RHT* – 180 degrees Fahrenheit (82 degrees Celsius), 160 degrees Fahrenheit (71 degrees Celsius) dew point, 150 PSIG inlet air, 50 degrees Fahrenheit (10 degrees Celsius) outlet dew point

Flow Rating

- RAD Series flow rates are 25 - 1,250 SCFM
- RHT Series flow rates are 10 - 120 SCFM

Cooling Type

- A – Air cooled
- W – Water cooled*

Nominal Voltage/Phase/Frequency

- 1 – 115V/1Ph/60 Hz
- 2 – 230V/1Ph/60 Hz
- 3 – 230V/3Ph/60 Hz
- 4 – 460V/3Ph/60 Hz
- 5 – 575V/3Ph/60 Hz

Options

- D – Digital scroll compressor*
- P – Programmable timer
- Z – Zero-loss drain*

* Options may not be available at the time of print. Contact Altec AIR for more information.

The conditions and electrical information for the air dryer vary by model (refer to Figures 2.1 and 2.2). Air dryers equipped with a digital scroll compressor (option D) have specific electrical information that differs from a standard model (refer to Figure 2.3).

Item	RAD-0025 through RAD-0200	RAD-0250/0300	RAD-0400 through RAD-1250	RHT-0010 through RHT-0080	RHT-0100 through RHT-0120
Max mum inlet air temperature (F)	140	140	140	200	200
Max mum inlet air pressure (PSIG)	232	232	232	232	232
Minimum ambient air temperature (F)	45	45	45	45	45
Max mum ambient air temperature (F)	120	120	120	120	120
Minimum refrigerant pressure (PSIG)	150	181	181	150	181
Max mum refrigerant pressure (PSIG)	300	450	450	300	450
Suction pressure (PSIG)	30	80	67	30	80
Discharge pressure (PSIG)	115	225	225	115	225
Drain port NPT	1/4"	1/4"	1/4"	1/4"	1/4"

Figure 2.1 — Air Dryer Conditions

Model	Voltage	RLA ¹	LRA ²	MCA ³	MOP ⁴	HP	Charge (oz)	Cord/Plug Type
RAD-0025-1/RHT-0010-1	115V-1Ph-60 Hz	3.7	29	6.2	15	1/5	9	NEMA 5-15P
RAD-0040-1/RHT-0015-1	115V-1Ph-60 Hz	3.7	29	6.2	15	1/5	9	NEMA 5-15P
RAD-0055-1/RHT-0020-1	115V-1Ph-60 Hz	4.9	28	8.4	15	1/4	9	NEMA 5-15P
RAD-0075-1/RHT-0030-1	115V-1Ph-60 Hz	5.8	32	9.8	15	1/3	9	NEMA 5-15P
RAD-0075-2/RHT-0030-2	230V-1Ph-60 Hz	3.0	16	5.2	15	1/3	9	Cord only
RAD-0100-1/RHT-0040-1	115V-1Ph-60 Hz	9.5	48	15.4	25	1/2	12	NEMA 5-15P
RAD-0100-2/RHT-0040-2	230V-1Ph-60 Hz	4.8	23	7.9	15	1/2	12	Cord only
RAD-0150-1/RHT-0060-1	115V-1Ph-60 Hz	13.6	56	21.4	35	3/4	15	NEMA 5-20P
RAD-0150-2/RHT-0060-2	230V-1Ph-60 Hz	7.3	38	12.0	20	3/4	15	Cord only
RAD-0200-1/RHT-0080-1	115V-1Ph-60 Hz	13.6	78	24.3	40	1 1/4	24	NEMA 5-20P
RAD-0200-2/RHT-0080-2	230V-1Ph-60 Hz	11.8	37	19.4	30	1	24	Cord only
RAD-0250-3/RHT-0100-3	230V-3Ph-60 Hz	6.0	38	5.8	15	1 1/4	37	No cord or plug
RAD-0250-4/RHT-0100-4	460V-3Ph-60 Hz	3.9	20	2.9	15	1 1/4	37	No cord or plug
RAD-0250-5/RHT-0100-5 ⁵	575V-3Ph-60 Hz	3.1	16	2.3	15	1 1/4	37	No cord or plug
RAD-0300-3/RHT-0120-3	230V-3Ph-60 Hz	6.0	38	5.8	15	1 1/4	37	No cord or plug
RAD-0300-4/RHT-0120-4	460V-3Ph-60 Hz	3.9	20	2.9	15	1 1/4	37	No cord or plug
RAD-0300-5/RHT-0120-5 ⁵	575V-3Ph-60 Hz	3.1	16	2.3	15	1 1/4	37	No cord or plug
RAD-0400-3	230V-3Ph-60 Hz	10.3	55	10.0	25	3 1/2	80	No cord or plug
RAD-0400-4	460V-3Ph-60 Hz	6.0	27	5.0	15	3 1/2	80	No cord or plug
RAD-0400-5 ⁵	575V-3Ph-60 Hz	4.8	22	4.0	15	3 1/2	80	No cord or plug
RAD-0500-3	230V-3Ph-60 Hz	10.3	55	10.0	25	3 1/2	88	No cord or plug
RAD-0500-4	460V-3Ph-60 Hz	6.0	27	5.0	15	3 1/2	88	No cord or plug
RAD-0500-5 ⁵	575V-3Ph-60 Hz	4.8	22	4.0	15	3 1/2	88	No cord or plug
RAD-0600-3	230V-3Ph-60 Hz	11.4	55	11.6	30	3 1/2	96	No cord or plug
RAD-0600-4	460V-3Ph-60 Hz	6.0	31	5.8	15	3 1/2	96	No cord or plug
RAD-0600-5 ⁵	575V-3Ph-60 Hz	4.8	25	4.7	15	3 1/2	96	No cord or plug
RAD-0750-4	460V-3Ph-60 Hz	8.0	39	6.1	20	4 1/2	144	No cord or plug
RAD-0750-5 ⁵	575V-3Ph-60 Hz	6.4	31	4.9	15	4 1/2	144	No cord or plug
RAD-1000-4	460V-3Ph-60 Hz	10.1	50	9.2	25	6	144	No cord or plug
RAD-1000-5 ⁵	575V-3Ph-60 Hz	8.1	40	7.3	20	6	144	No cord or plug
RAD-1250-4	460V-3Ph-60 Hz	11.5	63	11.7	30	7	160	No cord or plug
RAD-1250-5 ⁵	575V-3Ph-60 Hz	9.2	50	9.4	25	7	160	No cord or plug

¹ Rated load amps – the maximum current the air dryer should draw from the supply under any operating conditions.

² Locked rotor amperage – the highest current the air dryer draws from the supply when power is first applied.

³ Minimum circuit amps – the highest steady-state electrical current.

⁴ Maximum over-current protection – the maximum size of over-current protection device such as circuit breakers or fuses.

⁵ Air dryer -5 models may utilize an internal power transformer to accommodate 575V-3Ph-60 Hz supply voltage. The air dryer's data label reflects loads and ratings for the incoming electrical supply.

Figure 2.2 — RAD and RHT Electrical Information

Model	Voltage	RLA ¹	LRA ²	MCA ³	MOP ⁴	HP	Charge (oz)	Cord/Plug Type
RAD-0400-3-D	230V-3Ph-60 Hz	14.0	77	13.4	40	4 ^{1/2}	80	No cord or plug
RAD-0400-4-D	460V-3Ph-60 Hz	8.1	39	7.1	20	4 ^{1/2}	80	No cord or plug
RAD-0400-5-D ⁵	575V-3Ph-60 Hz	6.5	31	5.6	15	4 ^{1/2}	80	No cord or plug
RAD-0500-3-D	230V-3Ph-60 Hz	14.0	77	14.1	40	4 ^{1/2}	88	No cord or plug
RAD-0500-4-D	460V-3Ph-60 Hz	8.1	39	7.1	20	4 ^{1/2}	88	No cord or plug
RAD-0500-5-D ⁵	575V-3Ph-60 Hz	6.5	31	5.6	15	4 ^{1/2}	88	No cord or plug
RAD-0600-3-D	230V-3Ph-60 Hz	14.0	77	14.1	40	4 ^{1/2}	96	No cord or plug
RAD-0600-4-D	460V-3Ph-60 Hz	8.1	39	7.1	20	4 ^{1/2}	96	No cord or plug
RAD-0600-5-D ⁵	575V-3Ph-60 Hz	6.5	31	5.6	15	4 ^{1/2}	96	No cord or plug
RAD-0750-4-D	460V-3Ph-60 Hz	9.0	39	7.1	20	4 ^{1/2}	144	No cord or plug
RAD-0750-5-D ⁵	575V-3Ph-60 Hz	7.2	31	5.6	15	4 ^{1/2}	144	No cord or plug
RAD-1000-4-D	460V-3Ph-60 Hz	9.3	48	9.5	25	6	144	No cord or plug
RAD-1000-5-D ⁵	575V-3Ph-60 Hz	7.4	38	7.6	20	6	144	No cord or plug
RAD-1250-4-D	460V-3Ph-60 Hz	11.9	75	13.6	30	8	160	No cord or plug
RAD-1250-5-D ⁵	575V-3Ph-60 Hz	9.5	60	10.9	25	8	160	No cord or plug

¹ Rated load amps – the maximum current the air dryer should draw from the supply under any operating conditions.

² Locked rotor amperage – the highest current the air dryer draws from the supply when power is first applied.

³ Minimum circuit amps – the highest steady-state electrical current.

⁴ Maximum over-current protection – the maximum size of over-current protection device such as circuit breakers or fuses.

⁵ Air dryer -5 models may utilize an internal power transformer to accommodate 575V-3Ph-60 Hz supply voltage. The air dryer's data label reflects loads and ratings for the incoming electrical supply.

Figure 2.3 — Digital Scroll Compressor Electrical Information

Component Identification

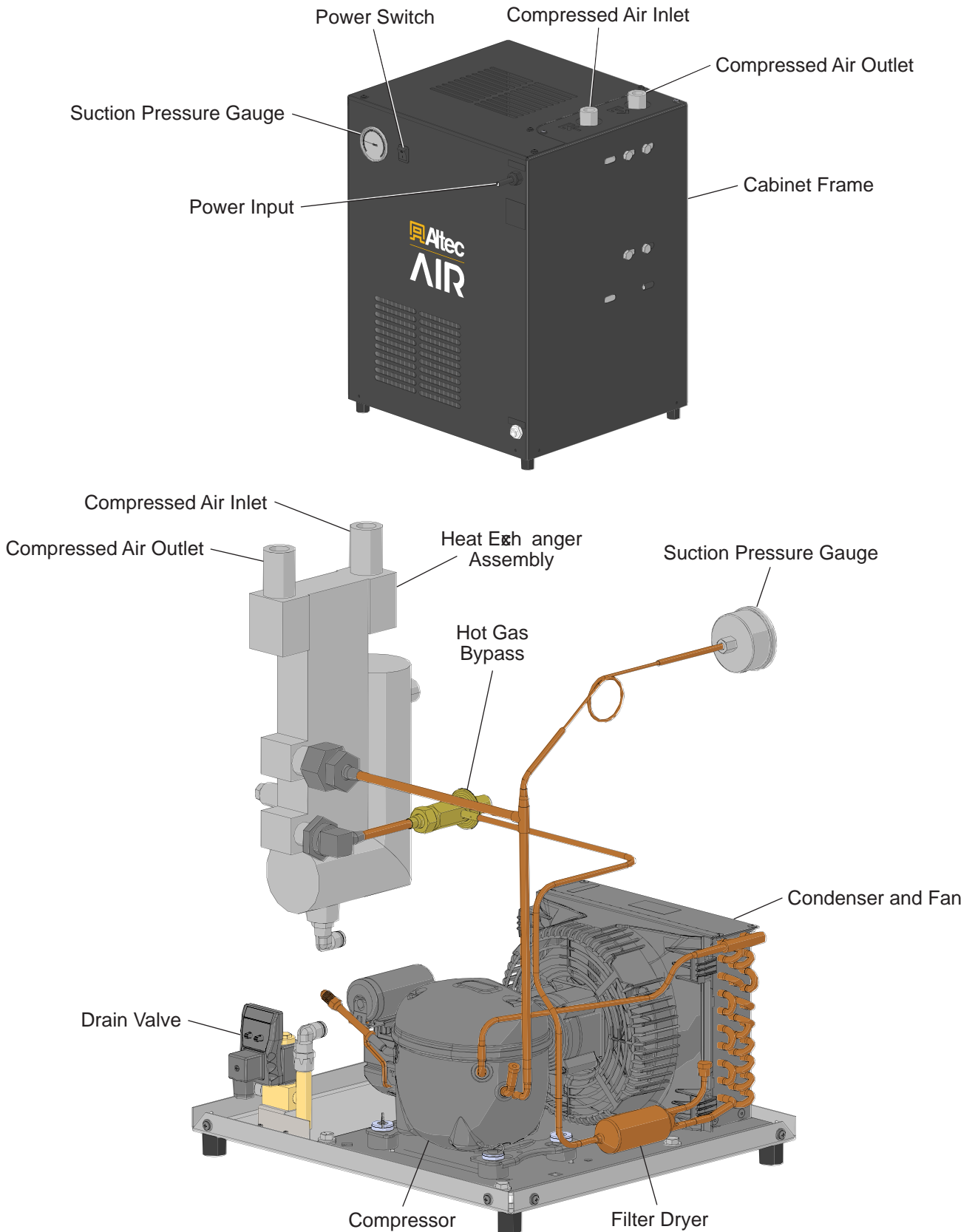

RAD-0025, RAD-0040, RAD-0055, and RAD-0075

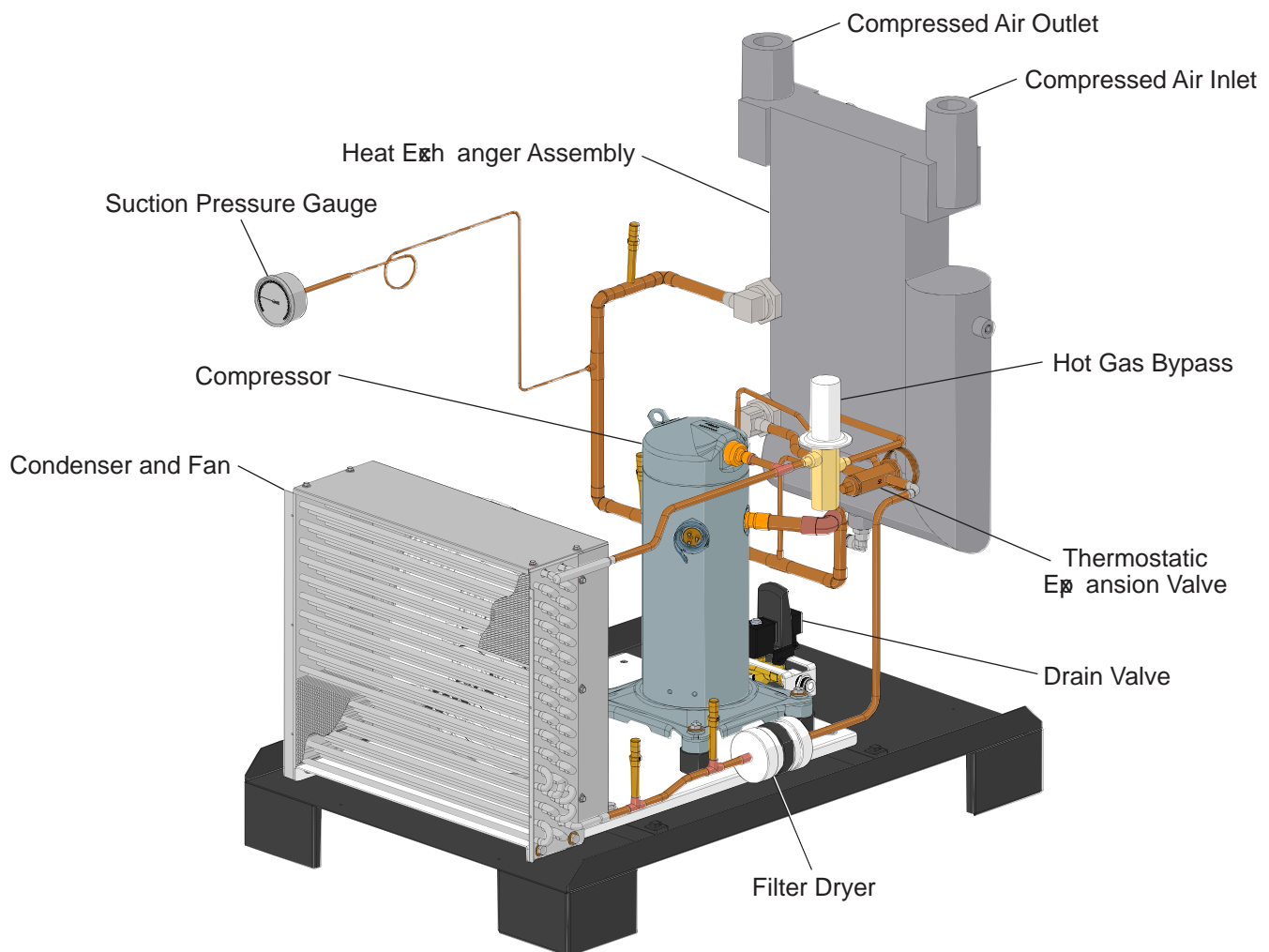
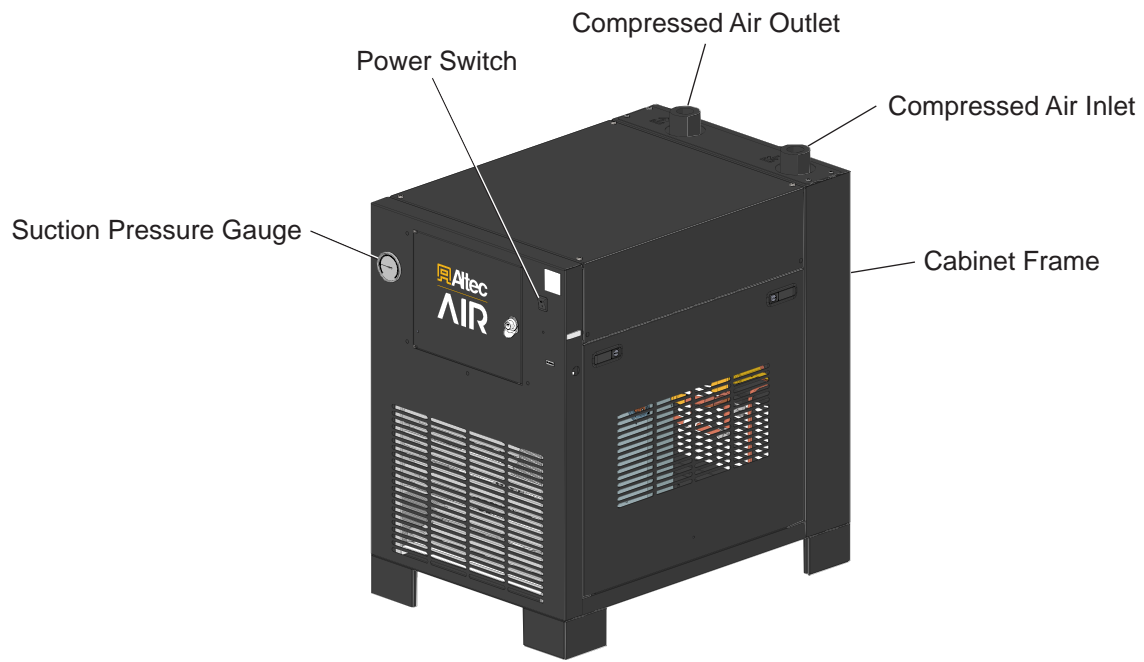

RAD-0250 and RAD-0300

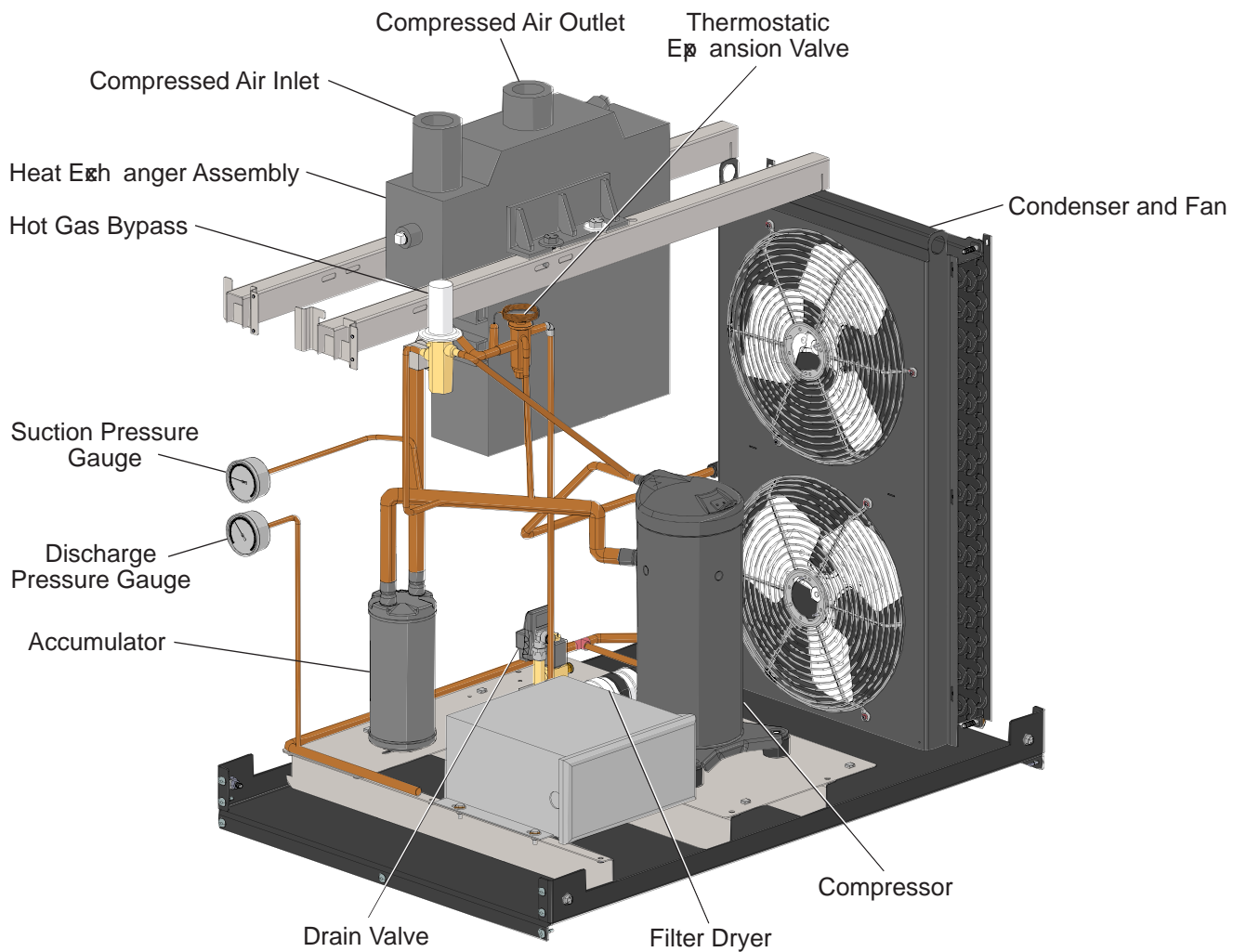
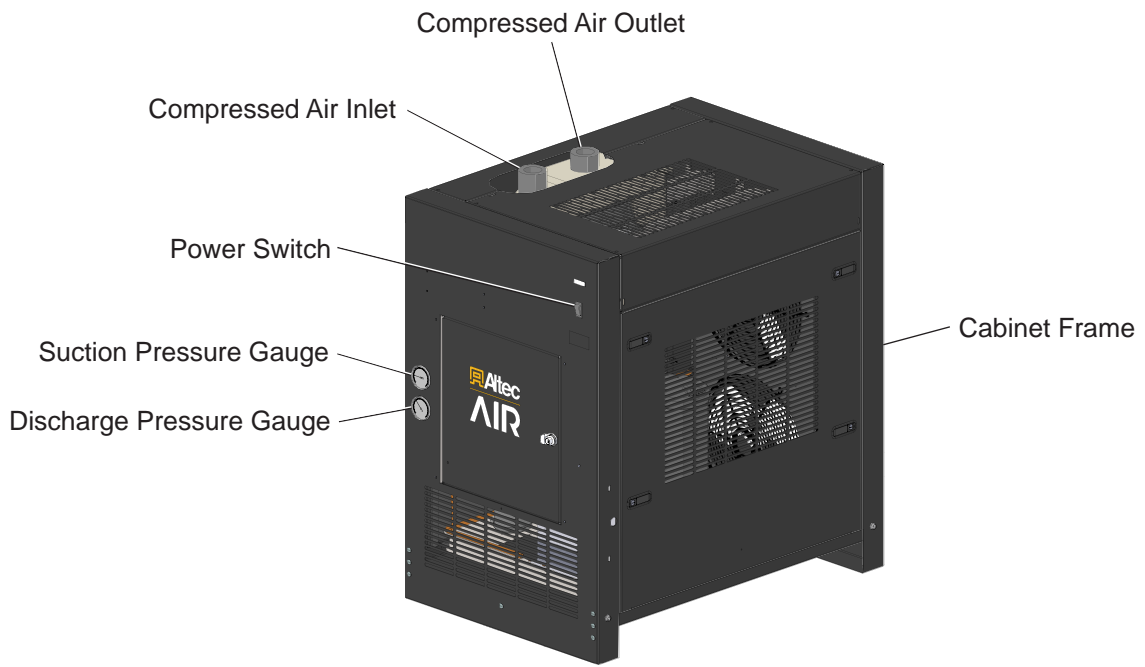

RAD-0400, RAD-0500, and RAD-0600

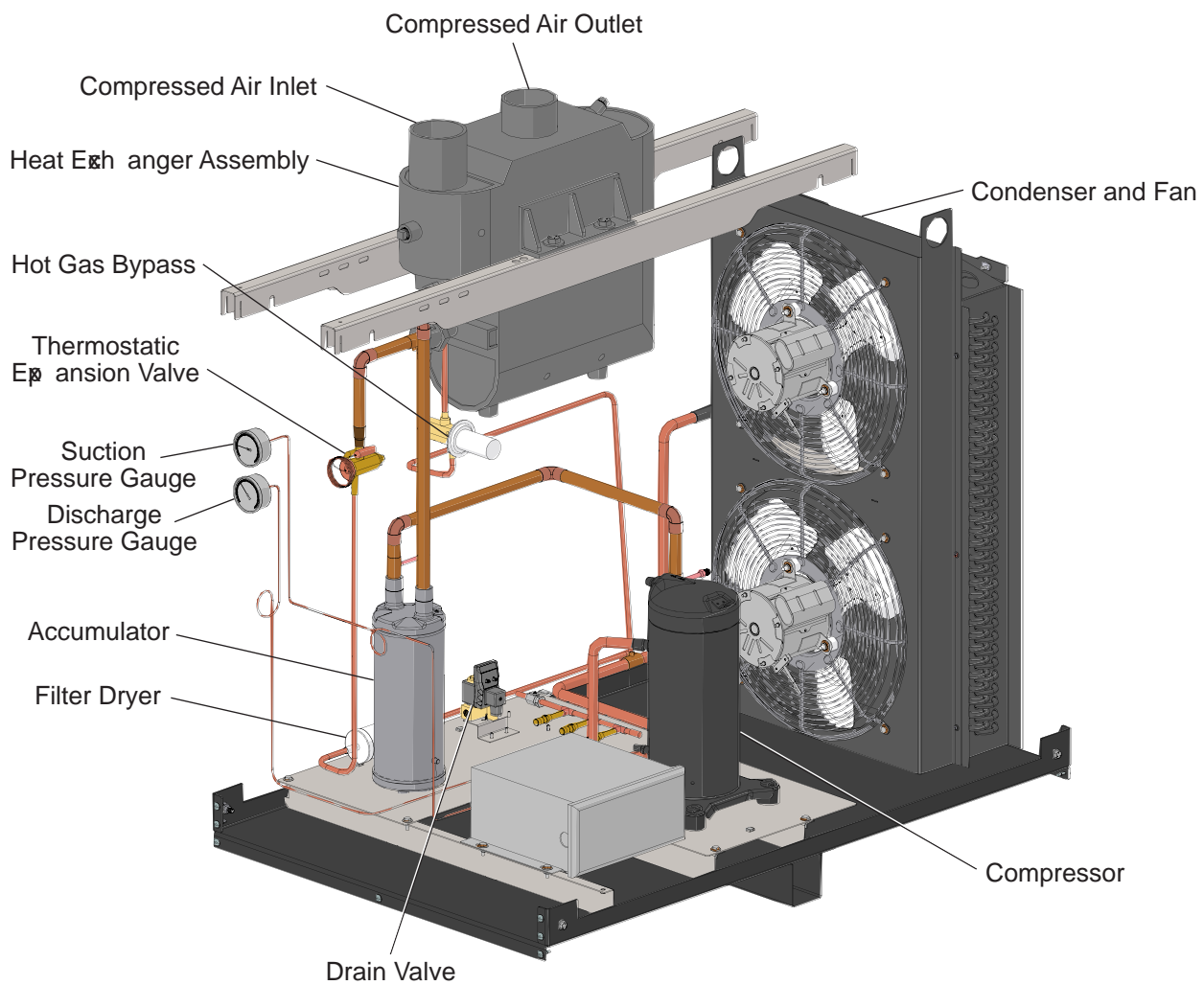
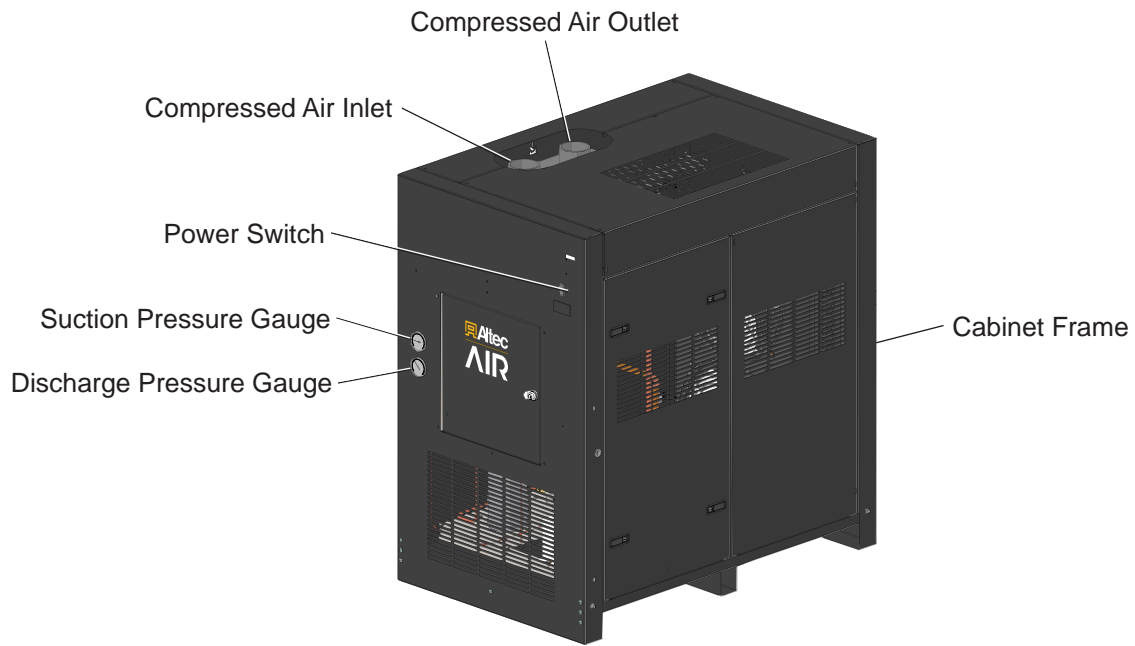

RAD-0750, RAD-1000, and RAD-1250

Section 3 — Safety

Safety Instructions

This section contains general information about safety and warning points to consider and adhere to during installation, operation, and maintenance of the air dryer. Read this section before performing any operation or procedure on the air dryer.

Safety alerts throughout this manual highlight situations in which accidents can occur. Pay special attention to all safety alerts.

WARNING

Follow all of the information in this manual to minimize the risk of electric shock, and prevent property damage or personal injury.

Stored energy may contain hazardous voltage. Be sure all capacitors are discharged before servicing the air dryer.

Avoid contact with live electrical circuits. Many procedures performed during installation, operation, testing, and maintenance of the air dryer require the air dryer to be energized, creating a situation for potential electric shock. Remove all jewelry before performing any procedures.

To avoid electrical overload and shock hazard, incoming power to the air dryer must be sized according to air dryer specifications.

CAUTION

Internal surfaces may be hot. Be careful when coming into contact with internal components as there is a potential for some of these components to become hot when in operation or standby.

Proper installation and maintenance as outlined in this manual is extremely important to ensure the reliability and longevity of the air dryer as well as prevent damage or personal injury.

Depressurizing the air dryer may be necessary before performing certain procedures.

NOTICE

Perform routine maintenance to ensure optimal performance over the life cycle of the air dryer. Performing procedures not recommended by Altec

AIR or installing components not supplied by Altec AIR is not recommended and may void the warranty.

General Operating Information

- Do not operate the air dryer without proper training and authorization.
- Use the air dryer for intended applications only.
- Be sure the air dryer is operating properly and has been inspected, maintained, and tested in accordance with Altec AIR's and the government's requirements.
- Ensure the manual is properly stored with the air dryer.
- Follow all employer regulations and safety rules and/or any state or federal law.

Air Dryer Electrical Information

WARNING

To avoid electrical overload and shock hazard, incoming power to the air dryer must be sized according to air dryer specifications.

Air dryer specifications can be found in Section 2 under General Specifications.

Disclaimer of Liability

Altec AIR is not liable for unauthorized alterations or modifications of the air dryer. Altec AIR is not liable for improper or abusive operation of the air dryer.

Do not alter or modify the air dryer in any way that might affect its structural integrity or operational characteristics without specific written approval from Altec AIR or an equivalent entity.

Unauthorized alterations or modifications will void the warranty. However, of greater concern is the possibility that unauthorized changes could adversely affect the air dryer's operation and could endanger personnel and/or damage property. Altec AIR is not responsible for unauthorized alterations or modifications that cause death, serious injury, and/or property damage.

Altec AIR assumes no liability for any personal injury and/or property damage related to the use of this manual when performing testing, operating, maintenance, and/or repair procedures on the Altec AIR air dryer.

Section 4 — Installation

Safety and Warning Information



WARNING

Avoid contact with live electrical circuits. Many procedures performed during installation, operation, testing, and maintenance require the air dryer to be energized, creating a situation for potential electric shock. Remove all jewelry before performing procedures.

The air dryer is not intended for use by persons (including children) with reduced physical, sensory, or mental capabilities, or lack of experience and knowledge, unless they have been given supervision or instruction concerning the use of the air dryer by a person responsible for their safety.

To avoid electric shock, damaged cords should be replaced by a qualified individual.

To avoid electrical overload and shock hazard, incoming power to the air dryer must be sized according to air dryer specifications.

Before You Begin

NOTICE

The air dryer should not be tilted on its side or upside down during shipping. Damage may occur if the air dryer is operated with insufficient oil in the compressor. If the air dryer has been tilted, let it sit upright for at least two hours before operation to avoid damage to the air dryer.

Upon arrival, check the air dryer for damage. Inspect the pressure gauge through the box cutout and ensure the gauge does not read zero. Review the data label and ensure proper electrical circuit to support voltage and amperage of the air dryer.

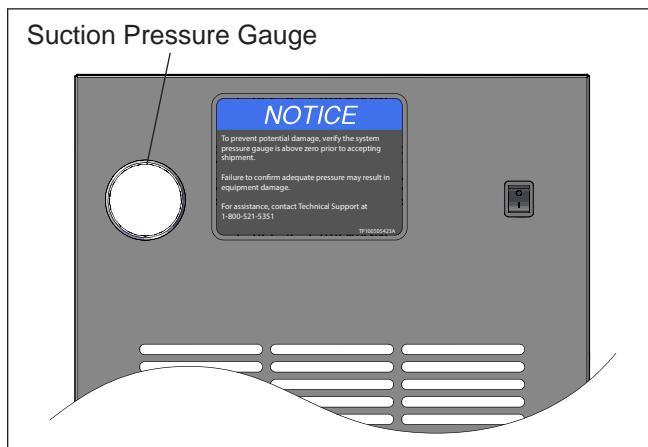

Figure 4.1 — Shipment Inspection

The air dryer must be installed in a well ventilated room that is free from dust, toxic gases, humidity, or pollution. Ambient temperatures must be at least 45 degrees Fahrenheit (7 degrees Celsius) and not exceed 120 degrees Fahrenheit (49 degrees Celsius).

Air dryers are designed to be installed on a concrete base capable of supporting the weight and forces from the air dryer operation. Remove the air dryer from the shipping pallet prior to installation.

Air dryers must be installed at least 3' (1 m) away from walls and any other equipment.

Do not run air through the air dryer without power to the air dryer on.

Do not mix inlet and outlet air flow. Pipe diameter should be sized according to the air flow requirement of the air dryer. Do not use the inlet and outlet of the air dryer to support the weight of the air piping.

A complete compressed air filter kit is recommended to protect the air dryer and downstream processes from contaminants found in the compressed air supply. Contact your Altec AIR representative for more information. Oil and particulates can damage the heat exchanger and reduce the air dryer efficiency.

A bypass may be installed on the air dryer outlet, inlet, and filtration to allow for bypassing, depressurizing, maintenance, and servicing of the air dryer.

Tubing must be secured as the condensate is discharged at the system pressure. Connect the condensate drain port to a collection point and dispose of condensate in compliance to local regulations. Condensate may contain oil particulates from the compressor air.

Consult with a licensed technician to ensure the electrical network and protection is sized properly. Ensure all fuses or breakers are correctly sized based on the data label information. For electrical data refer to Section 2.

Verify the data label for the proper electrical information prior to connecting the air dryer to the electrical supply.

Air dryers are equipped with either a power cord or terminal hookup locations. Refer to Section 2 under Air Dryer Specifications for plug type. Do not use socket adapters at the main plug. To identify the type of plug on the air dryer (refer to Figure 4.2).

Installation Configurations

These diagrams are general in nature and do not represent a specific unit configuration.

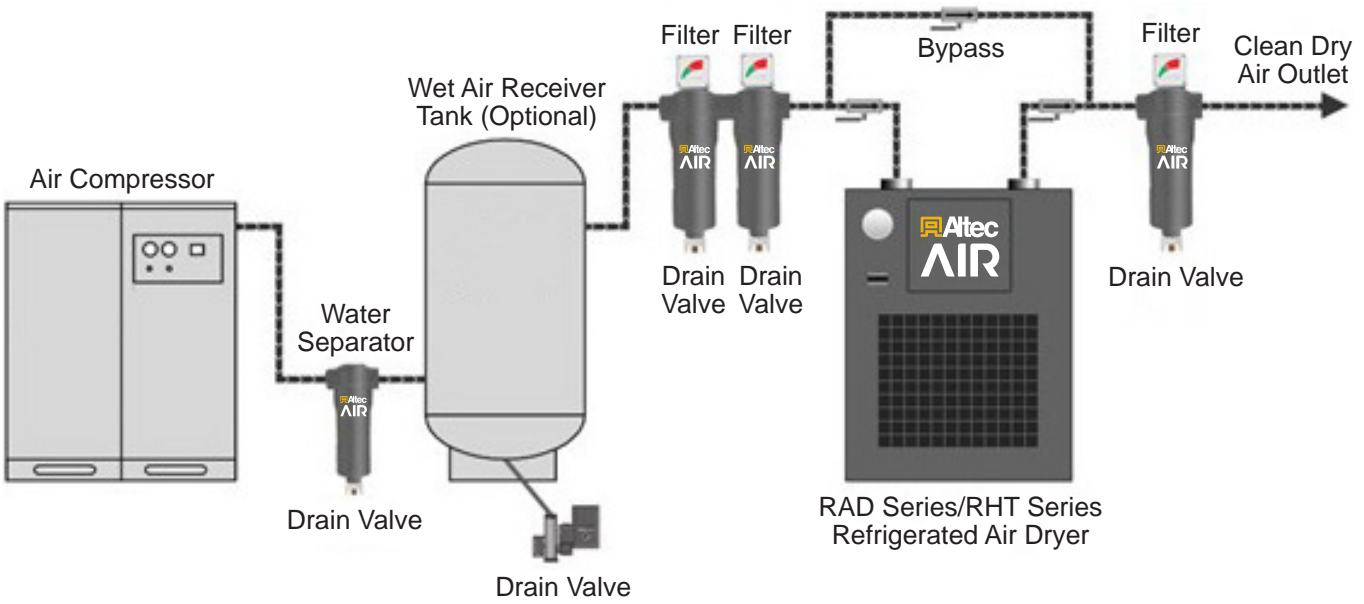

Wet Air Receiver Tank Set-Up

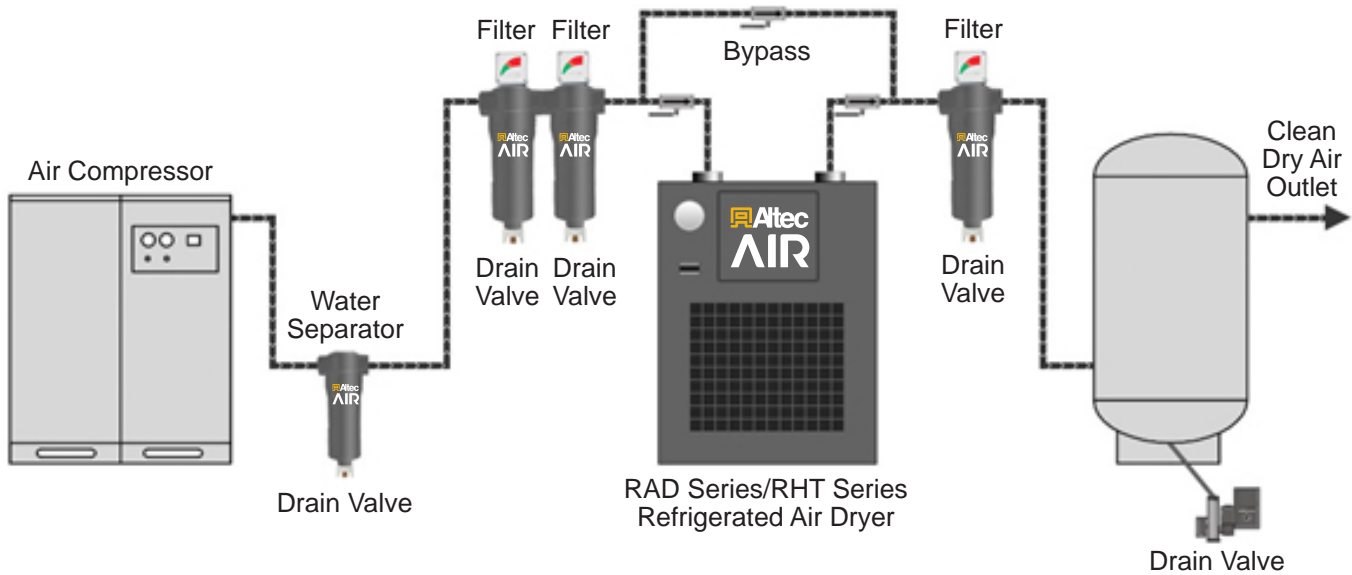

Dry Air Receiver Tank Set-Up

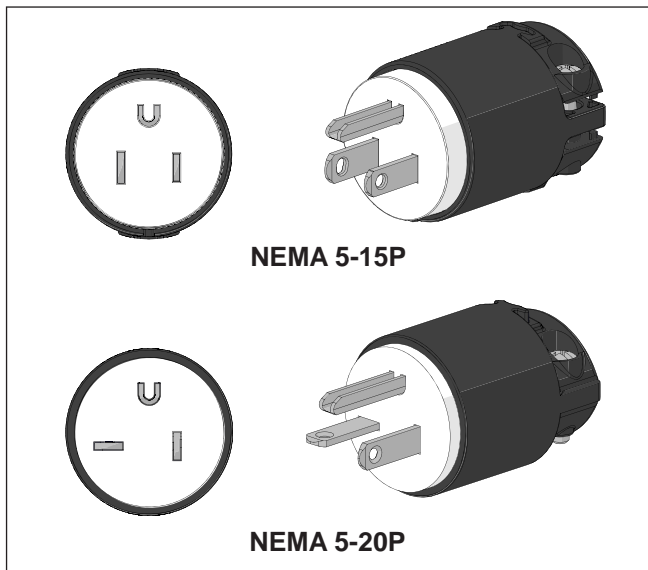

Figure 4.2 — Plug Types

Air dryers without a power cord included must be wired by a licensed technician according to the model specific Wiring Diagrams in the Appendix

If the air dryer is equipped with a programmable timer (option P), refer to Section 8 under Programming the P Series Timer prior to operating the air dryer.

Air Receiver Tank Setup

Wet air receiver tank setup is recommended for systems that consume less than or equal to the maximum capacity of the air compressor.

Dry air receiver tank setup is recommended for systems where the peak air consumption exceeds the flow rate of the air compressor. Tank capacity must be sized to compensate for the peak demand.

Items Included with the Air Dryer

- Manual
- Four latch keys RAD-0075 through RAD-1250 and RHT-0030 through RHT-0120

Required Tools and Materials

- Medium adjustable wrench
- Box cutter
- Cup of soapy water
- 1" paint brush (recommended)

Installation Procedure

1. Use a box cutter to remove the air dryer from the box and shipping materials. If any shipping damage is detected, file a claim with the shipping company prior to continuing the installation process.

WARNING

Avoid contact with live electrical circuits. Many procedures performed during installation, operation, testing, and maintenance require the air dryer to be energized, creating a situation for potential electric shock. Remove all jewelry before performing procedures.

2. Open the panel latches and remove one of the side panels.
3. Check for loose parts. Visually inspect the hoses, wiring, and copper tubing for leaks or cracks.
4. Place the air dryer at the desired operating location.
 - Place the air dryer on a level surface.
 - Ensure the air dryer is at least 3' (1 m) away in all directions from other equipment or walls.
5. Remove the plugs from the inlet and outlet air ports.
6. Install plumbing from the inlet and the outlet of the air dryer to the proper air compressor setup.
7. Route the condensate drain line to an environmentally approved disposal system in accordance with local, state, regional or territory codes and regulations.
8. Verify that the air dryer is powered off.
9. Verify the main electrical supply voltage matches the voltage on the data label and that proper circuit protection has been installed.
10. Plug the AC power cord to the air dryer or have a licensed technician wire the correct power to the air dryer with local, state, regional, or territory codes and regulations.

If equipped with a programmable timer, refer to Section 8 under Programming the P Series Timer.
11. Power the air dryer on.
12. Use soapy water and a paint brush to check for leaks in the air inlet and outlet plumbing.
13. Allow the air dryer to operate for 15 minutes.
14. Verify the refrigerant suction pressure. Refer to the data label to determine the type of refrigerant used.

- R134a air dryers are 28 to 34 PSIG
 - R404a air dryers are 74 to 80 PSIG
 - R449a air dryers are 62 to 67 PSIG
15. Verify the refrigerant discharge pressure (RAD-0250 and larger). Pressure will vary depending on operating and ambient conditions.
 - R449a air dryers are 110 to 275 PSIG
 16. Verify the condenser fan motors are operating.
 - *Fan 1 R449a dryers*
On at 250 PSIG, off at 200 PSIG
 - *Fan 2 R449a dryers*
On at 300 PSIG, off at 250 PSIG
 17. Confirm that condensate is discharging from the condensate drain based on drain valve time settings.
 18. Confirm that the condensate drain tubing is clear of obstructions.
 19. Check the dew point of the outlet air.
 20. Attach the refrigerant gauges.
 21. Check the evaporating pressure, suction, and discharge pressure.
 22. Use the wrench to adjust the hot gas bypass one quarter turn at a time to dial in the evaporator temperature between 33 and 37 degrees Fahrenheit (0.5 and 2.8 degrees Celsius). After each quarter turn, allow the air dryer to operate for five minutes.
 23. Reinstall the side panel. Lock all door latches to prevent access by unauthorized or untrained personnel.
 24. Register the air dryer (refer to Air Dryer Registration at the front of this manual).

Section 5 — Operation and Maintenance

WARNING

Avoid contact with live electrical circuits. Many procedures performed during installation, operation, testing, and maintenance require the air dryer to be energized, creating a situation for potential electric shock. Remove all jewelry before performing procedures.

The air dryer is not intended for use by persons with reduced physical, sensory, or mental capabilities, or lack of experience and knowledge, unless they have been given supervision or instruction concerning use of the air dryer by a person responsible for their safety.

Children must be supervised to ensure that they do not play with the air dryer.

To avoid electric shock, damaged cords should be replaced by a qualified individual.

To avoid electrical overload and shock hazard, incoming power to the air dryer must be sized according to air dryer specifications.

It is impossible to foresee all situations and combinations for installation of the air dryer. Establish criteria for safe operation of the air dryer based on actual conditions, work procedures, and experience. The owner and operator bear ultimate responsibility for ensuring that the air dryer is properly installed.

Air Dryer Access

Side Panel Removal

To remove the side panel, unlock the latches using the latch keys included with the air dryer or remove the fasteners holding the panels together. Press the latch down and pull out and up. To replace the side panel, line up the bottom tab and tilt the panel in. Press the latches down and use the key to lock them.

Top Panel Removal

To remove the top panel, remove both side panels. Then locate the four screws on the top and remove. Lift the panel straight up and off the air dryer.

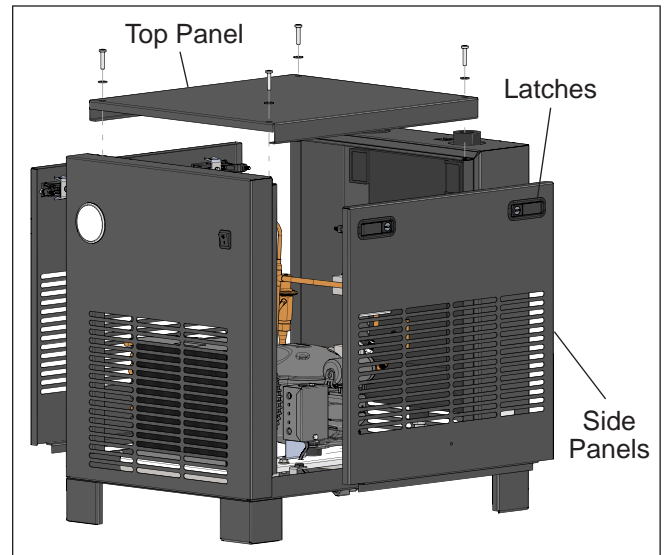

Figure 5.1 — Panel Removal

Refrigerant Manifold

Refer to the Functional Flow Diagrams to identify the high side/low side ports on the air dryer.

Use the following procedure to connect the refrigerant manifold to the air dryer.

1. Remove the low side and high side access valve caps.
2. Connect the blue tube of the refrigerant manifold to the low side access valve.
3. Connect the red tube of the refrigerant manifold to the high side access valve.
4. Open the refrigerant manifold valves on the high side and low side.
5. Ensure the correct refrigerant type is selected on the refrigerant manifold readout.

Important Measurements

- Evaporating temperature
- Low side pressure
- High side pressure

Functional Flow Diagrams

Functional flow diagrams provide detail about the flow of compressed air through the air dryer.

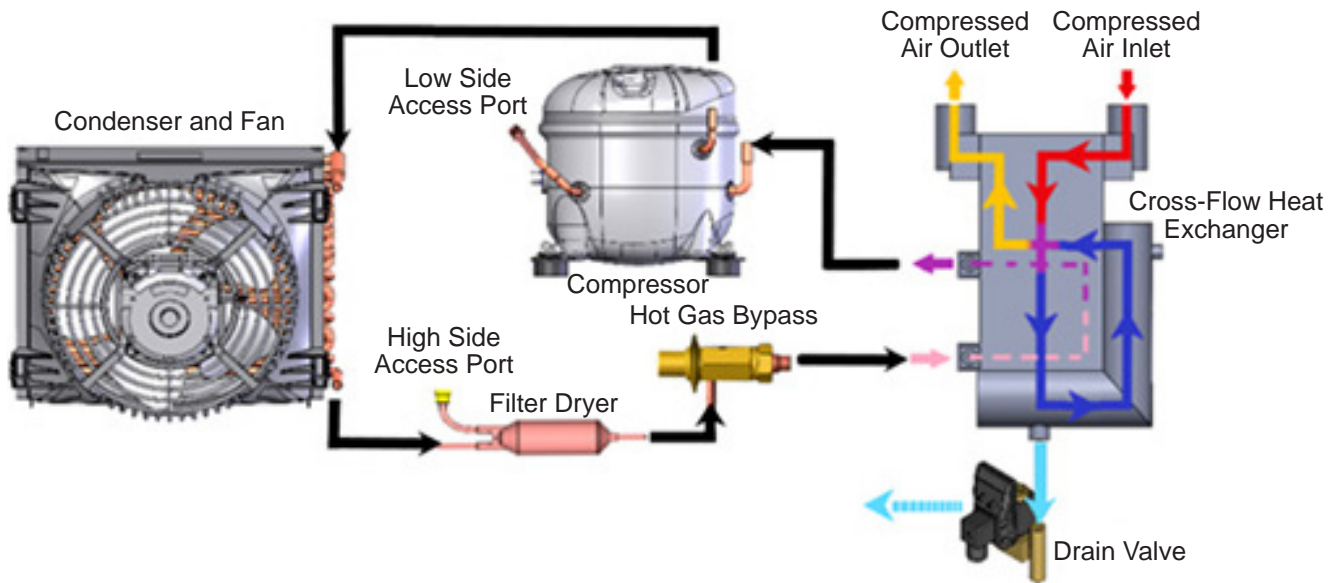

RAD-0025 through RAD-0055, RHT-0010 through RHT-0020

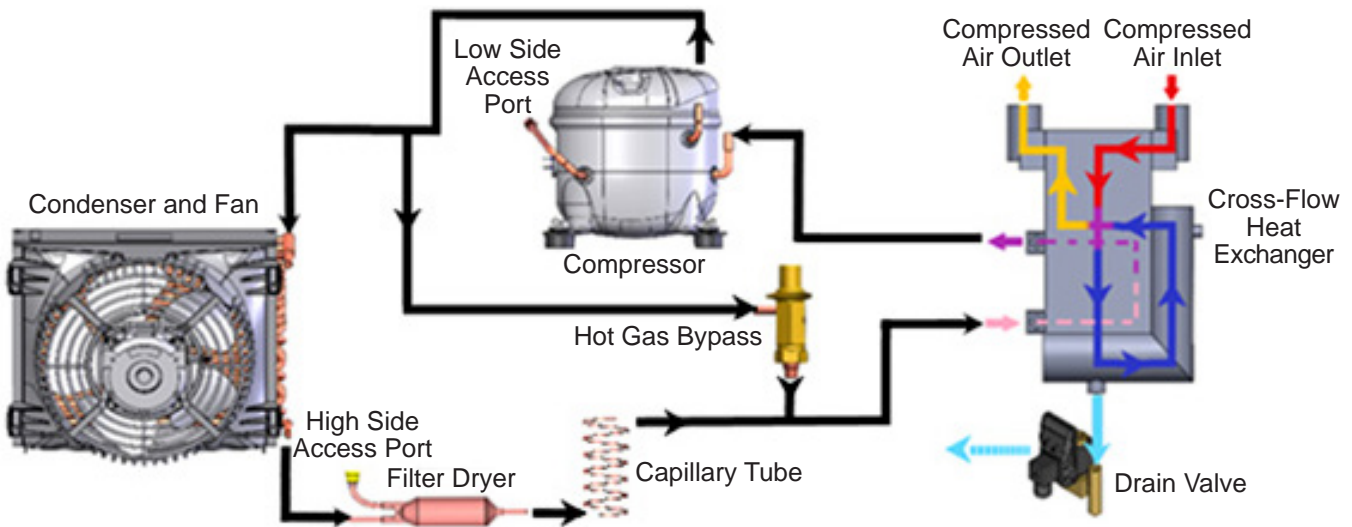

RAD-0075 through RAD-0200, RHT-0030 through RHT-0080

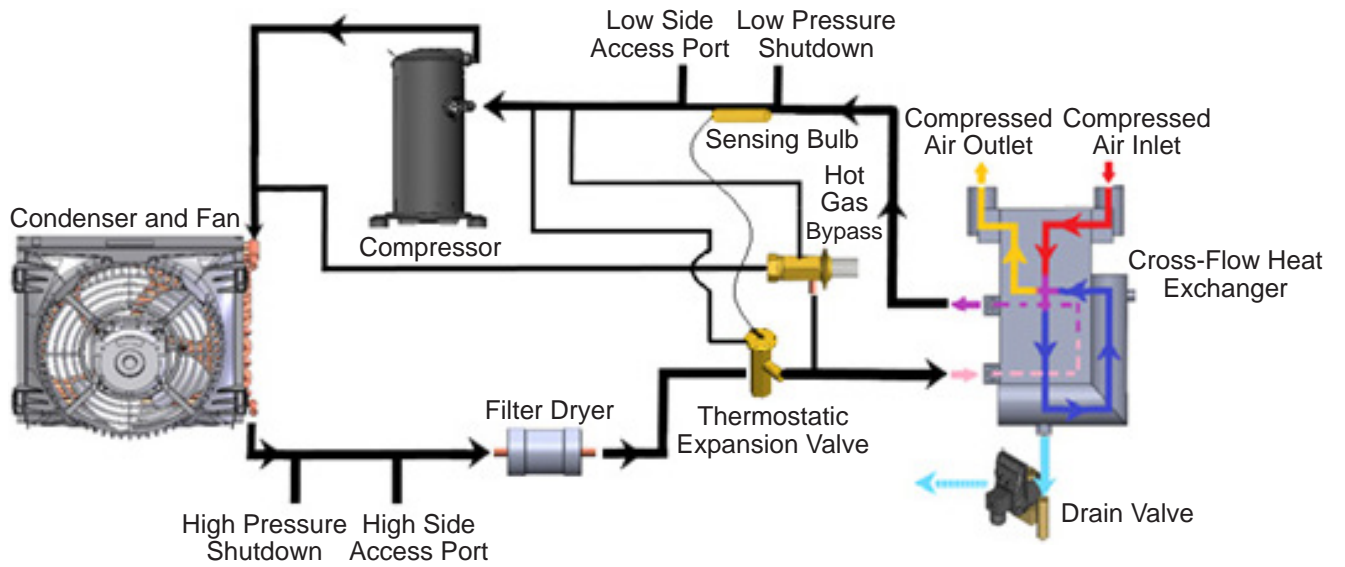

RAD-0250 through RAD-0300, RHT-0100 through RHT-0120

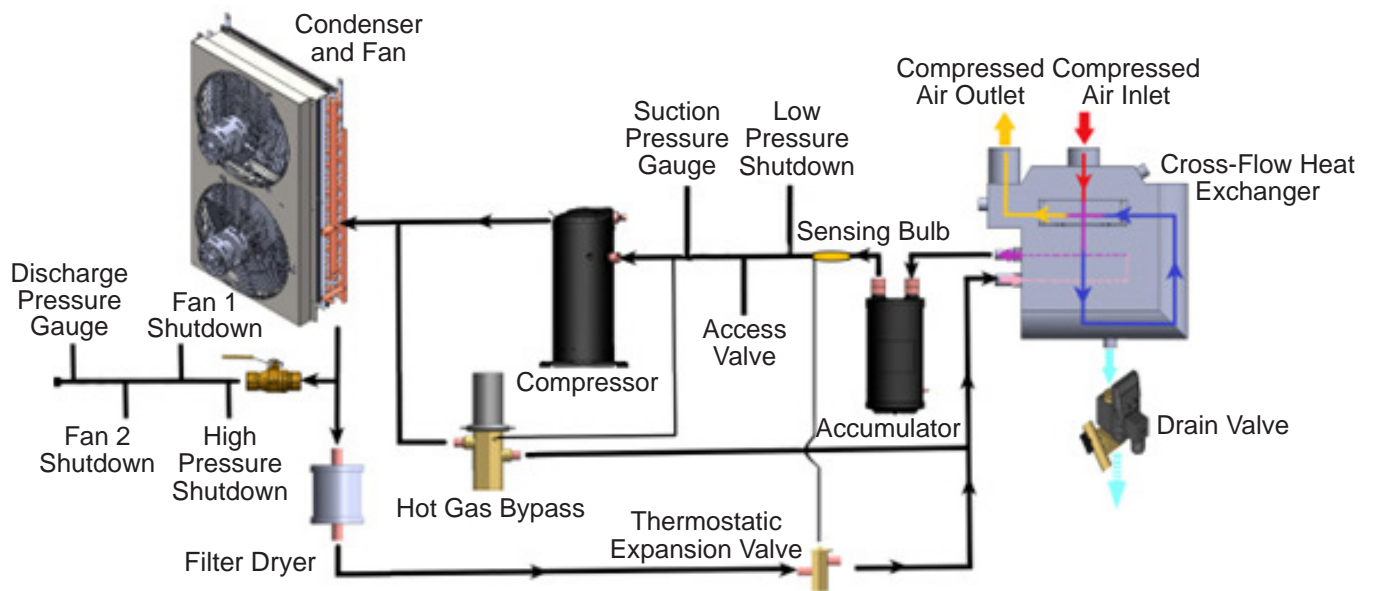

RAD-0400 through RAD-2000

Drain Valve

The drain valve removes condensed water from the air dryer that has been removed from the air in the heat exchanger. If the air dryer is equipped with the zero-loss drain (option Z), refer to Section 8 under Zero-Loss Drain.

To manually open the drain valve, press the test button. The drain valve open (on) time is adjustable from 0.5 to 10 seconds. The default setting is 6 seconds. When the drain valve opens, the on light turns on. To change the open time, twist the knob labelled Sec to the desired time.

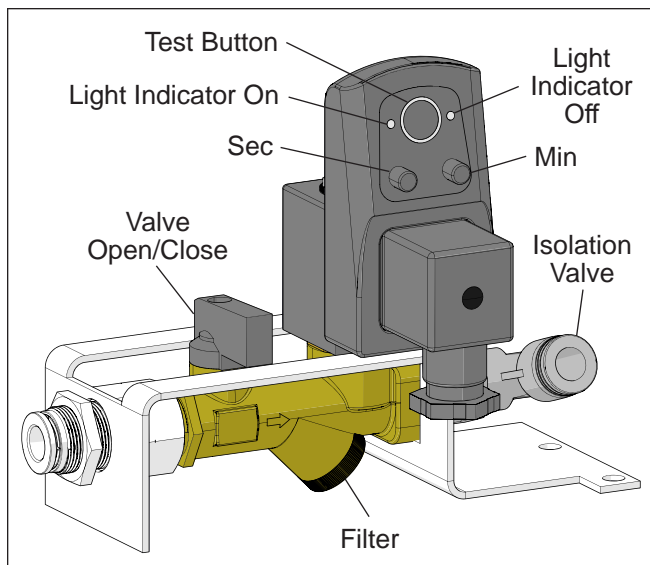

Figure 5.2 — Drain Valve

The drain valve closed (off) time is adjustable from 0.5 to 45 minutes. The default setting is 10 minutes. When the drain valve is closed, the off light turns on. To change the closed time, twist the knob labelled Min to the desired time.

To clean the drain valve, close the isolation valve. Press the test button to release the pressure. Remove the filter from the bottom of the isolation valve by twisting off the threaded base and pulling out the filter. Clean the filter and replace. Open the drain valve and resume normal operation.

Hot Gas Bypass Valve

The hot gas bypass valve regulates the evaporating temperature based on refrigerant pressure. Use the following procedure to adjust the evaporating temperature with the hot gas bypass valve.

Adjustment

1. Attach refrigerant gauges to the air dryer.
2. Allow the air dryer to operate for 15 minutes after running under the compressed air load.

3. Open the side panel that allows for the easiest access to the hot gas bypass valve.
4. Remove the black rubber cap from the hot gas bypass valve.
5. Note the initial evaporating temperature value shown on the refrigerant gauges.
6. Turn the hot gas bypass valve hex head adjusting screw one quarter turn.

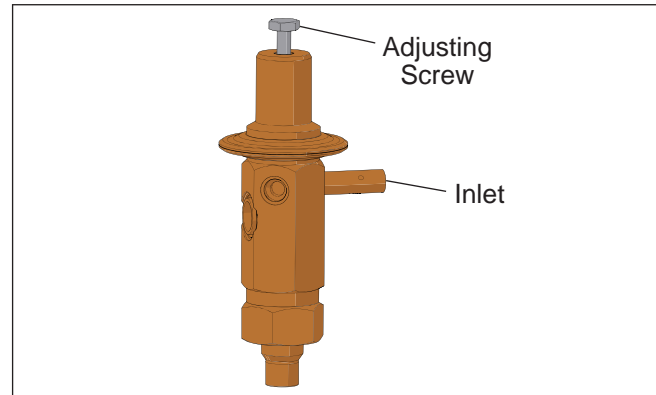

Figure 5.3 — Hot Gas Bypass Valve

7. Allow the air dryer to operate five minutes.
8. Note the new evaporating temperature.
9. Continue to adjust the hot gas bypass valve until the evaporating temperature is between 33 and 37 degrees Fahrenheit (0.5 and 2.8 degrees Celsius).
10. Replace the black rubber cap, remove the refrigerant gauges, and replace the air dryer side panel.

Thermostatic Expansion Valve

The thermostatic expansion valve controls the amount of superheat. Superheat is the difference between the actual temperature of the vapor and its saturation temperature at a given pressure. Superheat ensures the refrigerant has completely vaporized before entering the compressor.

Use the following procedure to adjust the thermostatic expansion valve.

Adjustment

1. Use a wrench to turn the hex nut one quarter turn at a time to adjust.
2. Allow the air dryer to operate for five minutes prior to adjusting further.

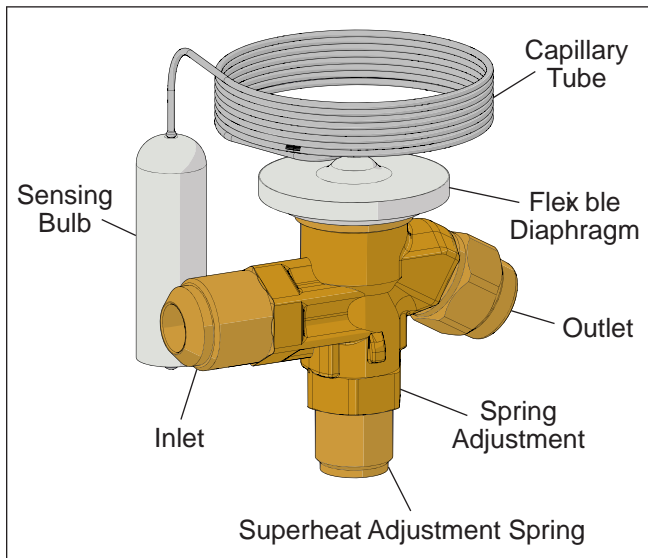

Figure 5.4 — Thermostatic Expansion Valve

Condenser and Fan

The condenser and fan cool the hot gas from the compressor into a liquid (refer to Figure 5.5).

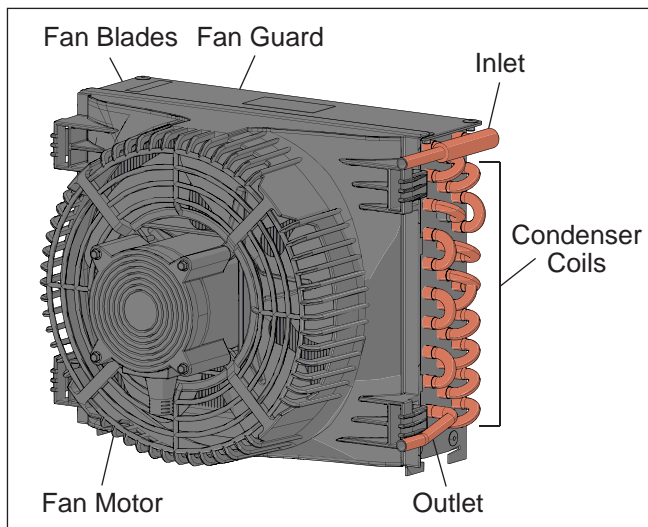

Figure 5.5 — Condenser and Fan

Clean the air-cooled condenser coils once per week to ensure the dryer continues to operate efficiently. The condenser coil between the hot air bypass and the filter dryer also must be checked once per week to make sure it is clean and unobstructed.

Cleaning

1. Open both side panels of the air dryer and top panel if necessary to reach the air-cooled condenser coils.

2. Blow clean pressurized air into the fins of the condenser coils from the front and top as accessible. Be careful not to bend fins in the process.

3. Replace the air dryer panels.

Compressor

The compressor draws in refrigerant and compresses it to a gas. The type of compressor installed in the air dryer will vary by model (refer to Figure 5.6).

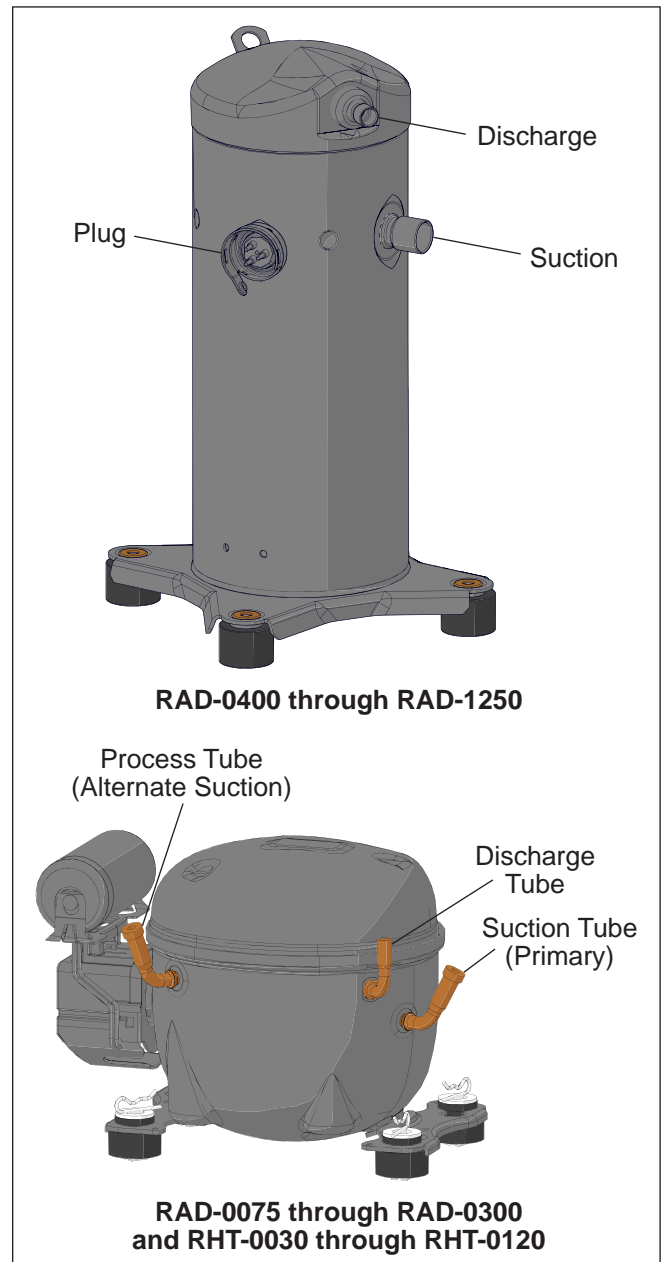

RAD-0400 through RAD-1250

RAD-0075 through RAD-0300 and RHT-0030 through RHT-0120

Figure 5.6 — Compressors

Accumulator

The accumulator prevents liquid refrigerant from entering the compressor (refer to Figure 5.7).

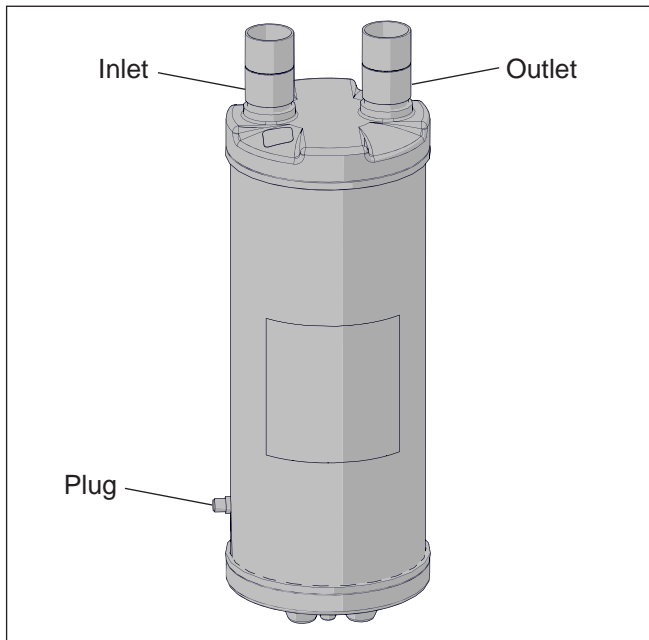

Figure 5.7 — Accumulator

Cross-Flow Heat Exchanger

The cross-flow heat exchanger exchanges thermal energy from the air to the refrigerant. As part of the process, the heat exchanger removes condensed water from the dryer through the drain valve (refer to Figure 5.8).

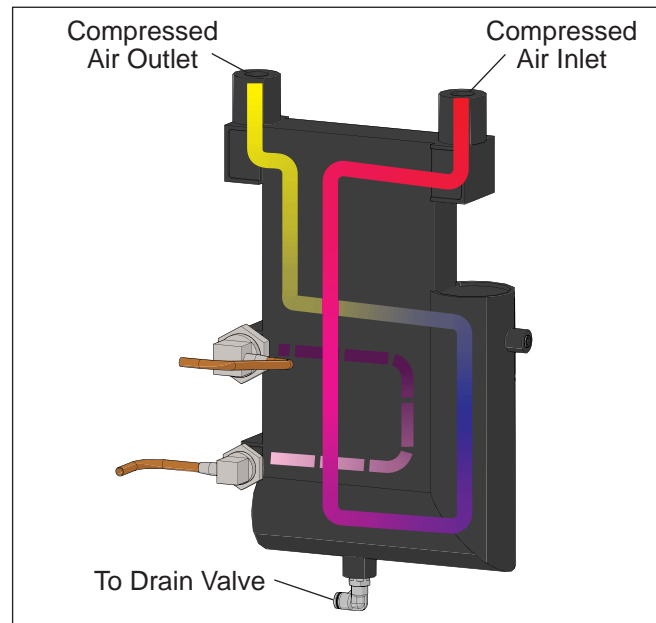

Figure 5.8 — Cross-Flow Heat Exchanger

Maintenance

To ensure the air dryer continues to operate efficiently and reliably, inspect and maintain the following components at the specified time intervals (refer to Figure 5.9).

WARNING

Avoid contact with live electrical circuits. Many procedures performed during installation, operation, testing, and maintenance require the air dryer to be energized, creating a situation for potential electric shock. Remove all jewelry before performing procedures.

Time Frame	Maintenance Operation	Refer To
Daily	Check the automatic drain valve operation once per eight-hour shift.	Drain Valve Operation
Weekly	Make sure the suction pressure gauge is in proper range.	Section 4 — Installation Procedure
	Make sure the condenser coil is clean and unobstructed.	Condenser and Fan
Monthly	Clean the automatic drain valve.	Drain Valve Operation
	Check the compressed air filter differential.	The filter manufacturer
	Replace pre and post filtration elements (if necessary).	The filter manufacturer

Figure 5.9 — Routine Maintenance



CAUTION

Internal surfaces may be hot. Use care when coming into contact with internal components as there is a potential for some of these components to become hot when in operation or standby.

It may be necessary to depressurize the air dryer before performing certain procedures.

NOTICE

Air dryer failure due to a dirty condenser is not covered under warranty.

Section 6 — Troubleshooting

Before Calling Altec AIR

Read this section to diagnose and attempt to fix the problem with the air dryer before placing a call to Altec AIR Technical Support.

This information is intended to simplify the isolation of problems, present possible causes, provide test procedures for verification, and suggest corrective action to restore the air dryer to normal operation. Each section begins with the most likely cause(s) of the issue. Otherwise, start from the simplest possibilities and progress to more complicated ones.

This information is designed to be easy to follow and is effective when used properly. Start at the beginning of the specific problem section and continue in sequence, following the procedures indicated.

Troubleshooting Procedure

Establish a troubleshooting procedure to be followed any time there is a malfunction. This procedure will provide a starting point for determining the root cause of the malfunction and increase troubleshooting accuracy. Consider using the following procedure.

1. Use the Functional Flow Diagrams in Section 5 and the Wiring Line Diagrams in the Appendix to determine the flow path required to operate the failed function. Make a list of the components used to operate the failed function. Cross off components used to operate other functions that are operating properly. This should minimize the number of items to check.
2. Check the easiest component first. Verify the proper operation of each component remaining on the list until the bad component is found.
3. Use accurate test equipment to verify temperature, flow, pressure, voltage, and current.

Once the symptom has been positively identified, use the Troubleshooting Chart in the Appendix for suggested causes and corrective actions.

WARNING

Follow all of the information in this manual to minimize the risk of electric shock, and prevent property damage or personal injury.

Internal surfaces may be hot. Use care when coming into contact with internal components as there is a potential for some of these components to become hot when in operation or standby.

Avoid contact with live electrical circuits. Many procedures performed during installation, operation, testing, and maintenance require the air dryer to be energized, creating a situation for potential electric shock. Remove all jewelry before performing procedures.

CAUTION

It may be necessary to depressurize the air dryer before performing certain procedures.

NOTICE

Perform routine maintenance to ensure optimal performance over the life cycle of the air dryer. Performing procedures not recommended by Altec AIR or installing components not supplied by Altec AIR is not recommended and may void the warranty.

Contacting Altec AIR Technical Support

If additional assistance is needed to correct a problem, contact Altec AIR Technical Support at (800) 521-5351 (option 1).

You will need the model number and serial number, which can be found on the data label.

If you are following-up on a previous call, have the ticket number available.

Section 7 — Parts

Introduction

Altec AIR provides parts to replace the individual components of the air dryer. The following charts show the

required part number to replace each part by model. Use the single phase air dryers table if the model number ends in 1 or 2. Use the three phase air dryers table if the model number ends in 3, 4, or 5.

Single Phase Air Dryers

Description	Part No.	RAD-0025A-1	RAD-0040A-1	RAD-0055A-1	RAD-0075A-1	RAD-0075A-2	RAD-0100A-1	RAD-0100A-2	RAD-0150A-1	RAD-0150A-2	RAD-0200A-1	RAD-0200A-2
Heat exchanger assembly	100514889	X										
	100514875		X	X								
	100514891				X	X	X	X				
	100514898								X	X	X	
	100521723											X
	100513579	X										
Heat exchanger	100513571		X	X								
	100513568				X	X	X	X				
	100513569								X	X	X	X
	100513518	X	X	X								
Hot gas bypass	100513519				X	X	X	X	X	X		
	100513276										X	X
	100513517				X	X	X	X	X	X	X	X
Suction pressure gauge	100511199	X	X	X	X	X	X	X	X	X	X	X
Condensing unit	100514868	X	X									
	100510803			X								
	100510802				X							
	100514867					X						
	100510792						X					
	100510794							X				
	100510796								X			
	100510797									X		
	100514881										X	
	100510763											X
Compressor	100518790	X	X									
	100510955			X								
	100510956				X							
	100518795					X						
	100510933						X					
	100518800							X				
	100510971								X			
	100514452									X		
	Note ¹										X	
	100514806											X
Condenser coil	100518791	X	X									
	100514455			X	X							
	100518796					X						
	100514456						X					
	100518801							X				
	100514457								X	X		
	Note ¹										X	
	100514807											X

¹Call Altec AIR for replacement part number.

Description	Part No.	RAD-0025A-1	RAD-0040A-1	RAD-0055A-1	RAD-0075A-1	RAD-0075A-2	RAD-0100A-1	RAD-0100A-2	RAD-0150A-1	RAD-0150A-2	RAD-0200A-1	RAD-0200A-2	
Fan motor	100518792	X	X										
	100510926			X	X								
	100518797					X							
	100510873						X						
	100518802							X					
	100510874								X				
	100510838									X			
	Note ¹											X	
	100510840												X
	Fan blade	100518793	X	X									
100514462				X									
100514460					X								
100518798						X							
100514463							X						
100518803								X					
100510893									X	X		X	
Note ¹												X	
Fan guard	100518794	X	X										
	100514465			X									
	100510885				X								
	100518799					X							
	100514466						X						
	100518804							X					
	100514472								X	X			
	Note ¹											X	
Drain valve	100521866	X	X	X	X		X		X		X		
	100513117					X		X		X		X	
Power cord	100518728	X	X	X	X	X	X	X				X	
	100520958								X	X	X		
Power plug	100512710								X		X		
Power switch	100514964	X	X	X	X	X	X	X	X	X	X	X	
Filter dryer	100513398	X	X	X	X	X	X	X	X	X			
	100513377										X	X	
HE cover plate	100514911	X											
	100514912		X	X									
Rubber foot	100516244	X	X	X									
Drain bulkhead	100518729	X	X	X	X	X	X	X	X	X	X	X	

¹Call Altec AIR for replacement part number.

Three Phase Air Dryers

Description	Part No.	RAD-0250A-3	RAD-0250A-4	RAD-0250A-5	RAD-0300A-3	RAD-0300A-4	RAD-0300A-5	RAD-0400A-3	RAD-0400A-4	RAD-0400A-5	RAD-0500A-3	RAD-0500A-4	RAD-0500A-5	RAD-0600A-3	RAD-0600A-4	RAD-0600A-5	RAD-0750A-4	RAD-0750A-5	RAD-1000A-4	RAD-1000A-5	RAD-1250A-4	RAD-1250A-5	
Heat exchanger assembly	100515026	X	X	X																			
	100515033				X	X	X																
	100520385							X	X	X													
	100520388										X	X	X										
	100520375													X	X	X							
	100520497																X	X					
	100520632																			X	X		
	100520633																					X	X
Hot gas bypass	100513276	X	X	X	X	X	X																
	100513384							X	X	X	X	X	X	X	X	X							
High pressure shutdown	100513517	X	X	X	X	X	X	X	X	X	X	X	X	X	X	X	X	X	X	X	X	X	X
Suction pressure gauge	100511200	X	X	X	X	X	X	X	X	X	X	X	X	X	X	X							
Discharge pressure gauge	100511197							X	X	X	X	X	X	X	X	X	X	X	X	X	X	X	X
Compressor	100521022	X			X																		
	100521026		X	X		X	X																
	100520344						X			X													
	100520412							X	X		X	X											
	100520413													X									
	100520335														X	X							
	100520486																X	X					
	100520634																			X	X		
100520487																					X	X	
Condenser coil	100510819	X	X	X	X	X	X																
	100514561							X	X	X	X	X	X	X	X	X							
	100520501																X	X	X	X	X	X	X
	100510848	X	X	X	X	X	X			X			X										
	100510839							X	X		X	X		X	X								
Fan blade	100510825	X	X	X	X	X	X	X	X	X	X	X	X	X	X	X							
Fan guard	100514467	X	X	X	X	X	X																
	100510834							X	X	X	X	X	X	X	X	X							
Drain valve	100521866		X	X		X	X																
	100521299							X	X	X	X	X	X	X	X	X	X	X	X	X	X	X	X
	100513117	X			X																		
Fan switch	100513516						X	X	X	X	X	X	X	X	X	X	X	X	X	X	X	X	X
Fuse block	100512189								X			X			X		X		X		X		X

Description	Part No.	RAD-0250A-3	RAD-0250A-4	RAD-0250A-5	RAD-0300A-3	RAD-0300A-4	RAD-0300A-5	RAD-0400A-3	RAD-0400A-4	RAD-0400A-5	RAD-0500A-3	RAD-0500A-4	RAD-0500A-5	RAD-0600A-3	RAD-0600A-4	RAD-0600A-5	RAD-0750A-4	RAD-0750A-5	RAD-1000A-4	RAD-1000A-5	RAD-1250A-4	RAD-1250A-5	
Power switch	100514964	X	X	X	X	X	X	X	X	X	X	X	X	X	X	X	X	X	X	X	X	X	X
Filter dryer	100513377	X	X	X	X	X	X																
	100513379							X	X	X	X	X	X	X	X	X							
HE cover plate	100514830	X	X	X																			
	100514602				X	X	X																
Accumulator	100513169							X	X	X	X	X	X	X	X	X							
	100513174																	X	X	X	X	X	X
Drain bulkhead	100518729	X	X	X	X	X	X																
	Note ¹							X	X	X	X	X	X	X	X	X	X	X	X	X	X	X	X
Thermostatic expansion valve	100520504	X	X	X	X	X	X	X	X	X													
	100520456										X	X	X	X	X	X							
	100520502																	X	X				
	100520503																			X	X	X	X
Low pressure shutdown	100513395	X	X	X	X	X	X	X	X	X	X	X	X	X	X	X	X	X	X	X	X	X	X
Transformer 460/575 VAC	100512862			X			X																
	100512863									X			X			X							
	100512866																	X		X			X
Transformer 230/460 VAC	100513138		X	X		X	X		X	X		X	X		X	X	X	X	X	X	X	X	X
Contactator 120 VAC	100510862		X	X		X	X		X	X		X	X		X	X	X	X	X	X	X	X	X
Contactator 230 VAC	100510861	X			X			X			X			X									

¹Call Altec AIR for replacement part number.

Section 8 — Options

The air dryer may be configured with additional options. A letter added to the end of the model name indicates which option is equipped. These include a digital scroll compressor (D), programmable timer (P), or zero-loss drain (Z).

Digital Scroll Compressor

On air dryers equipped with a digital scroll compressor, the closed loop digital controller (refer to Figure 8.1) monitors the refrigeration system high side and low side pressures, cycles the condenser fan motors on and off, and loads and unloads the digital scroll compressor based on the current heat load (air flow) going through the dryer.

The controller is preset at the factory. No adjustments are necessary or should be made.

Programmable Timer

Programming the P Series Timer

The P Series timer lets the user program when and how long the air dryer operates. Figure 8.2 shows the layout of the timer's keypad and display. For information on the functions of the keypad, refer to Figure 8.3.

DATE and DST must be set in regions where daylight saving time is observed. The clock rolls ahead from 02:00

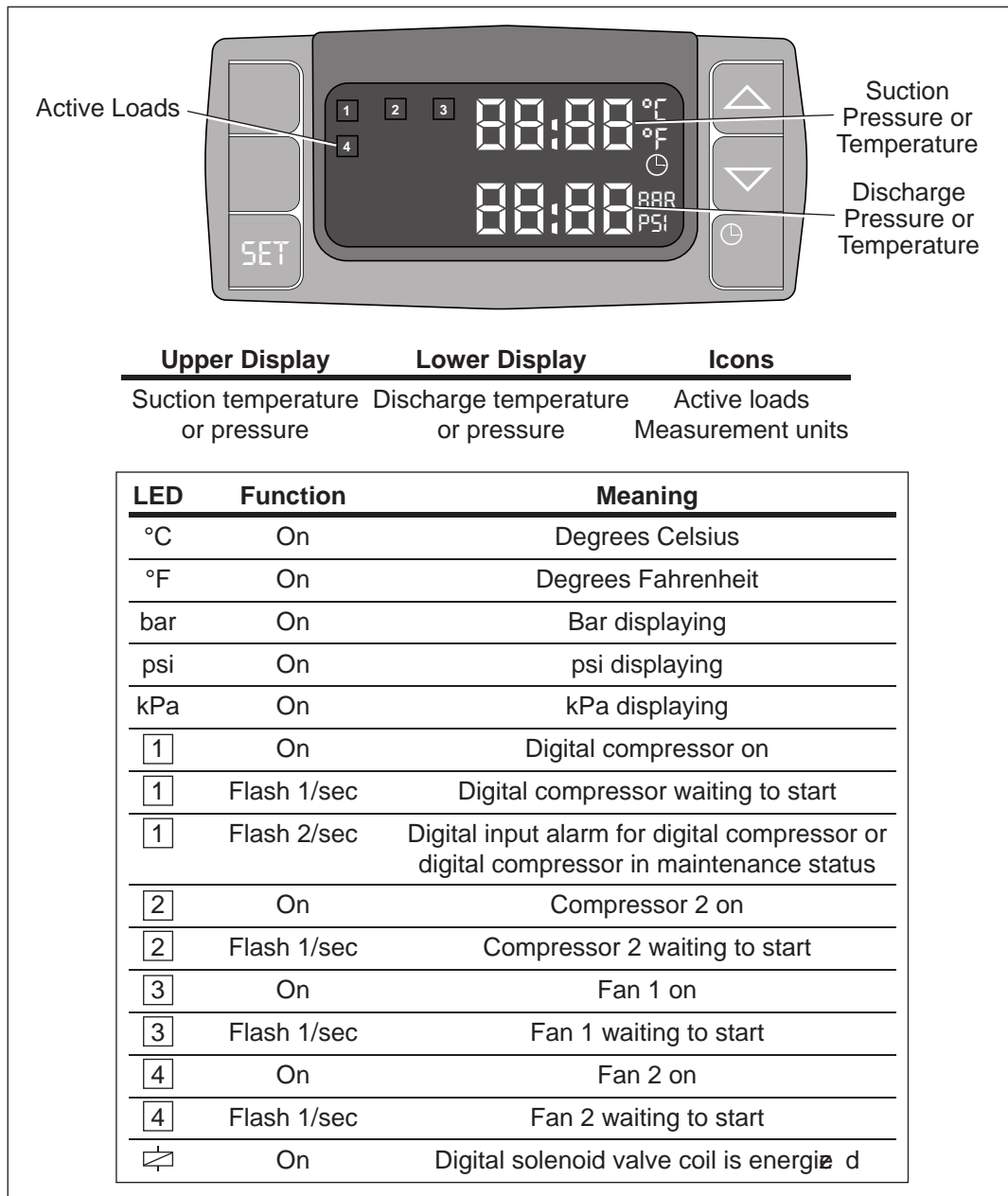

Figure 8.1 — Closed Loop Digital Controller

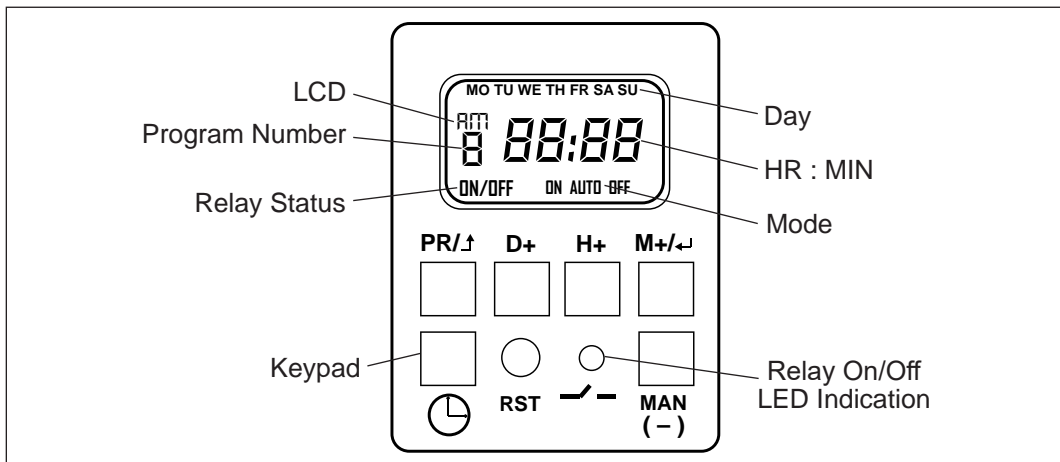

Figure 8.2 — Timer (Front View)

Symbols	Description
PR / ↑	Program key to view and edit programs and as an ESC key
D+	Day selection and as a date/DST increase key
H+	Hour selection and as a date/DST decrease key
M+ / ↵	Increment minute and as an enter key
(H+) + (M+)	Enter date/DST mode
RST	Reset programs and settings in the device
MAN (-)	Manual key for overriding and to decrease D/H/M in program mode
	Clock key to set the clock
+ MAN	Set 12/24 hour clock mode
+ PR	Lock/unlock keypad
+ MAN	Press the clock key and MAN key simultaneously to toggle between 12/24 hour clock mode AM/PM
+ D+	Keep the clock key pressed, then press the D+ key to set the day MO/TU/WE/TH/FR/SA/SU
+ H+	Keep the clock key pressed, then press the H+ key to set the hour 00 - 23 IN 24 hour mode 01 - 12 IN 12 hour mode
+ M+	Keep the clock key pressed, then press M+ key to set minute 00-59

Figure 8.3 — Keypad Functions

to 03:00 at the start of DST and rolls back from 03:00 to 02:00 at the end of DST.

When the DST period starts, the clock rolls ahead by one hour. If the user has set the clock prior to setting DST and accounted for the additional hour, the clock may require adjustment.

The timer may be used to set up to 25 individual programs. For programming details, refer to Figure 8.4.

- During run mode, press H+ with M+ to enter the date menu. Press M+ / to enter the menu. Edit YY, Πt and dt using D+ or H+.
- The date menu is being displayed, press H+ or D+ to select DST and press M+ / to enter its menu.
- The user can enter DST and the date as shown (refer to Figure 8.5).

25 On/Off Programs

1 2 3 4 5 6 7 8 9 A B C D e f G H J L n P q T u Y

Screen 1  After power on, screen 1 will be displayed.

Screen 2  Set the current time (10:00), day (Friday), and relay mode (auto) as per clock setting and mode function.

PR /  Press PR to enter on/off time program.

Screen 3  Press D+ stepwise for day selection as follows. Monday to Sunday is default setting.

1. MO TU WE TH FR SA SU (All weekdays)
2. MO TU WE TH FR SA (Exclude Sunday)
3. MO TU WE TH FR (Exclude weekends)
4. MO TU WE TH SU (Exclude Friday and Saturday)
5. SA SU (Only weekends)
6. FR SA (Only weekends)
7. TU WE TH FR SA SU (Exclude any single day)
8. MO / TU / WE / TH / FR / SA / SU (Include any single day)
9. MO WE FR SU (Exclude alternate days)
10. TU TH SA (Exclude alternate days)

Screen 4  Press H+ to edit and increase the hour as needed; use MAN (-) key to decrease hours.

Screen 5  Press H+ to edit and increase the hour as needed; use MAN (-) key to decrease hours.

To save and exit the program, press the  key.

Figure 8.4 — Programming Details

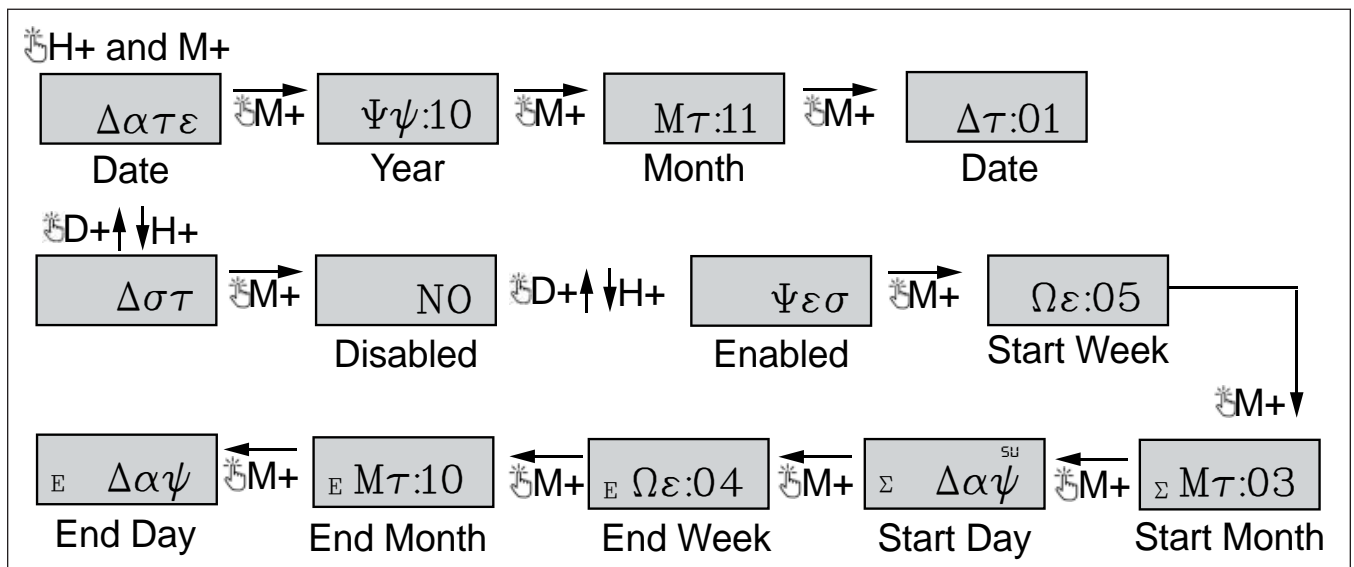



Figure 8.5 — DST and Date Settings

- Use D+ key to increase the parameter value.
 - Use H+ key to decrease the parameter value.
 - Use M+ key to save the current parameter value.
 - Use PR key to escape to previous parameter screen.
- During DST period, d will appear at the bottom left corner of the screen and the day will be updated according to the current date (no need to set the day manually by pressing  and D+ key).

Mode Description

Use the MAN key to toggle between each of the five relay modes. Figure 8.6 describes the function of each mode, and how it appears on the LCD screen.

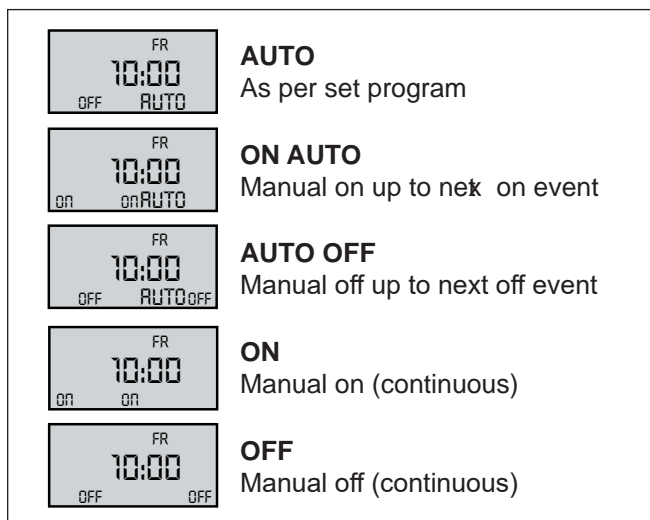



Figure 8.6 — Mode Descriptions

How to Delete the Program

1. To delete a single program, go to the respective program, press H+ until '--' hr comes and press M+ until '--' min comes on LCD. '--:--' displayed on the LCD indicates empty program.
2. Press the RST key to delete/reset all the programs and settings.

Keypad Lock

To lock the keypad, press the  and the PR key simultaneously for three seconds or more. 'bLoC' will appear on the screen, indicating that the keypad has been locked. When the keypad is locked, no parameters can be edited, only the mode can be changed from auto to on auto and auto off by pressing the MAN key. To unlock the keypad, press  and the PR key simultaneously for three or more seconds. ULoC will appear on the screen. The keypad can be locked only in run mode and not in program edit mode.

Frequently Asked Questions

If there is power failure, do I lose all of my programs?

No, the battery has a reserve of approximately six years at operating temperature. In the absence of power, program the device as required. However, during power failure, relay or LED will not operate but the relay status can be observed on the LCD screen.

How to use manual override? When is it applicable?

Press the MAN key to toggle to auto on, auto off, on or off mode (refer to Figure 8.6). Use if an immediate on or off of the relay is required.

Can I select any day of the week as my weekly off?

Yes, when in PR mode, toggle by pressing D+ and the MAN (-) or D+ key respectively for individual holiday selection.

How can I remove all programs and reset RTC?

Press the RST key. All programs will be deleted, RTC will be reset to 00:00 and the default day as Monday.

How do I change the clock format from 12 to 24 hours?

Press  and the MAN key simultaneously to switch the clock format from 12 to 24 hours and vice-versa.

How does the on auto/auto off feature help?

The on auto/auto off feature bypasses the current program and continues with the next program. On auto mode returns to auto mode at the next programmed on time. Auto off mode returns to auto mode at the next programmed off time. The relay to switch on/off can be overridden without affecting the further programs.

Troubleshooting

Refer to Figure 8.7 for information on troubleshooting the timer.

Symptom	Possible Cause	Test Procedure/Corrective Action
The timer is wired incorrectly.	Verify the timer is wired according to the wiring diagram.	Rewire according to the wiring diagram.
The timer programming has not been set.	Verify the programming has been set on the timer.	Program the timer (refer to Programming the Timer).
The backup battery has lost charge.	Verify the timer buttons and screen operate when there is no power to the air dryer.	Replace the backup battery.
The timer has malfunctioned.	All of the above.	Contact Altec AIR technical support.

Figure 8.7 — Troubleshooting the Timer

Zero-Loss Drain

The zero-loss drain allows the air dryer to operate with no purge and no loss of air.

Operating the Drain

Pressurize the Condensate Drain

1. Verify the drain has been installed properly.
2. Make sure the plant system is pressurized.
3. Open the pressure supply valve slowly and check for any leaks within the system. Refer to the depressurization section if any leaks are present.
4. The drain is now ready for use.

Depressurize the Condensate Drain

1. Close the pressure supply valve.
2. Depressurize the drain by repeatedly pressing the test button until no further discharge noise is heard.
3. Turn off the power supply and disconnect the power to the air dryer.
4. Disassemble the drain to repair the leak.

Control Panel and Alarms

Use the control panel on top of the device to monitor the zero-loss drain. This includes two status display LEDs and a malfunction button (refer to Figure 8.8).

- L1 – the green LED indicates power status
- L2 – the red LED indicates alarm status for faults
- P1 – is a multifunction test button

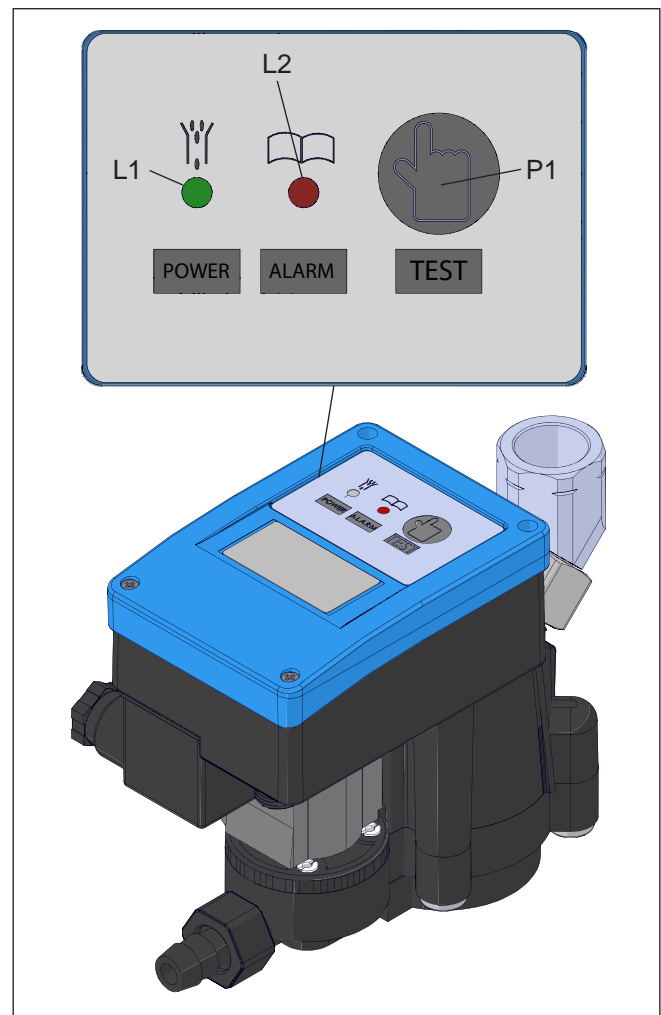

Figure 8.8 — Zero-Loss Drain

Refer to Figure 8.9 for indicator explanations.

Operating Status	Description	L1	L2	P1	Value	Alarm
Supply voltage missing	The condensate drain is disconnected from the power supply. The operating functions are deactivated. An alarm signal is remotely transmitted outside.	–	–	–	–	Red, constant on
Standby, there is no condensate	The supply voltage is applied and the condensate drain is ready to operate. If no condensate is discharged for three hours, the software performs a brief forced discharge. The LED is green, constant on, and the condensate drain activates the same routine until there is a normal discharge that brings the sensor back to the minimum level.	Green, constant on	–	–	Green, off (3 hrs) on (2 sec)	–
Automatic condensate discharge	The maximum level is reached. The valve opens (with a delay of 10 seconds) and the condensate is discharged. The valve closes, as soon as the minimum level is reached.	Green, flashing slowly	–	–	Green, on (max 20 sec)	–
Cleaning routine 1	Even if the valve is opened, the minimum level is not reached within 20 seconds. The condensate drain tries with repeated on/off cycles to unblock the situation probably due to clogging.	–	Red, flashing slowly	–	Green, 30 x on (2 sec) off (2 sec)	–
Cleaning routine 2	The minimum level has not been reached after two minutes of on/off. The condensate drain continues to operate as a timer, continuing with the on/off sequence and continues with alarm states.	–	Red, flashing quickly	–	Green, on (3 sec) off (60 sec)	Red, constant on
Irreversible error	A fault has occurred in the system. Try the reset function. If the problem reoccurs, it requires a technical intervention.	–	Red, constant on	–	Green, on (3 sec) off (60 sec)	Red, constant on
Manual condensate draining	When the test button is pressed, the condensate is discharged manually.	Green, flashing quickly	–	On (max 3 sec)	Green, on (3 sec) max	–
Reset	A reset of the micro's control logic in an alarm state is required. If the problem persists, the alarm and the alarm state will be activated after a short period.	Green LED and red sequence, then constant green	–	On (> 5 sec)	–	–

Figure 8.9 — Control Panel Matrix

Drain Maintenance

The following section provides a recommended preventive maintenance schedule, kit, and instructions to ensure the drain continues to operate at peak performance.

Refer to Operating the Drain in this section for air dryer depressurization prior to performing any maintenance work.

A drain maintenance kit can help to prevent malfunctions and/or critical failures due to the wear and tear of components. Contact your Altec AIR representative for more information.

Refer to Figure 8.10 to identify components.

Visual Inspection and Verification of Correct Operation

1. Inspect the drain for any external damages or leaks.
2. Check the operating state of the drain by reviewing the LED indicators on the control panel (refer to Control Panel and Alarms in this section).
3. Push the test button to verify the operating status of the drain as well as proper condensate discharge of the air dryer.

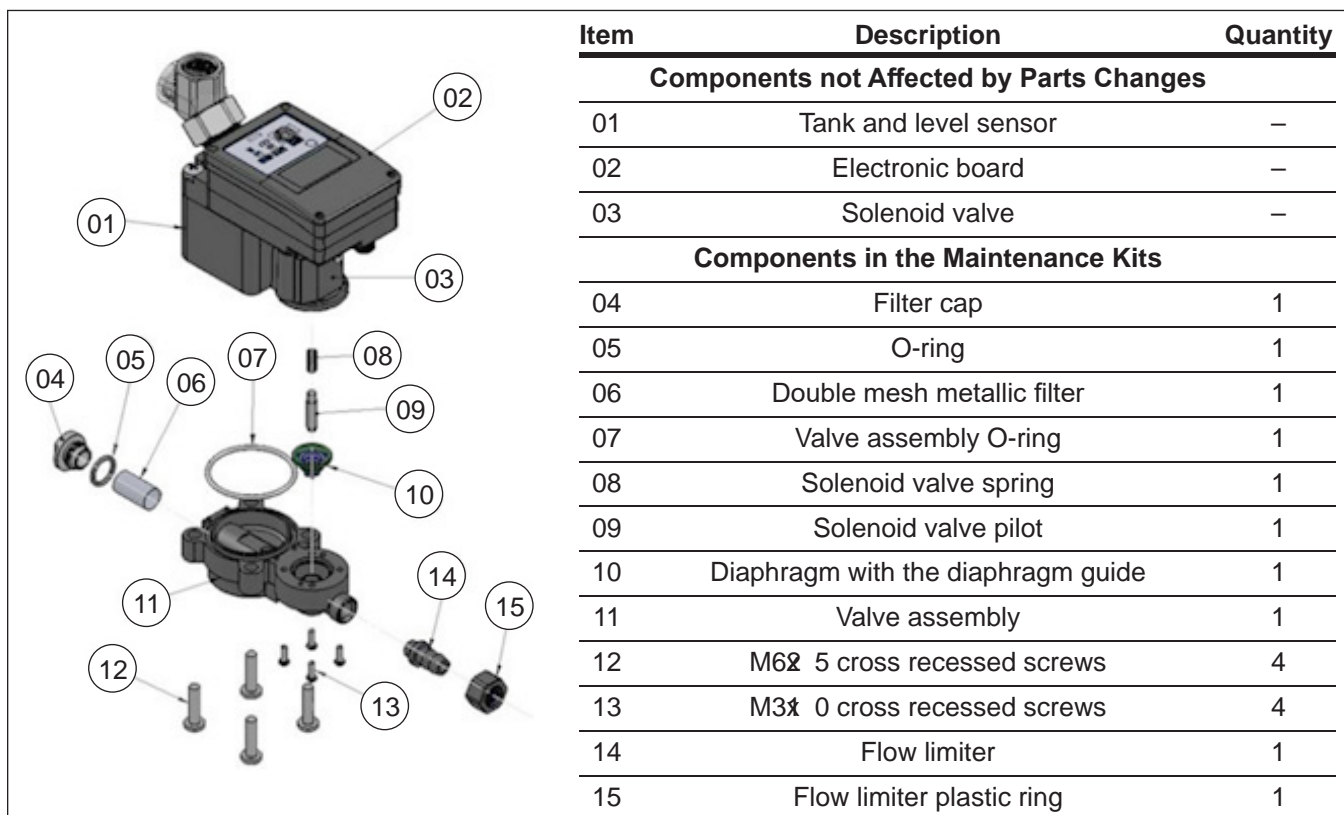

Figure 8.10 — Zero-Loss Drain Exploded View

Cleaning/Replacing the Integrated Filter

1. Unscrew and remove the filter cap.
2. Clean the filter, and replace if necessary.
3. Replace the filter onto the seat of the filter cap.
4. Screw the cap/filter assembly back into the drain, paying close attention not to damage the plastic threading of the valve body.

Repair/Replacement of Wear and Tear Items and Drain Cleaning

1. Open the condensate drain, unscrewing the 4 M6x 5 screws (item 12) and the M3x 0 screws (item 13), and remove the valve assembly (item 11).
2. Unscrew the filter cap (item 04) and extract the integrated filter.
3. Remove the O-ring gasket of the valve assembly (item 07), the O-ring gasket of the filter cap, the solenoid valve spring (item 08), the solenoid valve pilot (item 09), and the diaphragm with the diaphragm guide (item 10).

4. Clean the internal housing of the valve assembly and the aluminum tank.
5. If necessary, clean the level sensor rod and float, being careful not to damage it. Do not bend it, and do not use it as a lever. It contains electronic material. Even moderate mechanical stress can cause irreparable malfunctions.
6. Insert the new O-ring in the filter cap. Place the new filter on the cap and close the valve assembly.
7. Insert the new valve assembly O-ring.
8. Insert the valve components in the following order.
 - a. *The spring and pilot in its spool*
Insert the spring (insert the side without plastic of the pilot inside the spring).
 - b. *The diaphragm with its plastic guide*
Ensure the diaphragm is correctly positioned.
9. Screw the valve assembly onto the condensate drain, tightening the eight screws with the following torque values.

M6 = 8 N•m +2/-1 N•m

M3 = 0,4 N•m ±15%

10. Replace the plastic ring (item 15) with the straight flow limiter (item 14).

11. The container chamber of the electronic board is sealed with a sealing gasket and must not be opened. The required connections can be accessed from the outside by electrical connectors.

Troubleshooting the Drain

Symptom/Error	Possible Cause	Test Procedure/Corrective Action
The drain does not discharge condensate, the condensate drain does not indicate an alarm (status 3 standby).	There is no condensate in the condensate drain. The external shutoff valve between the discharge point and the condensate drain is closed.	Check the supply shutoff valve of the condensate drain.
	The externally installed filter is clogged.	Control the filter that might be installed externally in the condensate supply line.
	The condensate drain has not been installed correctly.	Check the installation (refer to Section 4).
	There may be a siphon effect and/or air bubble upstream of the condensate drain.	Make sure the tube leading to the condensate drain is free.
	The supply voltage is not powering the condensate drain.	Make sure there is electrical power.
		If the previous points have been verified, the condensate drain is operating correctly. Try a manual discharge with the test button.
The condensate drain discharges continuously.	The diaphragm is blocked by dirt, defective, or worn out.	Clean or replace the diaphragm, if necessary, with the maintenance kit (refer to Section 5).
The condensate drain is not discharging and the status 5 of the cleaning routine 1 is active (L2 is slowly flashing).	The level sensor takes more than 20 seconds to discharge the condensate and reach the minimum level.	Clean the integrated filter or substitute if necessary (refer to Section 5).
	The double mesh integrated filter is clogged, dirty, or defective.	Make sure there are no obstructions in the line at the condensate outlet.
	The line at the condensate outlet is clogged.	Try a manual discharge with the test button.
	The amount of condensate is too high.	Make sure the condensate drain is correctly sized for the application.
The condensate drain does not discharge and the status 6 of the cleaning routine 2 (L2 quick flashing) is lit up. The condensate drain is in an alarm situation.	The sensor has not managed to discharge for more than two minutes and reach the minimum level.	Clean integrated filter or replace if necessary (refer to Section 5).
	The double mesh integrated filter is clogged, dirty, or defective. There is a dirt inside the condensate drain and on the plastic sensor rod/float.	Clean the condensate drain internally, remove any dirt from the level sensor rod and float. Warning – do not force, fold, or lever the level sensor rod. Damage may compromise the condensate drain's operations.
	The float is blocked and/or descends with difficulty.	Clean the diaphragm and replace if necessary.
	The diaphragm is clogged or blocked.	Verify that there are no obstructions in the line at the condensate outlet.
	The tube at the condensate outlet is blocked.	Try a manual discharge with a test button.
	There is an excessive quantity of condensate.	Make sure that the condensate drain is correctly sized for the application.
The condensate drain is in an alarm situation, status 7 (L2 is constantly lit).	There is an irreversible error in the condensate drain.	Try resetting the micro logic. If the problem persists, substitute the condensate drain.

Symptom/Error	Possible Cause	Test Procedure/Corrective Action
The manual discharge does not work correctly, status 8 (P1).	Possible clogging or malfunction of the condensate drain solenoid valve.	Substitute the condensate drain, if necessary.
	The coil makes a click sound, but the discharge does not take place. The diaphragm is probably blocked, or the filter is clogged and dirty.	Clean the integrated filter or replace, if necessary (refer to Section 5).
	The condensate drain only discharges air. The diaphragm is dirty or worn out.	Clean the diaphragm and replace, if necessary (refer to Section 5).
	The coil does not make any sound and the condensate drain does not discharge. The solenoid valve is defective.	Substitute the condensate drain, if necessary.

Appendix

Accessories

After identifying the required parts and accessories, contact the Altec AIR Inside Sales/Service department to order.

Accessory	Model	Use with Air Dryer
Floor stands	AFS-1	RAD-0025A, RAD-0055A
		RHT-0010, RHT-0020
	AFS-2	RAD-0075A, RAD-0100A
		RHT-0030, RHT-0040
	AFS-3	RAD-0150A, RAD-0200A
		RHT-0060, RHT-0080
	AFS-4	RAD-0250A, RAD-0300A
		RHT-0100, RHT-0120
Magnetic condenser filters	AFR-1	RAD-0025A, RAD-0055A
		RHT-0010, RHT-0020
	AFR-2	RAD-0075A, RAD-0100A
		RHT-0030, RHT-0040
	AFR-3	RAD-0150A, RAD-0200A
		RHT-0060, RHT-0080
	AFR-4	RAD-0250A, RAD-0300A
		RHT-0100, RHT-0120
	AFR-5	RAD-0400A, RAD-0500A, RAD-0600A
		RAD-0750-A, RAD-1000A, RAD-1250A
Programmable timer ¹	APT-1	RAD-0075A, RAD-0200A
		RHT-0030, RHT-0080
	APT-3	RAD-0250A, RAD-0300A
		RHT-0100, RHT-0120
Zero-loss drain ²	AZD-13 ²	RAD-0250/0300-3
	AZD-14 ²	RAD-0250/0300-4/5
	AZD-23	RAD-0400/0500/0600-3
	AZD-24	RAD-0400/0500/0600-4/5
	AZD-34	RAD-0750/1000/1250-4/5

¹ Aftermarket timer can only be installed on air dryers built after a certain date. Contact Altec AIR to confirm this option is available for the air dryer (refer to AAPN-000086).

² Aftermarket drain can only be installed on RAD-0250/0300 air dryers built after a certain date. Contact Altec AIR to confirm this option is available for the air dryer (refer to AAPN-102).

Wiring Diagrams

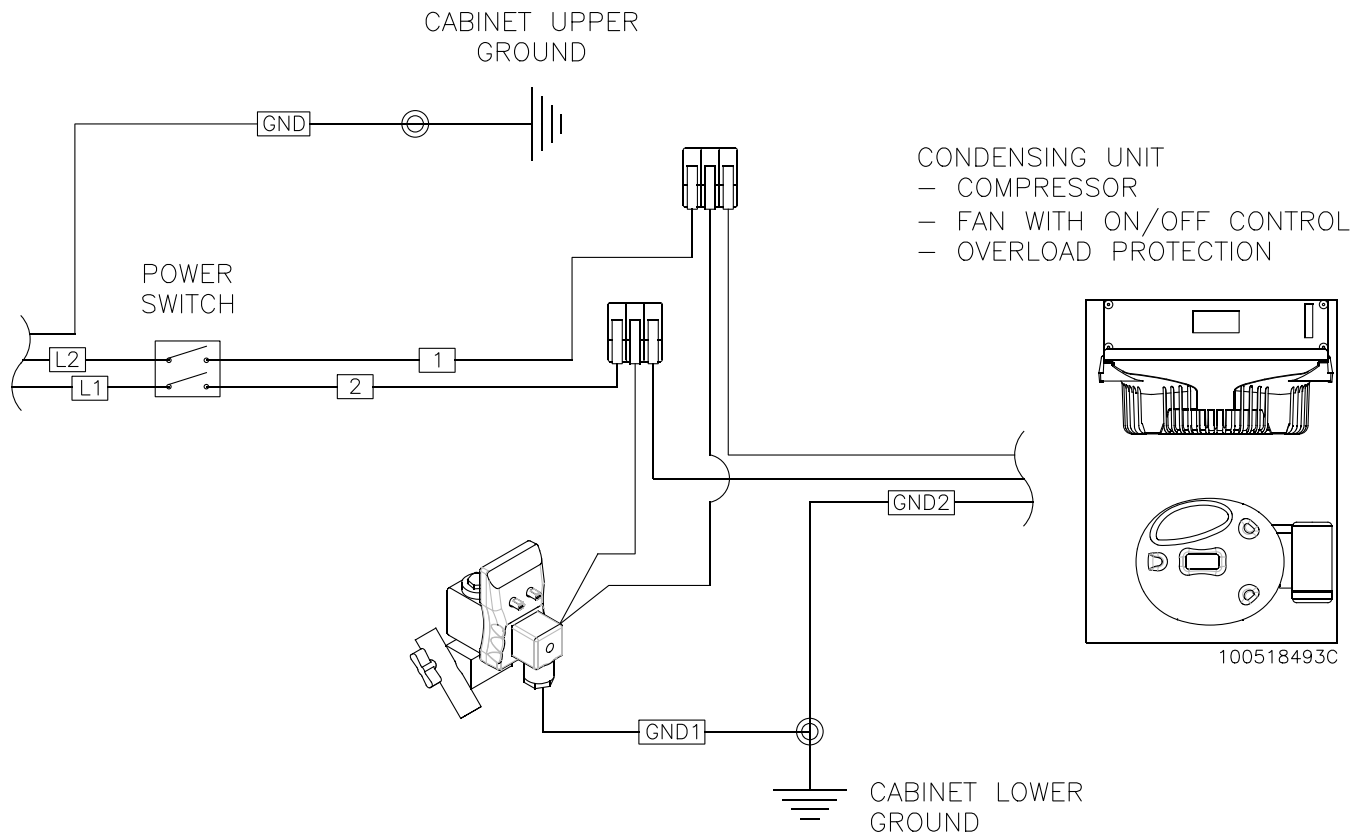

RAD-0025 through RAD-0055 and RHT-0010 through RHT-0020

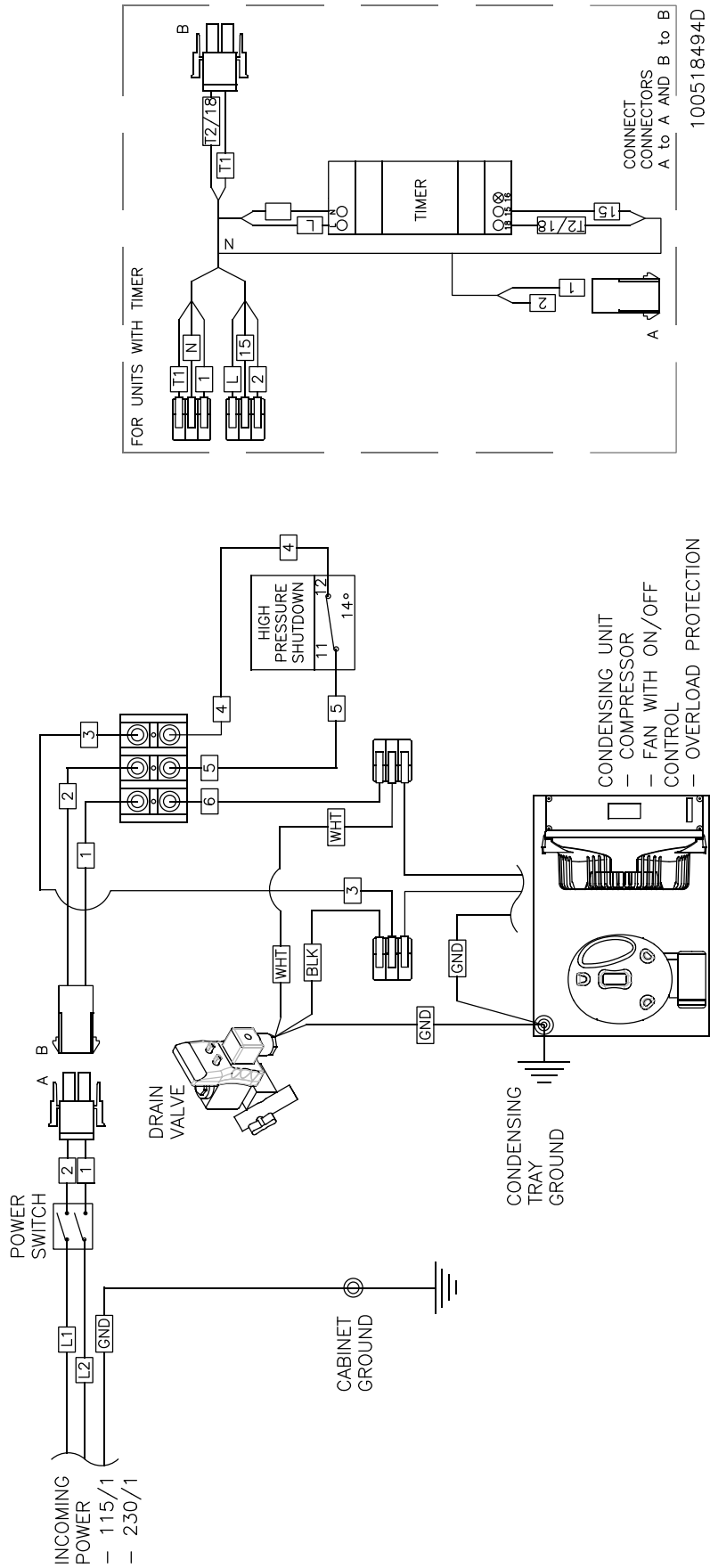

RAD-0075 through RAD-0200 and RHT-0030 through RHT-0080

RAD-0250 through RAD-0300 and RHT-0100 through RHT-0120 (230V)

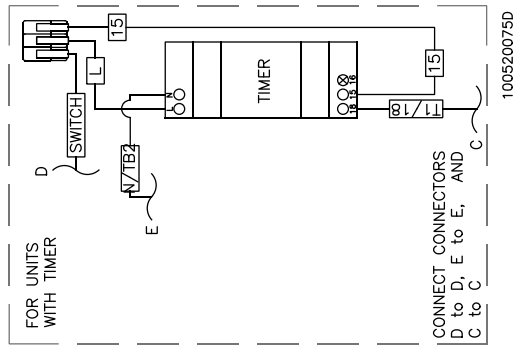
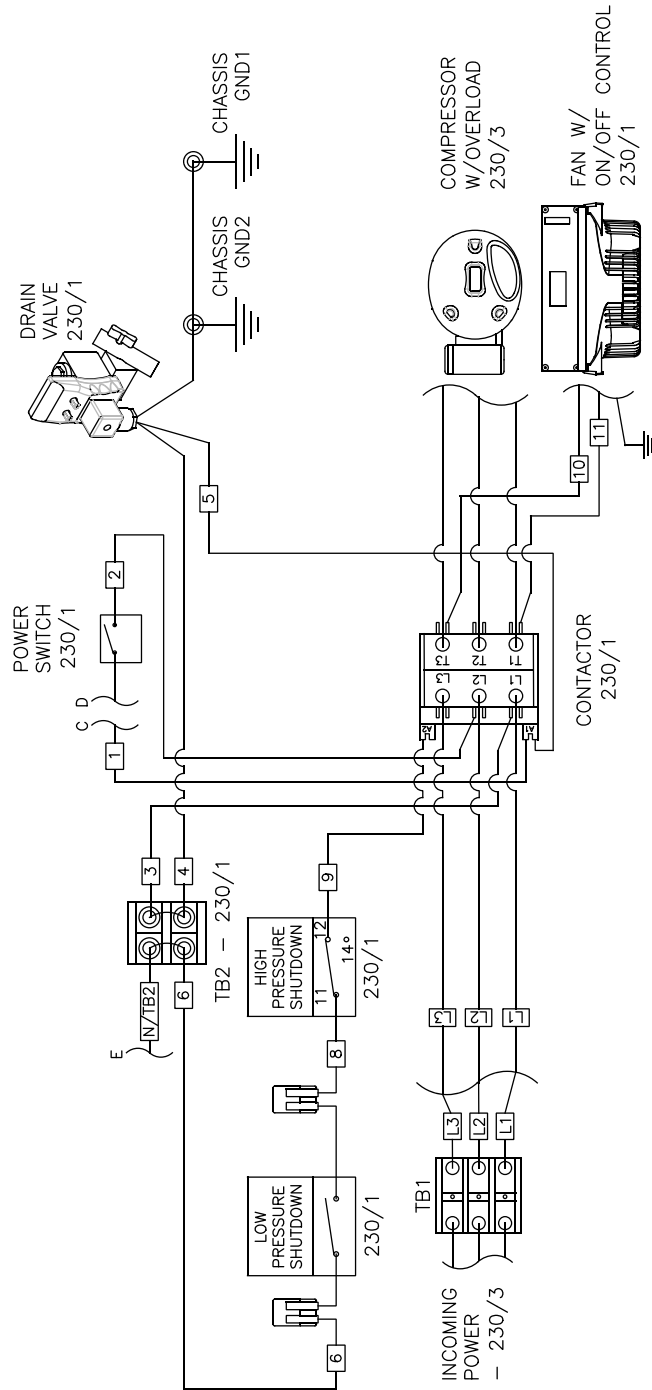

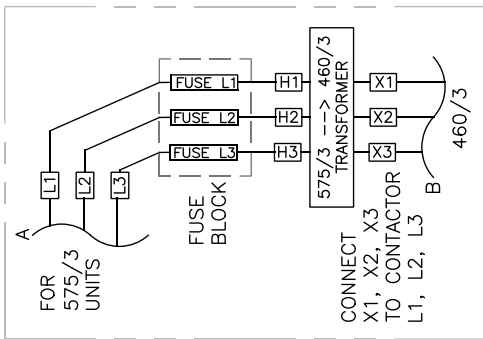
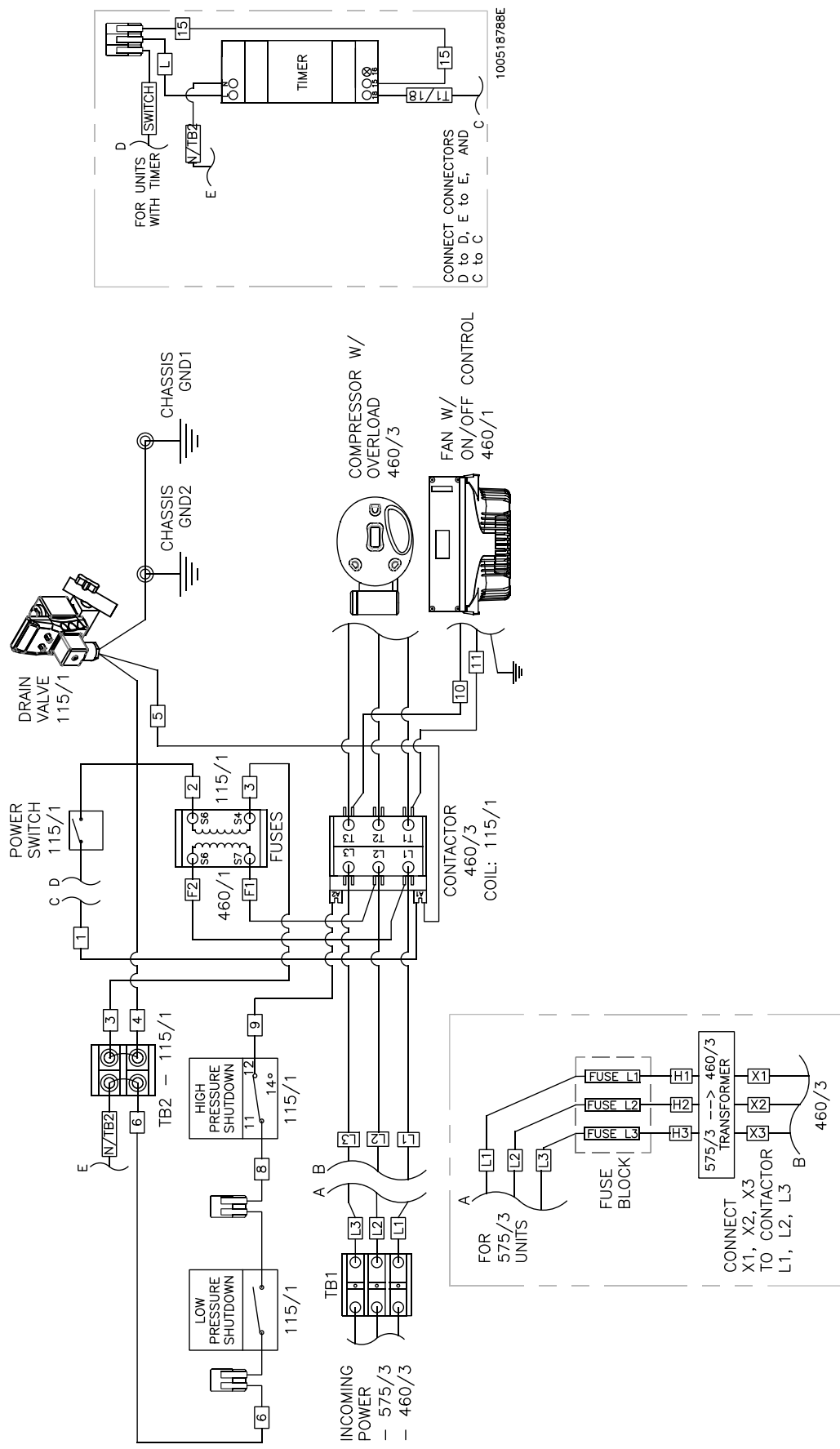

RAD-0250 through RAD-0300 and RHT-0100 through RHT-0120 (460/575V)

INCOMING POWER – 230/3

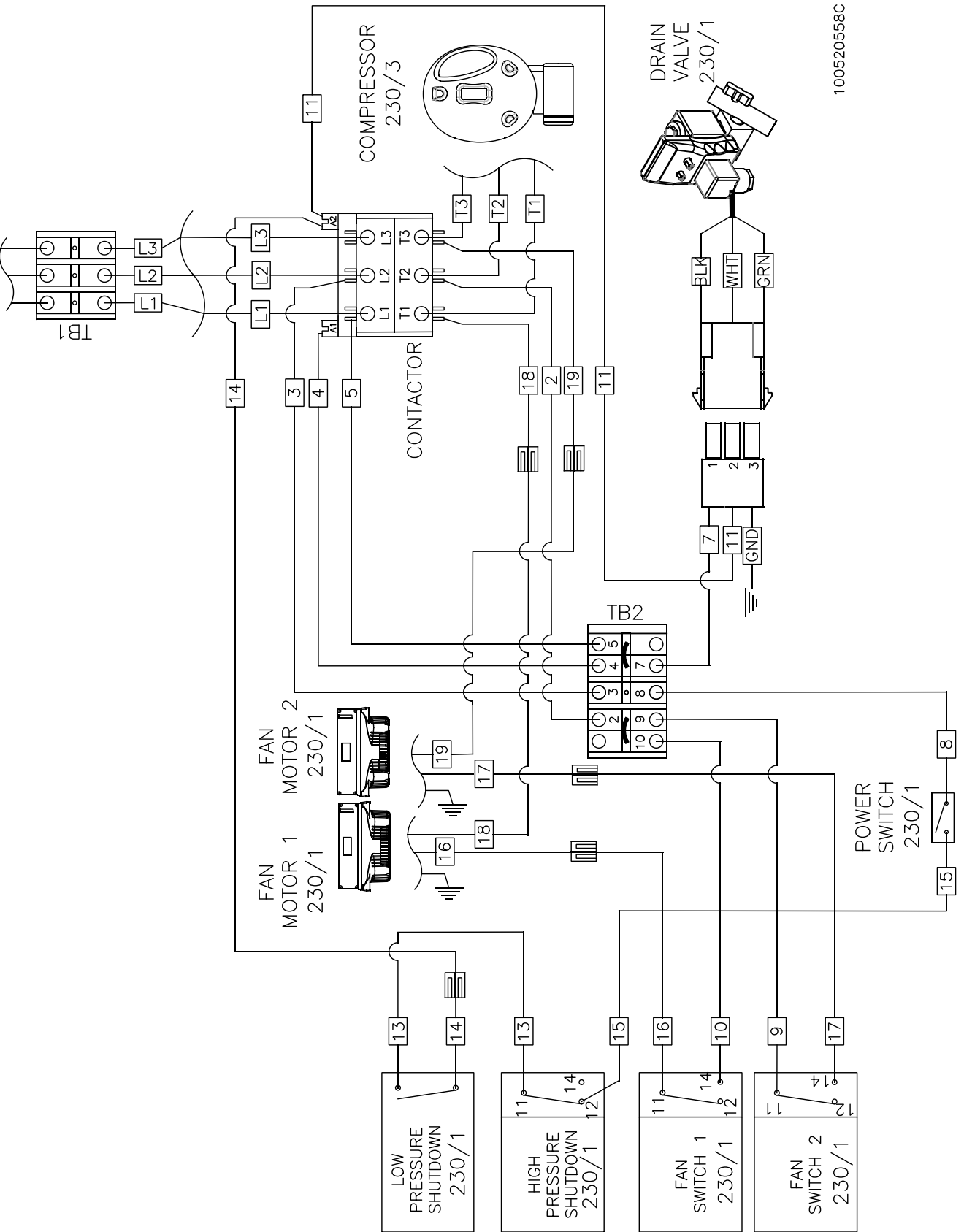

100520558C

RAD-0400 through RAD-0600 (230V)

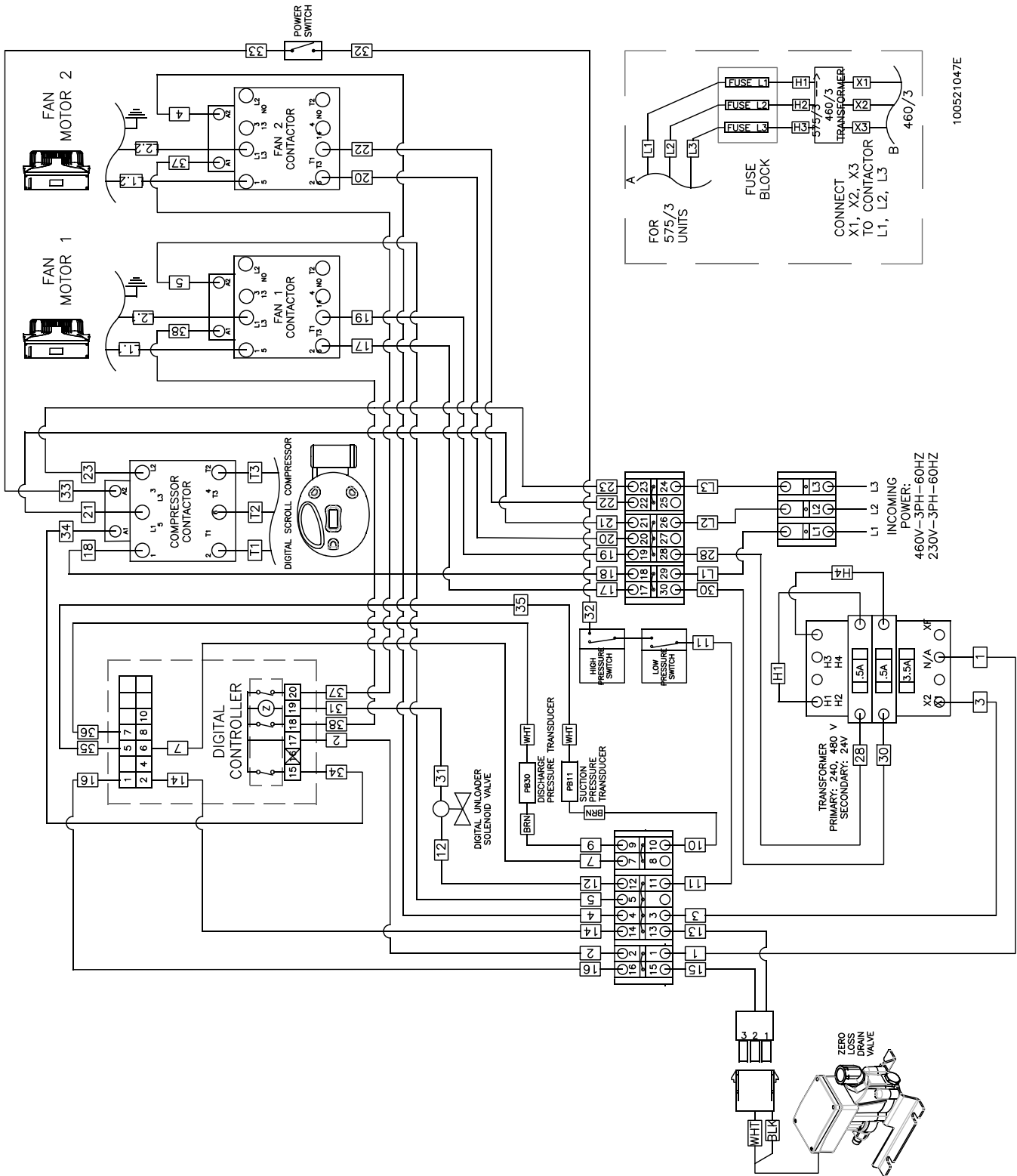

RAD-0400-D through RAD-600-D (230V) and RAD-0400-D through RAD-2000-D (460/575V)

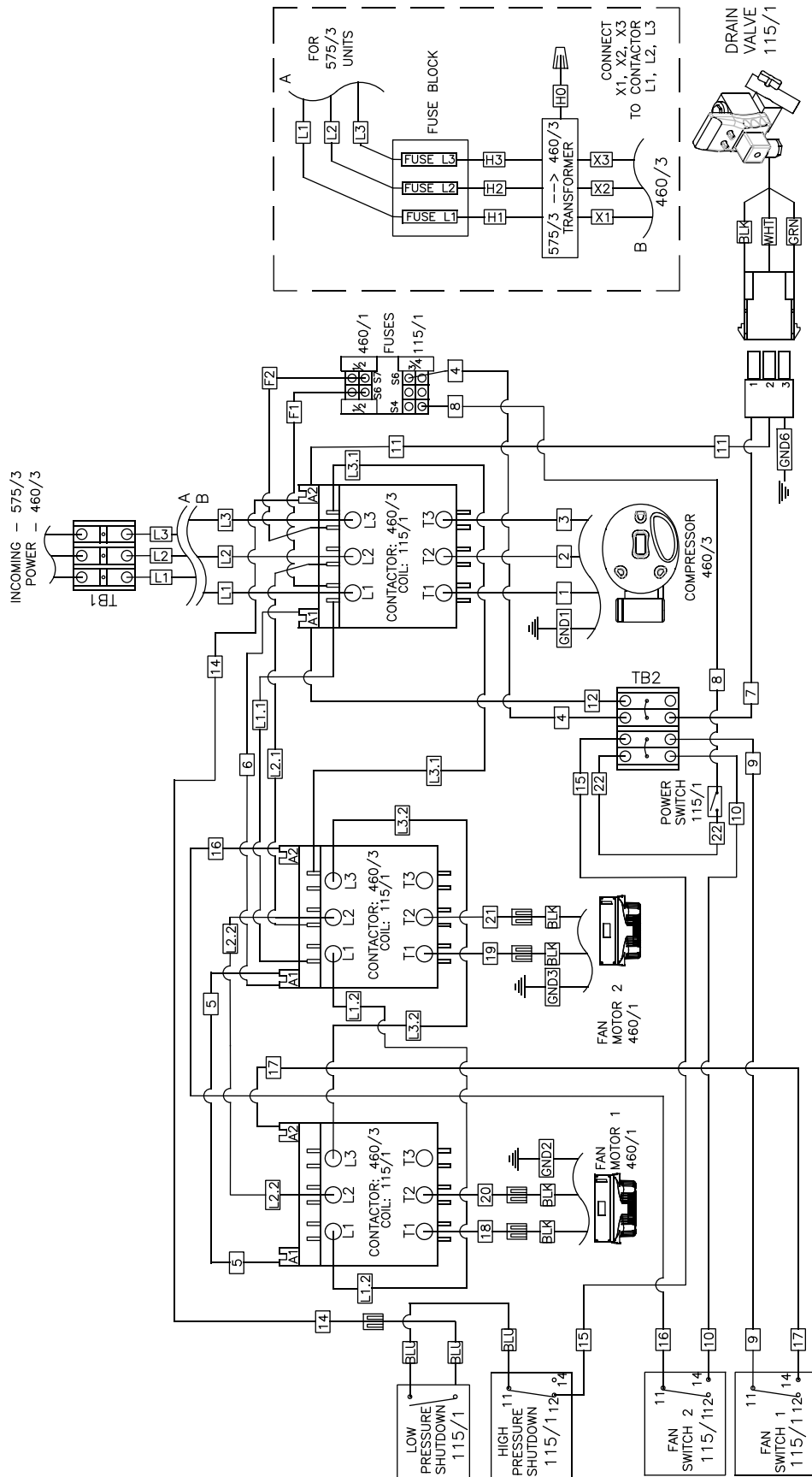

100521162C

RAD-0400 through RAD-2000 (460/575V)
Contact Technical Support for Air Dryers Built Prior to August 1, 2024

Troubleshooting Chart

Symptom	Possible Cause	Test Procedure/Corrective Action
Excessive pressure loss in the system.	Bypass valve is not completely open.	Open bypass valve completely.
	Install pipe diameter is too small.	Replace with pipe with larger diameter.
	Install piping system has too many tie ins.	Redesign piping system.
	Inlet flow exceeds maximum capacity.	Check inlet flow versus rated capacity.
	Leaks in the piping system.	Fix leaks in the piping system.
	Freezing of moisture in evaporator is restricting inlet air flow.	If refrigerant suction pressure is out of standard operating range, adjust the hot gas bypass valve. If the valve won't adjust it can indicate a refrigerant leak or low charge. To verify check superheat and subcool.
Water is getting downstream of the dryer.	In line filter element is clogged.	Replace filter element.
	Bypass valve is not completely closed off.	Verify bypass valve is closed completely.
	Suction pressure is not in operating range.	If refrigerant suction pressure is out of standard operating range, adjust the hot gas bypass valve. If the valve will not adjust it can indicate a refrigerant leak or low charge. To verify, check superheat and subcool.
	Ambient temperature surrounding downstream piping is below the dryer's dew point.	Insulate piping downstream of dryer.
	Dryer is overloaded resulting in high dew point.	Verify initial design conditions for dryer operation have not changed (inlet and ambient temperature, inlet pressure and flow).
	Auto drain is plugged or not working.	"Depressurize the dryer and clean or replace the drain strainer."
	Dryer is too small for the inlet flow.	Check the flow capacity of the dryer and reduce flow or replace dryer.
The evaporator/condenser pressure is too high or low.	No pre-filter in the system.	Install pre-filter.
	Inlet air temp combined with ambient air temp is too high.	Verify heat capacity of the dryer, check after cooler on the compressor and rectify.
	Air cooled condenser is clogged with dirt and debris.	Clean condenser per required maintenance.
	Thermostatic expansion valve is defective.	Troubleshoot the thermostatic expansion valve and replace if necessary.
	Refrigerant leak in the system.	Locate the leak. Repair and recharge the system according to the data label refrigerant charge amount.
	Condenser fan is not running.	Replace the fan.
	Hot gas bypass valve needs adjusting.	If refrigerant suction pressure is out of standard operating range, adjust the hot gas bypass valve.

Symptom	Possible Cause	Test Procedure/Corrective Action
Power is on to the dryer but it will not start.	No power going to the dryer.	Verify power is present.
	Incorrect voltage going to the dryer.	Verify correct voltage is going to the dryer.
	Contactors are damaged.	Test the contactors and replace if necessary.
	On/off switch is damaged.	Test the on/off switch and replace if necessary.
	Capacitor is damaged.	Test the capacitor and replace if necessary.
	Overload is damaged.	Test the overload and replace if necessary.
	Start relay is damaged.	Test the start relay and replace if necessary.
	Compressor is damaged.	Test the compressor for shorted legs or ground. Replace if necessary.
	High pressure switch is open.	Verify the high pressure switch is set to correct limit [300 or 400 psi (20.68 or 27.58 bar)] depending on refrigerant. Verify if the cause of the open state is a damaged switch or legitimate by verifying discharge pressure with manifold readings or on the discharge gauge (if equipped). Replace the high pressure switch if it is found to be triggering from readings lower than setpoint.
	Low pressure switch is open.	Replace the low pressure switch.
Heat exchanger is freezing.	Fuse on the transformer is damaged.	Test the fuse and replace if necessary.
	Low ambient temperature.	Low ambient room temperatures may cause freezing. Remedy room conditions. Smaller dryers that do not have a fan cycling switch in low ambient temperatures can also encounter this issue.
	Seasonal ambient conditions.	Hot gas bypass valve may need to be adjusted between hot and cold season changes on dryers without a thermostatic expansion valve.
	Low charge or refrigerant leak.	Check system health of superheat and subcool.