

Altec | AIR

MHR SERIES HEATLESS REGENERATIVE AIR DRYERS



TABLE OF CONTENTS

- ⇒ 3 - INTRODUCTION
- ⇒ 3 - INTRODUCTION MHR HEATLESS REGENERATIVE DRYING
- ⇒ 4 - APPLYING YOUR DRYER
- ⇒ 4 - DRYER SIZING AND CORRECTION FACTORS
- ⇒ 5 - INSTALLATION
- ⇒ 6 - INSTALLATION GUIDE
- ⇒ 7 - PRINCIPLE OF OPERATION
- ⇒ 7 - START UP
- ⇒ 8 - DRYER INDICATING LIGHTS
- ⇒ 9 - MAINTENANCE
- ⇒ 10 - PNEUMATIC SCHEMATIC
- ⇒ 11 - ELECTRICAL SCHEMATIC
- ⇒ 12 - ECONO-PURGE CONTROLLER
- ⇒ 13/14 - TROUBLESHOOTING
- ⇒ 15 - CONTACT INFORMATION

IMPORTANT: READ THIS MANUAL CAREFULLY. IT CONTAINS INFORMATION ABOUT SAFETY AND THE SAFETY OF OTHERS. ALSO BECOME FAMILIAR WITH THE PROPER INSTALLATION AND CONTROLS OF THE AIR DRYER BEFORE OPERATING. ONLY QUALIFIED, TRAINED AND LICENSED PERSONAL SHOULD SERVICE OR OPERATE THIS EQUIPMENT.

CAUTION: THIS MACHINE CONTAINS HIGH PRESSURE GAS AND ELECTICITY

READ CAREFULLY BEFORE ATTEMPTING TO INSTALL, OPERATE OR MAINTAIN YOUR DRYER. PROTECT YOURSELF AND OTHERS BY OBSERVING ALL SAFETY INFORMATION. FAILURE TO DO SO COULD RESULT IN PERSONAL INJURY AND/OR PROPERTY DAMAGE. KEEP OWNER'S MANUAL FOR FUTURE REFERENCE.

INTRODUCTION

Thank you for selecting an MHR series regenerative air dryer from Altec AIR . The regenerative air dryer is specifically designed and manufactured for drying and purifying compressed air generated by an air compressor.

Please read this instruction manual carefully before using the air dryer.

Please pay attention to the precautions in transportation, installation and operation that are listed in this manual.

Please use the dryer according to our application guide and be sure to perform the proper preventative maintenance as recommended in this manual. Failure to perform the preventative maintenance will void the air dryer warranty.

Direct any questions not covered in this manual to your distributor or call Altec AIR . @ 1-800- 521-5351. Before calling with questions always have the air dryer model #, serial # and pressure gauge readings.

Service and maintenance can be obtained from your distributor. If you do not know your distributor please contact the factory. Authorization must be obtained from Altec AIR before any parts or dryers are returned to the factory. Altec AIR will not be responsible for anything returned without authorization.

ALTEC AIR MHR SERIES REGENERATIVE AIR DRYERS ARE SHIPPED AS COMPLETELY ASSEMBLED PACK-AGES, ALL SIZES UP TO MHR500 AND ABOVE ARE FILLED WITH DESICCANT READY TO INSTALL. DESICCANT IS SHIPPED LOOSE ON MODELS MHR800 AND ABOVE. THE TOWERS MUST BE FILLED WITH DESICCANT AT THE JOB SITE ON MODELS MHR800 AND ABOVE. VISUALLY CHECK THE DRYER FOR DAMAGE THAT MAY HAVE OCCURRED IN TRANSIT. IF THERE IS EVIDENCE OF DAMAGE, IMMEDIATELY ENTER A CLAIM WITH THE CARRIER, AND NOTIFY YOUR ARROW REPRESENTATIVE.

INTRODUCTION MHR HEATLESS REGENERATIVE DRYING

Twin tower regenerative air dryers are the dryers of choice when traditional refrigerated dryers do not provide sufficient air quality required for today's applications. Altec AIR MHR series of heatless twin tower regenerative dryers normally produce -40°F and can optionally be as low as -100°F dew points.

The dryer utilizes activated alumina for efficient drying of compressed air and will operate under extreme environmental conditions. Activated alumina is aluminum oxide that is highly porous and exhibits tremendous surface area (350 sq. meters/gram). Activated alumina is resistant to thermal shock and abrasion. It has a smooth, uniform ball size that prevents channeling of the air flow, which maintains low bed velocities. This maintains air contact time for efficient moisture removal and minimal pressure drop. The MHR's printed circuit board dryer controls are housed in a NEMA 4X rated enclosure and provide control of pneumatically piloted valves chosen for long life and high air flow.

ADDITIONAL SPECIFICATIONS

Specifications and dimensions are subject to change without notice.

Standard Design Conditions: **100°F inlet temperature, 100 psig and 100°F ambient temperature.**

For other than standard design conditions or capacities up to 12,000 scfm, contact Altec AIR for details.

Maximum pressure drop of **2 PSIG**

Maximum Working Pressure: **150 PSIG**

Minimum Working Pressure: **75 PSIG**

Maximum Inlet Temperature: **120°F**

Minimum Inlet Temperature: **32°F**

Standard Pressure Dew Point: **-40°F**

Electrical Construction: **NEMA 4X**

Standard Voltage: **120V/1PH/60HZ**

AMPS: **0.5**

APPLYING YOUR AIR DRYER

TO ACHIEVE THE BEST DRYER PERFORMANCE, YOU SHOULD CAREFULLY CHECK THAT THE DESIGN AND INSTALLATION REQUIREMENTS OUTLINED BELOW ARE SATISFIED.

(1) Standard operating pressure of your ALTEC AIR Dryer can range from 75 minimum to 150 maximum PSIG. Check dryer label to verify maximum service pressure. Air available for your air usage will vary with operating pressure.

(2) The dryer should not be installed where compressed air and/or ambient temperature exceeds 120°F or drops below 32°F. Locate dryer to avoid extremes of heat and cold from other conditions. Best results occur when dryer is located as close to point of use as practical. Where applicable, dryer towers should be insulated to reduce heat loss. Avoid locating dryer outside or where it is exposed to the elements.

Altec AIR dryers are sized according to air flow not pipe size. The dryer requires 10% to 15% of inlet airflow (SCFM) for regeneration. The difference between the inlet and outlet flow is the amount of purge air required. This air is purged to atmosphere and is not available for use downstream. certain air supply to dryer meets your air demand plus purge air requirements.

DRYER SIZING AND CORRECTION FACTORS

SEE DRYER SIZING CORRECTION FACTORS TO PROPERLY SIZE DRYER BASED ON YOUR ACTUAL OPERERATING CONDITIONS:

1. INLET AIR FLOW
2. INLET AIR PRESSURE
3. INLET AIR TEMPERATURE

OPERATING PRESSURE PSIG	% OF PURGE LOSS	INLET PRESSURE PSIG	CAPACITY MULTIPLIER	INLET TEMP DEG. F	CAPACITY MULTIPLIER
250	8.40%	250	1.85	120	0.67
200	9.10%	200	1.70	110	0.76
175	9.90%	175	1.55	100	1.00
150	11.20%	150	1.35	90	1.13
140	11.60%	140	1.30	80	1.14
130	12.00%	130	1.25		
120	12.70%	120	1.17		
110	13.50%	110	1.09		
100	14.60%	100	1.00		
90	15.90%	90	0.90		
80	17.50%	80	0.80		
70	19.70%	70	0.70		
60	22.50%	60	0.60		

EXAMPLE

To calculate the capacity of a MHR100 @ 120 psig and 90 F inlet temperature:
 $100 \text{ scfm (inlet)} \times 1.17 \text{ (pressure)} \times 1.125 \text{ (temperature)} = 132 \text{ scfm (actual inlet capacity)}$

Actual Capacity of a MHR100 @ 120 psig and 90F = 132 scfm @ -40F/C Pressure Dew Point*

*Contact Altec AIR or your local distributor for how to adjust your MHR for -100F/-73C Pressure Dew Point Operation.

INSTALLATION

DRYER LOCATION / VENTILATION

Install dryer only in a well-ventilated, clean, dry area and keep at least 3 feet between the dryer, other equipment and the walls.

AMBIENT TEMPERATURES

Suitable ambient temperature for the refrigerant dryer is a MIN of 32°F to a Max of 110°F. The performance of the dryer will be significantly decreased when the air dryer is subject to temperatures higher than 110°F.

INLET & OUTLET CONNECTIONS

Do not mix the air inlet and outlet air flow. INLET port is located at the bottom of the MHR dryer. The OUTLET port is located at the top of the dryer. Pipe diameter should be sized according to air flow requirements. It is recommended that a vibration absorber be installed on the dryer inlet and outlet to eliminate vibration from the compressor.

FILTRATION, BYPASS VALVES, & CONDENSATE DRAINS

Appropriate pre and post filtration should be installed to protect the air dryer as well as the compressed air system.

IMPORTANT: PRE-FILTERS AND AFTER-FILTERS MUST BE INSTALLED BEFORE AND AFTER DRYER.

Compressed air entering the dryer must be cooled to at least 120°F.

Install **Pre-Filters** to "Inlet Air" connection on the bottom piping assembly. Pre-Filters protect desiccant beds from contamination by oil, entrained water, pipe scale, etc., thereby extending dryer desiccant life.

Install **After-Filter** to "Outlet Air" connection on the top piping assembly. After-filters, located after the dryer, help eliminate the possibility of desiccant dusting and carry over into the air system.

It is recommended to install a **check valve** after the dryer to prevent plant air from escaping out of the dryer purge valve during periods of low or no plant air demand.

Isolation or 3-valve bypass should be installed on the air dryer outlet and inlet ports to allow for bypassing, depressurizing, proper maintenance, and servicing of the air dryer.

For all filters, water separators, tanks, etc - the proper condensate drains must be used to remove moisture from the system. The user must run a drain line to an environmentally approved condensate collection/disposal system.

ELECTRICAL INSTALLATION

The dryer Data Label lists the electrical power requirements for the air dryer. The user must confirm that the line voltage matches the voltage listed on the data label. (Warning – Operating the air dryer with improper line voltage will void the warranty). Provide the proper size wire, disconnect switches and fuses in accordance with applicable codes. Field wiring must comply with local and national fire safety and electrical codes. Standard dryer's enclosures and controls are designed to meet NEMA 4X electrical standards.

Connect power leads as indicated in the electrical schematic. Ground the frame properly.

MAXIMUM WORKING PRESSURE - 150 PSIG.

BREATHING AIR APPLICATIONS

This dryer has not been tested for breathing air applications. The owner is advised to do its own testing and use for breathing air applications at own's risk.

INSTALLATION GUIDE

INSTALLATION GUIDE A

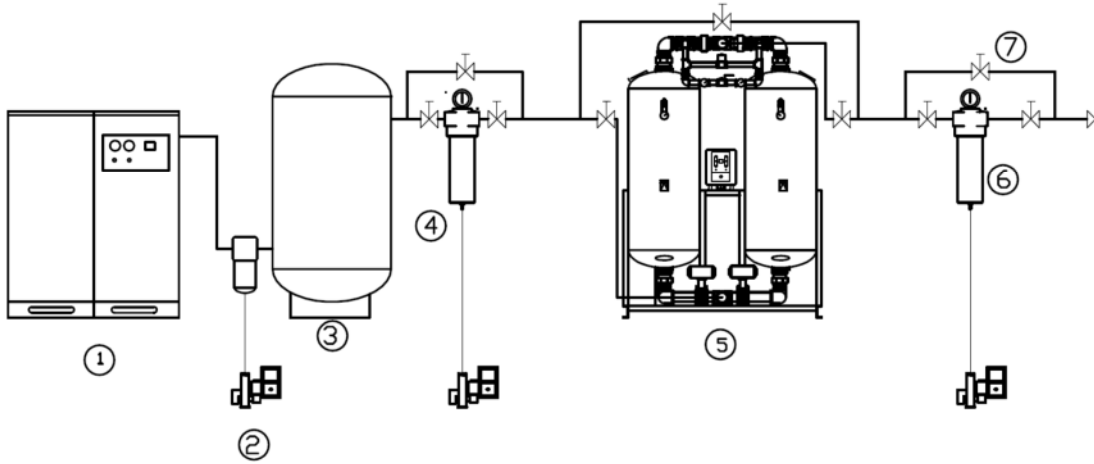

INSTALLATION GUIDE B

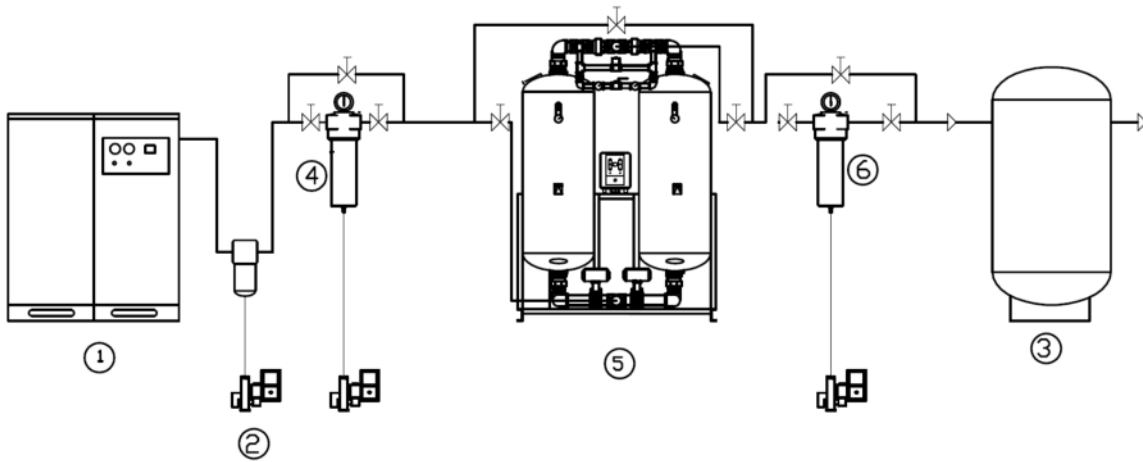

- 1 – AIR COMPRESSOR
- 2 – ADF SERIES DRAIN VALVE
- 3 – RECEIVER TANK
- 4 – AC SERIES PRE-FILTER

- 5 – MHR SERIES AIR DRYER
- 6 – AP SERIES AFTER-FILTER
- 7 – 3 VALVE BYPASS

INSTALLATION A: Recommended for systems that consume **less than or equal to** the maximum capacity of the air compressor.

INSTALLATION B: Recommended for systems that may at times **consume more than** the maximum capacity of the air compressor.

PRINCIPLE OF OPERATION

MHR Series heatless regenerative air dryers utilize the pressure swing principle of operation.

Compressed air saturated with water vapor passes through the inlet valve and flows upward through the desiccant in tower "A". Tower "A" is said to be "ON-LINE". The activated alumina desiccant adsorbs the water vapor in the compressed air and the pressure dew point is lowered to a minimum of -40°F. The dried air then passes through a check valve assembly to the outlet piping and then to the factory tools or equipment.

While the air is being dried in tower "A" the desiccant in tower "B" that adsorbed moisture in the previous cycle is simultaneously regenerated. Tower "B" is "OFF-LINE". At the start of the regeneration cycle, tower "B" is depressurized from the operating pressure to atmospheric pressure with a downward air flow and passes through the purge valve and out the purge muffler. Regeneration continues with a portion of the dry air from tower "A" passing through an orifice assembly and downward through tower "B" out to atmosphere.

This process takes about ten minutes to complete, with the drying cycle using about five minutes to provide the desired dew point. The regeneration cycle takes approximately 45 seconds less to allow for re-pressurization before switchover. The complete operation therefore consists of two cycles, one for drying and the other for regeneration. Required purge air is generally 15% of rated flow. As pressure is a direct function of purge air, the higher the pressure, the lower the purge.

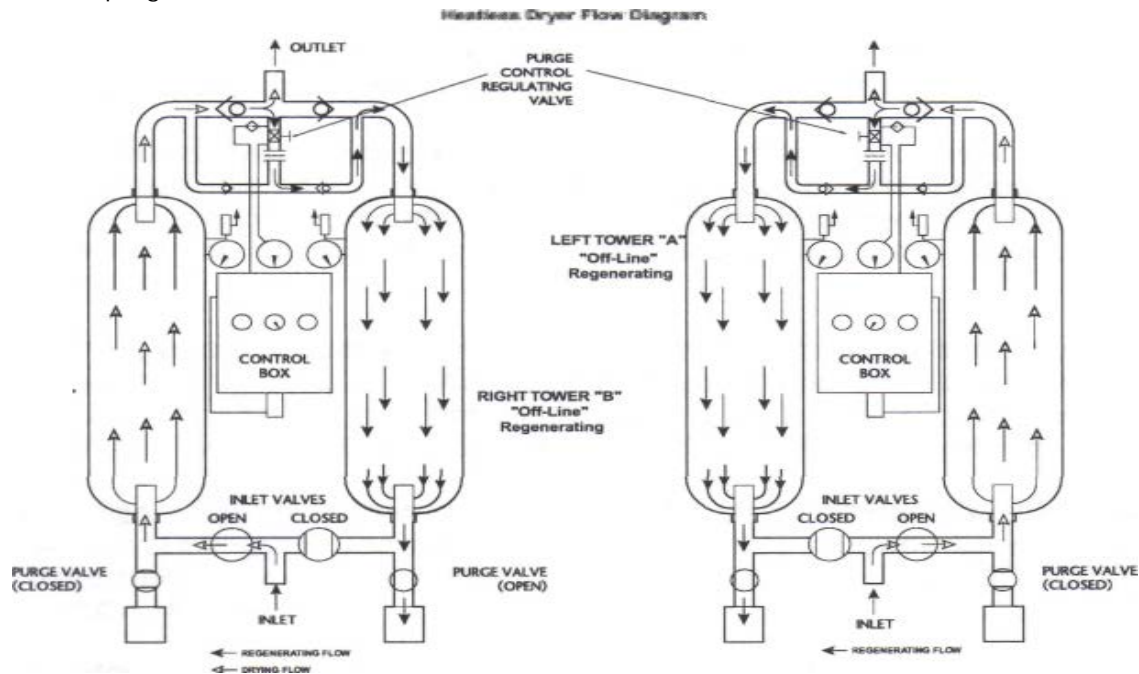

START UP

1. SLOWLY PRESSURIZE THE DRYER
2. Energize electrical circuit by simply pressing the power ON/OFF button.
3. The Power ON LED will be illuminated when the dryer is in operation. When the electrical circuit has been energized, the control circuit board will start to operate and automatically initiate dryer operation. The timer is factory set, so that no field adjustment is necessary.
4. Adjust Purge Adjustment Valve so that the center Purge Pressure Gauge reads appropriate pressure:

MODEL	PURGE PRESSURE	MODEL	PURGE PRESSURE
MHR75	20 PSIG	MHR520	35 PSIG
MHR100	20 PSIG	MHR620	50 PSIG
MHR125	40 PSIG	MHR800	40 PSIG
MHR150	40 PSIG	MHR1000	45 PSIG
MHR200	20 PSIG	MHR1200	50 PSIG
MHR250	30 PSIG	MHR1600	50 PSIG
MHR350	45 PSIG	MHR2000	40 PSIG

DRYER INDICATING LIGHTS

Tower Drying – The Tower Drying LED will be illuminated indicating which tower is online and in the drying mode.

Tower Regenerating – The Tower Regenerating LED will be illuminated indicating which tower is off line and in the Regenerating mode.

Repressurizing – The Tower Repressurizing LED will be illuminated indicating which tower is online and in the drying mode.

Failure to Shift - The Failure to Shift LED will be illuminated when a dryer shift failure has occurred. The shift failure was due to a Failure to Depressurize or Failure to Repressurize. Observe dryer operation to determine which failure caused the Failure to Shift and refer to Troubleshooting Guide.

Power ON – Illuminated when the switch is in the ON position.

MHR CONTROL PANEL

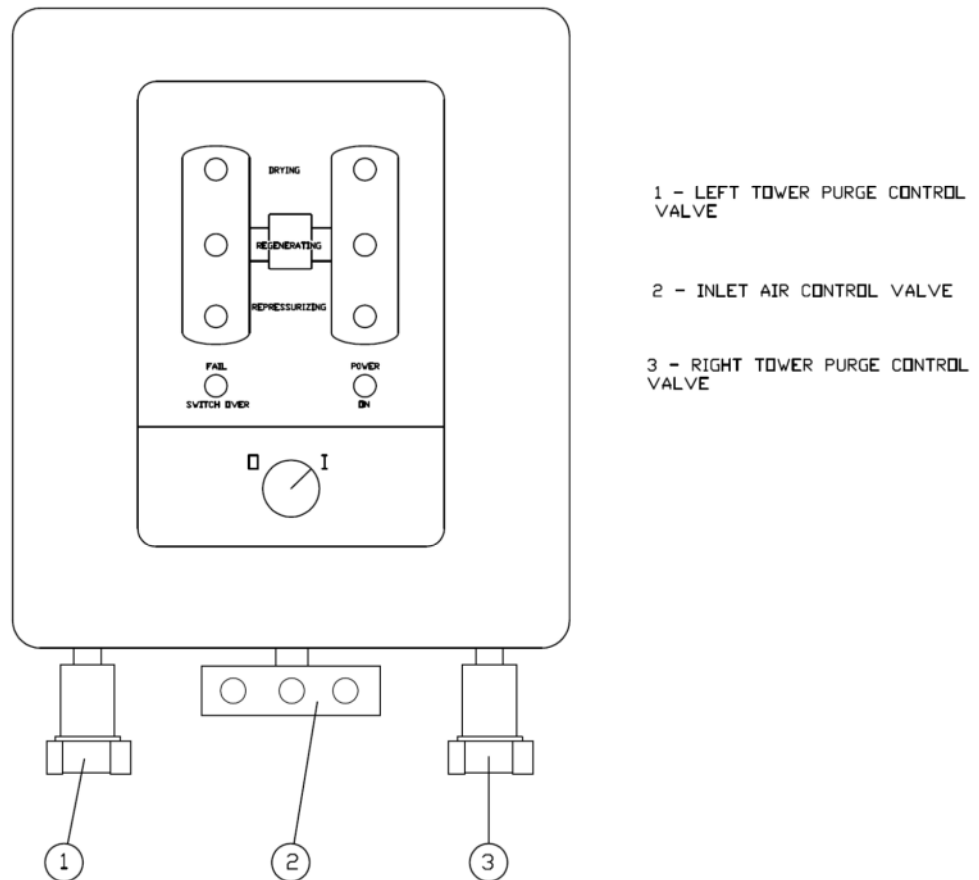

MAINTENANCE

Purge Muffler

At high pressures a clogged muffler could result in a high backpressure and could result in mechanical failure or personal injury. For this reason the purge muffler must be periodically checked for any restrictive debris. If pressure is observed on the offline tower replace muffler immediately.

Purge Valves

Should either of the normally closed purge valves fail to operate check the following:

1. Check air signal to valve.
2. If air signal is present; disassemble, clean and replace diaphragm and seals.
3. If no air signal is present; see solenoid valve information in Maintenance Section.

Inlet Valves

Should either of the normally open inlet valves fail to operate check the following:

1. Check air signal to valve.
2. If air signal is present; disassemble, clean and replace diaphragm and seals.
3. If no air signal is present; see solenoid valve information in Maintenance Section.

Outlet and Purge Check Valves

NOTE: Signs of a faulty outlet and/or purge check valve include;

- Failure to Depressurize Alarm
- System air is being drained and compressor is running at below normal efficiency.
- Periodically check the outlet and purge check valves for an absolute seal. Procedure:
 - * Close purge adjustment valve. Verify offline tower pressure is 0 PSIG.
 - * Check offline purge muffler for airflow. No airflow should be present.
 - * If no airflow is present, the outlet and purge check valve have a positive seal. Repeat procedure next cycle to check opposite outlet and purge check valves
 - * If airflow is present, the outlet and/or purge check valves do not have a positive seal. Clean and/or replace corresponding check valves. See air flow diagram for corresponding check valves.

Pilot Air-Filter (Located at Outlet)

For maximum filtration efficiency, service the element 2x per year.

PREVENTATIVE MAINTENANCE SCHEDULE

<p><u>Daily</u></p> <ul style="list-style-type: none"> • Check and record inlet pressure, temperature and flow. • Verify that it is within specifications. • Check tower pressure gauge readings within operating tolerance. • Check tower pressure gauges for proper dryer cycling. • Verify that pressure in purging tower is 5 PSIG or less. • Verify that prefilters and off-line differential pressure is within operating limits. 	<p><u>Semi-Annually</u></p> <ul style="list-style-type: none"> • Check outlet dew point. • Blow down relief valves.
<p><u>Monthly</u></p> <ul style="list-style-type: none"> • Check your operating conditions: inlet flow, inlet pressure, and inlet temperature. • Check prefilters and after filters. • Check dryer cycle and sequence of operations, (i.e. drying and regenerating). 	<p><u>Annually</u></p> <ul style="list-style-type: none"> • Check desiccant and replace if necessary. • Inspect and clean pilot operated valves and replace packing as necessary. • Inspect and clean solenoid valves, check valves and purge lines. • Test electrical components, replace as necessary.
<p><u>Quarterly (3 Months)</u></p> <ul style="list-style-type: none"> • Check pilot air filter element and clean. • Replace prefilter and afterfilter elements. 	<p><u>3-Years</u></p> <ul style="list-style-type: none"> • Replace desiccant (if necessary)

PNEUMATIC CONTROLS

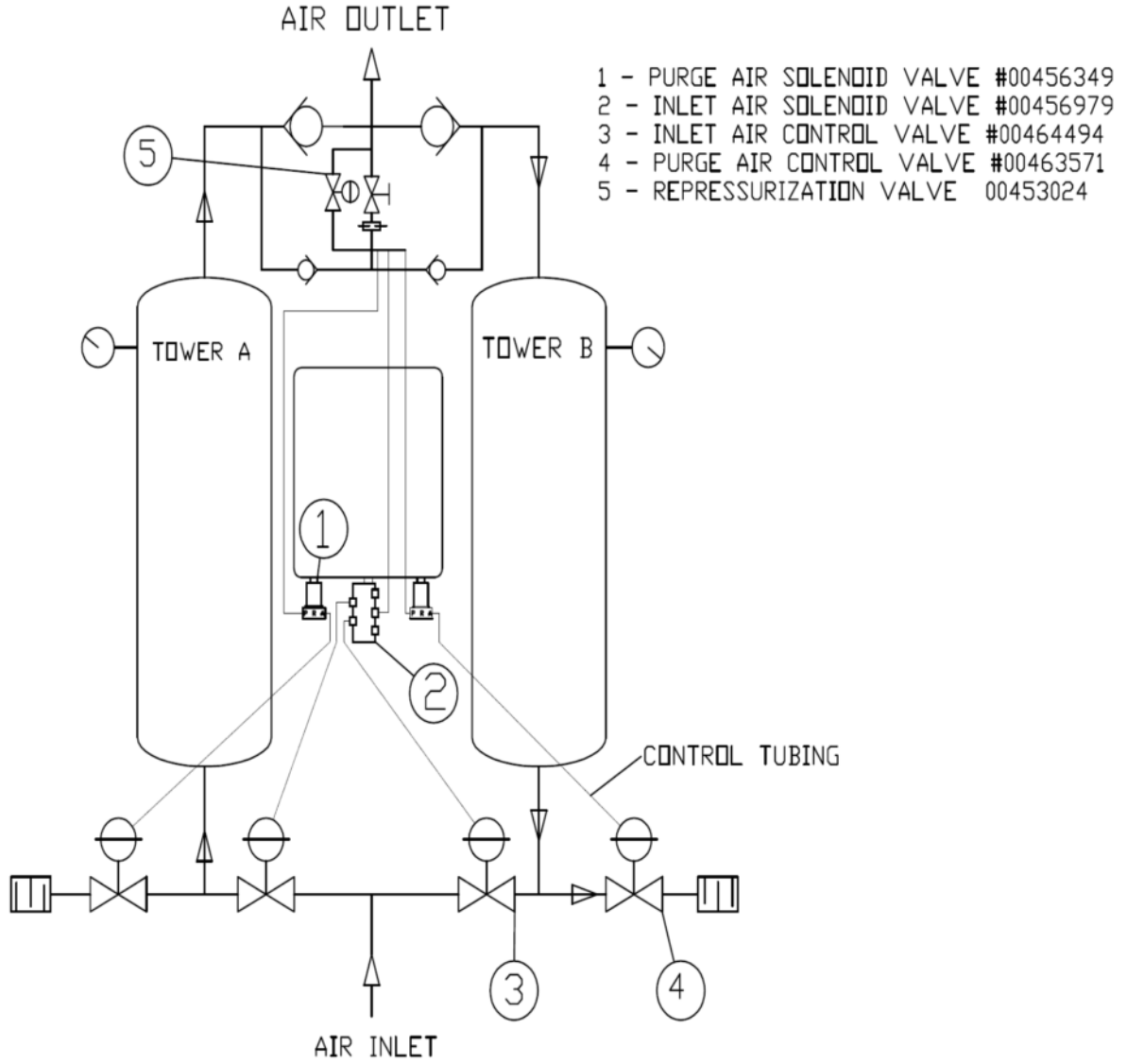

ELECTRICAL SCHEMATIC

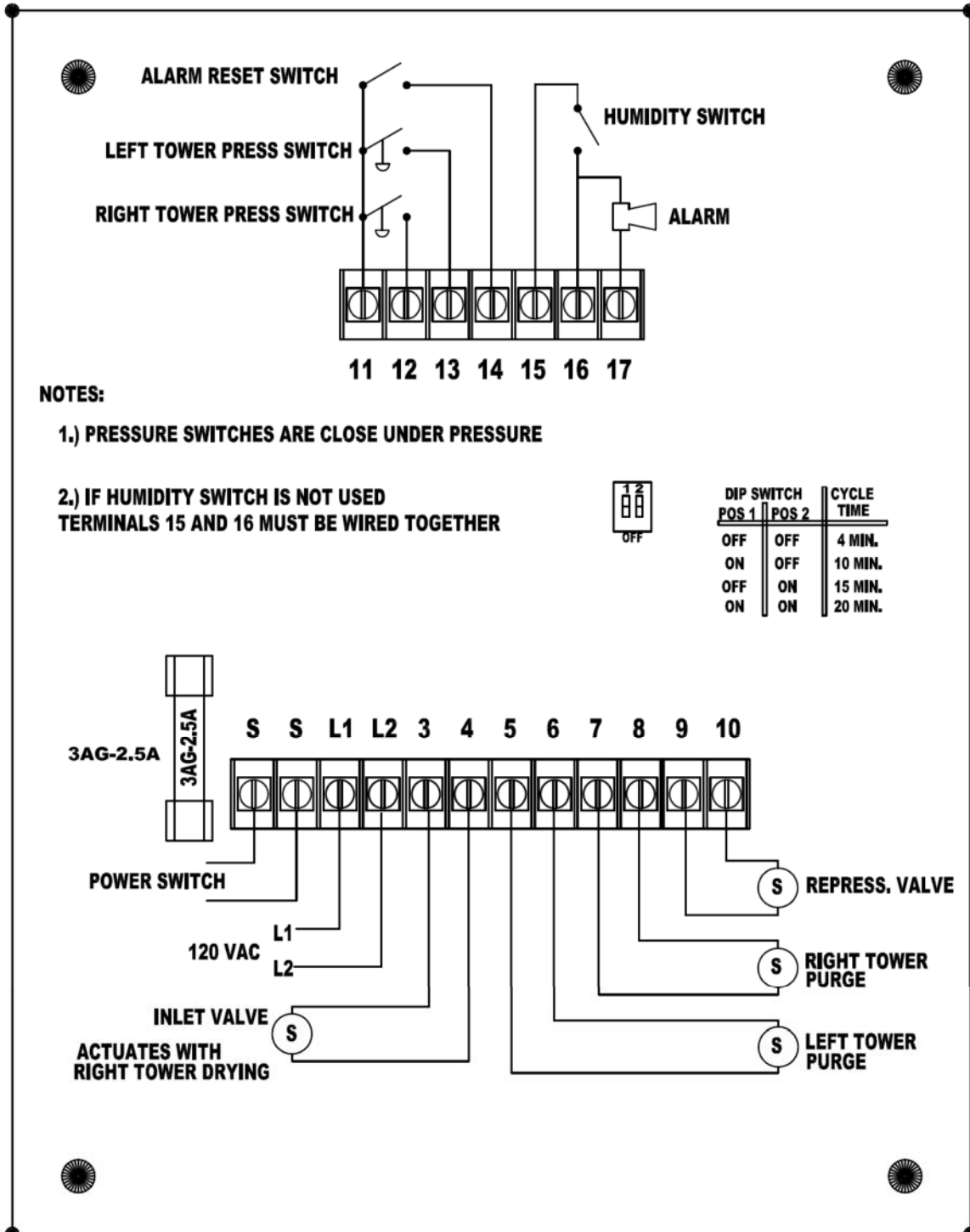

ECONO-PURGE CONTROLLER (OPTIONAL)

NOTE: At initial startup and during the first six months of continuous dryer operation, the Econo-Purge Controller logic SHOULD NOT BE ACTIVATED. A conditioning process must occur in new desiccant, this will allow the desiccant to remove its precise water vapor capacity from the airflow.

The function of EPC is to conserve energy by eliminating unnecessary dryer cycling, purge air consumption, and compressor power consumption.

The EPC works by utilizing a moisture sensitive probe to measure the water vapor content of the outlet air flow. The moisture content of the sample air stream indicates the wetness of the drying tower's desiccant bed. The purpose of the probe and its associated electronics is to first measure the "wetness" of the air within the desiccant beds and then regenerate the desiccant beds only when the moisture loading reaches a pre-set maximum, desired dew point.

The ECONO-PURGE CONTROL Plus is packaged with a digital dew point controller and High Humidity Alarm option. The digital dew point controller allows the end user to pre-set a desired dew point at which the dryer will start the Energy Savings Mode. This controller also allows the end-user to pre-set a dew point at which a high humidity alarm condition would occur. See High Humidity Alarm option for full description. See the digital dew point controller Owners Manual enclosed for changing desired dew points.

NOTE: Energy Savings to activate at -30° F humidity alarm is factory point.



Mode is factory preset dew point. High Humidity alarm is factory preset to +10° F dew

TROUBLESHOOTING GUIDE

PROBLEM	PROBABLE CAUSE	CORRECTIVE ACTION
Elevated Dew Point	Insufficient purge rate	<ol style="list-style-type: none"> 1. Check purge flow settings. 2. Check purge piping for obstruction 3. Clean purge piping and muffler
	Inlet air/gas pressure below source/design condition	<ol style="list-style-type: none"> 1. Check pressure
	Flow rate higher than design for condition	<ol style="list-style-type: none"> 1. Check flow rate and 2. Determine what caused increased demand
	Inlet temperature above design for condition	<ol style="list-style-type: none"> 1. Check after-cooler 2. Clean & service as necessary
	Entrained water entering the desiccant bed	<ol style="list-style-type: none"> 1. Check air/water separator drain operation 2. Check pre-filter drain operation 3. Replace desiccant and/or dryer if necessary
	Desiccant contaminated by oil	<ol style="list-style-type: none"> 1. Check pre-filter element 2. Check pre-filter drain operation 3. Replace desiccant and/or dryer if necessary
Excessive Pressure Drop in Air Dryer	Excessive flow rate	<ol style="list-style-type: none"> 1. Check flow rate 2. Located what caused increased demand
	Inlet pressure below design for condition	<ol style="list-style-type: none"> 1. Check pressure
Failure to Shift Towers from Drying to Regenerating Service	No input power	<ol style="list-style-type: none"> 1. Check input voltage
	Defective timer	<ol style="list-style-type: none"> 1. Check input and output voltages
	Defective solenoid valve	<ol style="list-style-type: none"> 1. Check input voltage to solenoid valve 2. Check outlet air flow from solenoid valve
	No pilot air	<ol style="list-style-type: none"> 1. Check pilot air-line for blockage 2. Check to see if pilot air-line filter is clean. 3. Replace element if needed
	Defective inlet valves	<ol style="list-style-type: none"> 1. Check pilot air source 2. Refer to steps above if no pilot air detected

TROUBLESHOOTING GUIDE

PROBLEM	PROBABLE CAUSE	CORRECTIVE ACTION
Dryer Fails to Pressurize	Faulty purge valve	<ol style="list-style-type: none"> 1. Check purge valve and its solenoid valve. 2. Refer to earlier steps if no pilot air is detected 3. Check timer sequencing
Dryer De-pressurizes Rapidly	Purge valve does not close; dryer depressurizing through purge valve	<ol style="list-style-type: none"> 1. Check purge valve and its solenoid valve 2. Refer to earlier steps if no pilot air is detected 3. Check depressurization timer circuit
Dryer Fails to Purge	Purge valve does not close; Purge valve stuck in closed position	<ol style="list-style-type: none"> 1. Check timer micro-switch 2. Check solenoid valve. 3. Repair and replace if necessary
	Purge muffler is clogged	<ol style="list-style-type: none"> 1. Refer to Purge Muffler replacement procedure.
Excessive Back-Pressure in Regenerating Tower (above 5 PSIG)	Purge muffler is clogged	<ol style="list-style-type: none"> 1. Refer to Purge Muffler replacement procedure.
	Outlet check valve stuck open	<ol style="list-style-type: none"> 1. Clean check valve 2. Replace check valve if issue persists

