



User's Guide

Models covered:

HRL-0015-1 through HRL-5000-1

Table of Contents

Section 1.0	Warnings and Precaution
Section 2.0	Getting To Know Your Dryer
Section 3.0	Installation
Section 4.0	Start Up
Section 5.0	Sequence of Operation
Section 6.0	Shutdown Procedure
Section 7.0	Maintenance
Section 8.0	Troubleshooting
Section 9.0	Timing Charts
Section 10.0	Specification Charts
Section 11.0	Correction Factors
Section 12.0	Drawings and Parts List
Section 13.0	Warranty
Section 14.0	Electronic Demand Control
Section 15.0	Advanced Options & Features

To Our Valued Customer,

We would like to thank and congratulate you on your selection of the Altec AIR's HLR Series Heatless Dryer. The Altec AIR represents the most reliable solution for your air drying needs. The design of the Altec AIR is easily understood and system set up, operation and maintenance are a snap. With fewer moving and more robust components than comparative units, your dryer is designed to provide you with years of trouble free operation.

Should you at any time have any questions regarding the operation or usage of your HLR dryer, please contact Altec AIR or your area distributor:

Distributed by:

--

Thank you for choosing ***Altec AIR***



Page Intentionally Left Blank

Section 1.0 Warnings and Precautions



CAUTION



WARNING

Never service dryer or associated equipment while under pressure.

Always disconnect power before servicing dryer.





Always use eye and ear protection when working on or near dryer. Dryer exhaust ports can raise particles especially when a unit is being operated without mufflers.

Be advised that noise level out of exhaust ports is higher during initial blow-down or depressurization of dryer towers.

Component failure from a lack of maintenance can result in a large air loss and/or high pressure loss across dryer. In the event of this occurring, bypass air around dryer to restore flow and pressure. NOTE: Recommended maintenance schedule should be followed to minimize the chances of this occurring. For recommended maintenance on dryer, please refer to **Section 7.0 Dryer Maintenance**.

Dust from Activated Alumina desiccant is considered a nuisance dust. Proper precautions should be taken when handling desiccant.

For proper disposal of desiccant, please refer to MSDS. Also be sure to comply with any local codes and regulations. Note that desiccant contaminated with oil or other foreign substances may require that you follow disposal requirements for that particular contaminant.

 WARNING	 ATTENTION
NEVER work on the system while it is under pressure!	Ne jamais travailler sur le système alors qu'il est sous pression
DISCONNECT POWER and TAG OUT prior to performing service.	Couper l'alimentation électrique et étiqueter avant le service d'effectuer
DO NOT USE for breathing air.	Ne pas utiliser pour respirer de l'air
Failure to follow instructions may result in severe injury or death	Le non-respect des instructions peut entraîner des blessures graves ou la mort
 CAUTION	 PRUDENCE!
Use TWO WRENCHES when installing piping.	Utilisez deux clés pour l'installation des tubes
DO NOT cycle with air compressor.	Ne roulez pas avec compresseur d'air
Read and follow all instructions before operating the unit.	Lisez et suivez les instructions avant système d'exploitation
Failure to follow instructions may result in severe injury or death	Le non-respect des instructions peut entraîner des blessures graves ou la mort

Section 2.0 Getting to Know Your Dryer

Each Altec AIR HRL Heatless dryer shares a common design platform.

The air or gas is dehydrated to the specified dew point in the drying towers through pressure swing adsorption and regeneration.

Understanding the key components to your dryer and performing maintenance at reasonable intervals will assure a long reliable life.

This chart and drawing will help you to identify the common components for your HRL model. It can also be used when calling for support to identify items quickly.

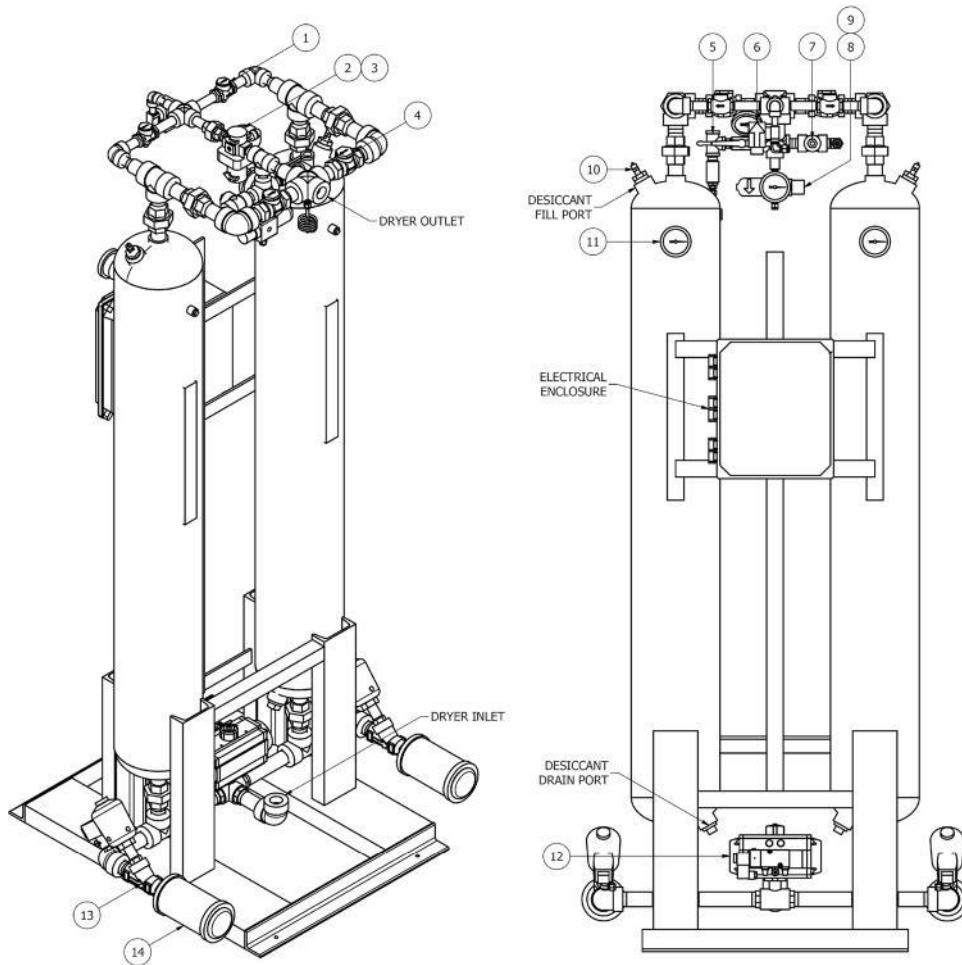

PARTS LIST		
ITEM	QTY	DESCRIPTION
1	2	CHECK VALVE, PURGE
2	1	PRESSURE REGULATOR, PURGE
3	1	PRESSURE GAUGE, PURGE
4	2	CHECK VALVE, OUTLET
5	1	DEW POINT MONITOR (OPTIONAL)
6	1	SOLENOID VALVE, REPRESS
7	1	MOISTURE INDICATOR
8	1	PRESSURE REGULATOR, CONTROL
9	1	PRESSURE GAUGE, CONTROL
10	2	RELIEF VALVE, TANKS
11	2	PRESSURE GAUGE, TANKS
12	1	3 WAY BALL VALVE, INLET
13	2	ANGLE BODY VALVE, EXHAUST
14	2	MUFFLER, EXHAUST

Section 3.0 Installation

Inspect shipping crate for any damage. If any damage is found notify freight carrier immediately so freight claim can be filed.

1. If no external damage to shipping crate is found remove crate from dryer.
2. Inspect dryer for any concealed damage. If any concealed damage is found, notify freight carrier immediately so freight claim can be filed.
3. Be sure to install dryer in an area where it can easily be accessed for maintenance. With this in **mind, we recommend a minimum of 30" on all sides of dryer.** Note that clearance requirements may vary depending on model. Refer to the applicable general arrangement print or contact the factory if clearance requirement for your dryer is needed.
4. Dryer should be installed in a clean, well lit area on a level surface where vibration is not present.
5. Standard dryers should be installed in an environment with an ambient temperature range of 40°F to 130°F. Please contact the factory regarding applications that run outside this range.
6. Check all piping and electrical connections to ensure nothing came loose during shipment. Loose piping or electrical connections can lead to improper operation of dryer.
7. Connect dryer to air system. Refer to installation drawing in Section 12.0 for dryer air in/out connection points. For ease of installation, air outlet can be connected at 2 different points. Refer to installation drawing for location of these connections. Be sure that all piping used is supported properly and is at least the same size as the dryer inlet and outlet connections.
8. Install isolation valves at dryer inlet and outlet.
9. Install bypass around dryer if one was not provided with your unit.
10. Exhaust ports on dryer can be piped to another location if desired. If you decide to pipe your exhaust ports to another location, you must ensure that no backpressure is in either tower while they are regenerating. Please upsize your exhaust piping accordingly. Exhaust ports should also be piped away individually. Please contact the factory for proper requirements for your application.
11. If you are installing your own coalescing pre-filter (not factory mounted), be sure to install it as close to the dryer as possible.
12. Note that if there is not a factory mounted after filter on your dryer, desiccant dust will travel downstream of dryer which can result in excessive wear or damage to downstream equipment. If this applies to the application you are running your dryer in, please install a particulate after filter before starting dryer.
13. **Make electrical connection to dryer. Refer to dryer's electrical schematic for location of connection points.** Note that you are responsible for providing short circuit protection for the dryer. See Section 3.1 for where to power the dryer.
14. **Read and understand entire operator's manual** before proceeding with start-up of equipment.

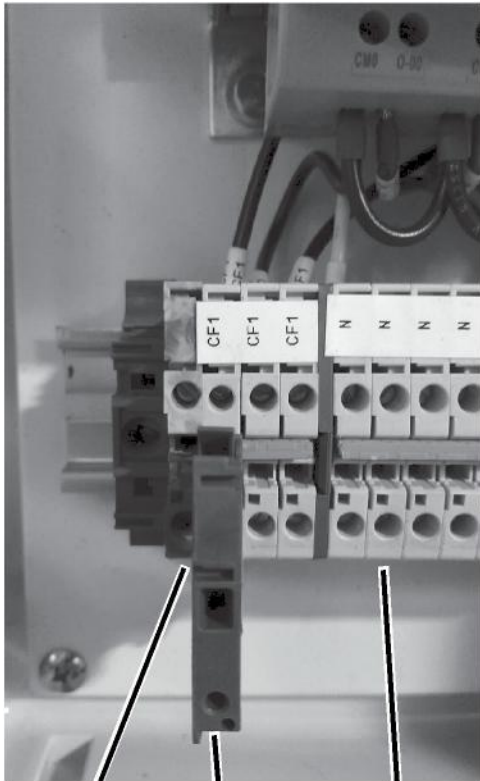

Ground L1 Neutral

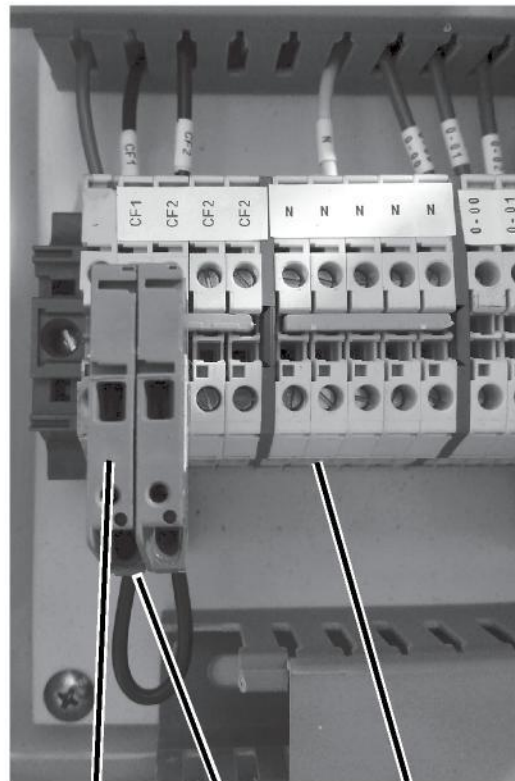

Ground L1 Neutral

Installation Notes:

- Ensure all drainage upstream of dryer is working properly before commissioning dryer. A desiccant dryer is designed to remove water vapor only. Oil and/or liquid entering the dryer will result in premature failure of desiccant as well as poor dew point performance.
- All units are provided factory charged with desiccant. No field desiccant charging is required. Only use approved desiccant.
- The location of an air receiver in an air system will depend on the application that the dryer is installed in. If you are uncertain if a dryer should be installed before or after an air receiver, please contact the factory for recommendations for your system.

Section 4.0 Start Up

You now have your dryer installed and are ready to go. Here are is a quick checklist to review before you get started:



Read and understand entire manual. Feel free to contact Altec AIR if you are unsure of anything in the manual. We will be happy to assist you with whatever you need to make sure you are comfortable with the unit before starting it.



Make sure there is not any air flow running through dryer. If there is, be sure to close air isolation valves or open air bypass around dryer before commencing with start-up. Check pressure gauges for "0" PSIG Reading.



Even though we want no air pressure on the dryer at this point, you do want to make sure that your air compressor is in service and your air system is pressurized, ready to feed the unit when we (you) hit the next step.

Thanks for taking the time to review your pre start-up checklist. If you have checked off all of the above, **you are now ready. Let's start your Altec AIR HRL Series Heatless Dryer! Here is a step-by-step** procedure to follow. By the end you will begin to experience the benefits of the dry air that you paid for by purchasing our product.

STEPS:

1. As you did prior to installation, inspect the unit to ensure that there is no damage that happened during shipment or installation. If you do see any damage, please contact Altec Air immediately with a description of what was found.
2. Remove the mufflers from dryer exhaust valves, if installed
(Mufflers Typically Ship Loose on AL series Dryers)



WARNING: Tower depressurization will be very loud without mufflers. Ensure that proper ear protection is worn and no personnel are in the exhaust stream before proceeding. Always exercise caution when working with compressed air.



3. Apply power to dryer. Be sure to review the wiring diagram for your unit. Make sure proper short circuit protection is provided and all applicable electrical codes are followed.

4.1

4. When unit is initially powered up, the display will illuminate.

- b. After the start up screen, if the unit does not display "System In Standby", move the Run/Standby Switch (Fig.1) located on the control box side to the Standby Position.
- a. Verify that the Programmable Logic Controller Screen (Fig. 2) becomes illuminated and a message center appears.



Fig.1



Fig.2

5. Move run/standby switch from standby position to run position. If a run cycle is not chosen, the unit will start-up automatically in the minute cycle after 2 minutes.

6. Press "V" to begin the 10 minute cycle cycle.

Page Intentionally Left Blank

4.3

- Unit will now display Pressurizing System. During this time slowly introduce air to the dryer by closing the air bypass and/or opening dryer isolation valves.

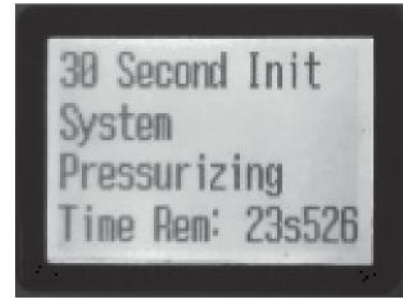

- After 30 second pressurization step, unit will automatically step into the selected run mode.

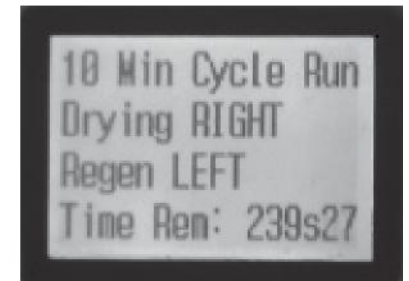

- Verify that tower pressure gauges are reading close to line pressure while drying and at zero pressure when regenerating (Note that there will still be flow coming from the open exhaust valve on the regenerating side tower, but no pressure should register on the gauge). On Models 100 scfm and larger, verify the purge is set to the proper pressure per tag on regulator.



- Allow unit to run 2 complete cycles without mufflers installed on exhaust valves.



- Set the unit back to standby before reinstalling muffler valves. After mufflers are installed, set the unit back to run and press OK to restart the cycle.



OPERATIONAL NOTES

Indicates Current Step in Cycle

Timer will count down indicating how much time is remaining in current step in cycle.

Pressing the Up Arrow & Left Arrow at the same time will allow you to manually step the dryer to the next step in the cycle.



Turn switch to **RUN MODE** to initiate operation
 Unit will auto start in 2 minutes in **FACTORY RECOMMENDED CYCLE** (10 minute)
 Consult Operators Manual for cycle adjustment instructions and additional features
 Turn switch to **STANDBY** when not in use

Turn Eco Switch **ON** to initiate **ECO MODE**
 Unit will cycle based on dew point condition when in **ECO MODE**
 Standard setting for **ECO** is -40 F/C to initiate switching
 Consult manual to adjust **ECO** setting and **HIGH DEW POINT ALARM**

Made in the USA

Section 5.0 Sequence of Operation

Your dryer is controlled by an Allen Bradley Micro 810 Programmable Logic Controlled System. The dryer PLC is the brain of the system and controls the following:



The 3-way inlet valve which allows air flow to the online or drying tower.

The exhaust solenoids which open on the regenerating side tower to allow the moist purge air to leave the machine.

A solenoid to quickly repressurize the tank after regeneration.

To change your dryer cycle see 4.1 for basic instructions and 15.1 for advanced operation.

On 100 SCFM and larger units, there are also 4 check valves in the upper line set of the dryer (2 purge & 2 outlet) which distribute air properly out to your process & through the purge circuit for the air needed to regenerate the off line tower.

Here is the sequence your dryer will follow once it is in the run mode: **Step 1;**

Right Tower Drying, Left Tower Regenerating

There will be no output from 0-00 on the PLC, leaving the 3-way inlet valve in its neutral state, to allow the wet air flow through the right tower of the dryer. The air will be dried as it passes through the right side drying tower. The air will exit the right side drying tower and flow through the right outlet check valve & through the dryer outlet. During this time, the right tower pressure gauge should read line pressure (approximately 100 psig).

After a short delay, an output from 0-02 on the PLC will energize and open the left tower

exhaust solenoid allowing the regenerating left side tower to first depressurize, then to allow the purge air to flow from the dryer outlet, through the purge regulator & purge orifice, then through the left side purge check valve. The purge flow will strip the moisture off of the desiccant bed and exit through the open exhaust valve and out of the muffler. During this time, the left tower pressure gauge should read 0 psig.

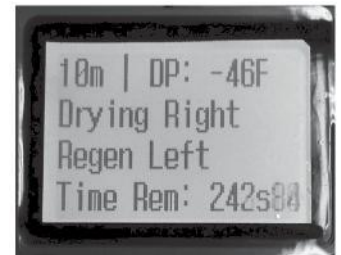

Step 2; Right Tower Drying, Left Tower Repressurizing

During this step, the dryer will continue to dry on the right side so an output from the PLC on 0-00 will remain off to keep the 3-way inlet valve in the same position. During this time the right tower pressure gauge should continue to read line pressure (approximately 100 psig) The output from 0-02 on the PLC however will no longer be present, which will close the left tower exhaust valve.

At the same time an output from 0-03 on the PLC will energize the repressurization solenoid which will allow additional air flow from the purge line to the left tower. You should see the left side tower begin to pressurize and come to full line pressure (approximately 100 psig) at the completion of this step. The purge gauge will be reading line pressure (approximately 100 psig) during this step.

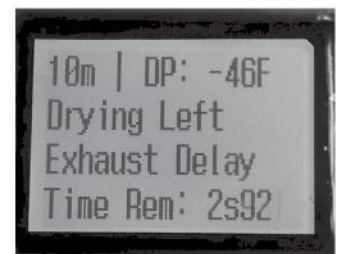

Step 3; Left Tower Drying, Right Tower Regenerating

An output from 0-02 on the PLC will move the 3-way inlet valve to allow the wet air flow through the left tower of the dryer. The air will be dried as it passes through the left side drying tower. The air will exit the left side drying tower and flow through the left outlet check valve & through the dryer outlet. During this time, the left tower pressure gauge should read line pressure (approximately 100 psig).

After a short delay, an output from 0-01 on the PLC will energize and open the right tower exhaust solenoid allowing the regenerating right side tower to first depressurize, then to allow the purge air to flow from the dryer outlet, through the purge regulator & purge orifice, then through the right side purge check valve. The purge flow will strip the moisture off of the desiccant bed and exit through the



open exhaust solenoid and out of the muffler. During this time, the right tower pressure gauge should read 0 psig.

Step 4; Left Tower Drying, Right Tower Repressurizing

During this step, the dryer will continue to dry on the left side so an output from the PLC on 0-00 will remain to keep the 3-way inlet valve in the same position. During this time the left tower pressure gauge should continue to read line pressure (approximately 100 psig).

The output from 0-01 on the PLC however will no longer be present, which will close the right tower exhaust solenoid.

At the same time an output from 0-03 on the PLC will energize the repressurization solenoid which will allow additional air flow from the purge line to the right tower.

You should see the right side tower begin to pressurize and come to full line pressure (approximately 100 psig) at the completion of this step.

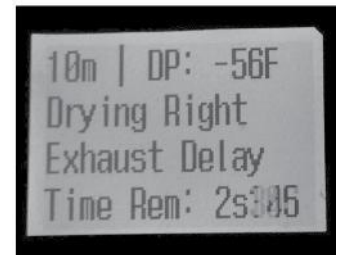
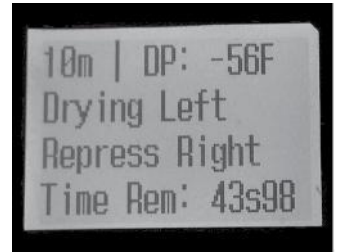

GENERAL NOTE: On units sized for 1000 SCFM and above, the 3-way valve is replaced with two inlet butterfly valves in addition to two timer relays set to a delay of 4 seconds. The user should expect that the Timing charts in section 9.0 and the above Sequence of Operation to vary between these larger and smaller units. Timing will also change depending on selected cycle time explained in section 15.XX.

Section 6.0 Shut Down

Here is a quick step-by-step procedure to shut your dryer down properly.



WARNING

When shutting the dryer down, always be sure to bypass the unit prior to commencing with shut down. Failure to bypass unit and/or attempting to work on a unit under pressure may result in severe injury or death.

PRESSURE GAUGES SHOULD READ “0” PSIG BEFORE COMMENCING

1. Open bypass valve(s) slowly to allow air flow to bypass dryer.

2. Close inlet and outlet isolation valves (usually installed independently of dryer in piping system) to dryer to remove air flow, or shut down air compressor.



3. Verify that the pressure vessels are reading 0 PSIG. You relieve pressure through the drain system.

4. Turn Run/Standby Switch on Dryer to Standby position.



5. Remove power from supplied 115v/1/60 electrical plug. By either unplugging the 115V/1Ø/60Hz electrical plug, or removing the fuse.

6. Commence Maintenance (Dryer maintenance can be found in SECTION 7.0).

Section 7.0 Maintenance

You probably have noticed already that your Altec AIR, HRL Series heatless dryer has very few moving parts. There are, however, a few items that you will need to maintain to ensure your dryer is operating at its best. Please be sure to follow this schedule regularly and you will have a reliable piece of equipment you can count on for many years to come. Here is the recommended maintenance schedule for your dryer:

	Weekly	Monthly	Semi- Annual	Annual
Check Moisture Indicator	X	X	X	X
Verify Purge Setting	X	X	X	X
Check Auto Drain	X	X	X	X
Verify No Back Pressure In Regen. Tower	X	X	X	X
Check Filter DP Gauges	X	X		
Replace Moisture Indicator				X
Replace Exhaust Mufflers				X
Remove 1 cup Desiccant Sample from Each Tower. (Contact EAP for RMA number to return sample)				X

Desiccant Replacement

The desiccant charge in your unit will need to be replaced, on average, every 3-5 years. Some units may require replacement of the desiccant charge more frequently. Be sure to return desiccant samples for testing annually to confirm the condition of your desiccant charge. To replace your desiccant charge follow these steps:

1. Bypass air flow around dryer.
2. Remove power from dryer.
3. Depressurize dryer by pressing drain test button. Repeat until there is no pressure remaining on any gauge on unit.
4. Remove desiccant drain plug from bottom of each tower. Be sure to have adequately sized container(s) to put desiccant into for disposal.
5. Reinstall desiccant drain plugs on each tower.
6. Remove safety relief valves on top of each tower.
7. Charge each tower with correct charge of Altec AIR activated alumina.
8. Reinstall safety relief valves on each tower.
9. Slowly repressurize dryer.
10. Reapply power to dryer.

NOTES:

Be sure to use Altec AIR desiccant. Failure to do so may result in a voided warranty and/or a reduction in performance of your unit.

Consult Altec AIR for desiccant MSDS for proper disposal instructions. Also be sure to follow all local regulations for disposal of desiccant. Note that desiccant contaminated with other may require that the disposal requirement for that particular contaminant be followed.

Section 8.0 Troubleshooting

NW SERIES TROUBLESHOOTING GUIDE		
Power to 3-way inlet valve, but not responding	1. Verify correct Voltage has been applied to unit	Move dryer to a different power source
	2. Check dryer wiring schematic to verify correct wiring	Correct the wiring
3-way inlet valve actuator humming	1. Ensure proper voltage to valve and make sure all connections are tight	Move dryer to a different power source/ or tighten connections
	2. Make sure the dryer is properly grounded	Ground unit properly
Actuator on 3-way valve performs erratically	1. Check to see if actuator is not stalling. Remove actuator from valve to verify valve moves freely.	If valve turns freely, replace valve, if not replace actuator
	2. Make sure solenoid exhaust ports are not blocked or clogged with dirt. This will prevent the actuator from functioning properly.	Clean solenoid mufflers
Exhaust solenoid leaking air drying tower side	1. Valve is dirty	Clean valve
	2. Defective diaphragm or O-rings	Replace valve
	3. Verify no voltage from PLC	If voltage, reprogram or replace PLC
High Pressure drop across the unit	1. Clogged pre or after filter element	Replace clogged element
	2. Inlet valve or check valve leak	See back pressure in regenerating tower
Back pressure in regenerating tower	1. Clogged muffler	Replace mufflers always replace both
	2. Outlet check valve on drying side leaking	Replace check valve
	3. Purge check valve on drying side leaking	Replace check valve
	4. 3-way inlet valve not operating properly	See 3-way inlet valve troubleshooting

Section 9.0 Timing Charts

Programmable Logic Controller Timing Sequence by Cycle:

When operating your Altec AIR, the PLC will output signals controlling valve positions. The below chart may be used as a reference to timing of system valves and testing for proper PLC functions. Be sure to press ESC to go back to Cycle Select before modifying cycle times.

10 Minute Standard Cycle

	Step 1 246 Seconds	Step 2 50 Seconds	ECO (Ecotronic Only)	Exhaust Delay 1 4 Seconds
	Right Tower Drying Left Tower Regenerating	Right Tower Drying Left Tower Repressurizing	Right Tower Drying Left Tower Standby	Left Tower Drying Right Exhaust Delay
O-00				
O-01				
O-02				
O-03				

	Step 3 246 Seconds	Step 4 50 Seconds	ECO (Ecotronic Only)	Exhaust Delay 2 4 Seconds
	Left Tower Drying Right Tower Regeneration	Left Tower Drying Right Tower Repressurizing	Left Tower Drying Right Tower Standby	Right Tower Drying Left Exhaust Delay
O-00				
O-01				
O-02				
O-03				

5 Minute Short Cycle

	Step 1 96 Seconds	Step 2 50 Seconds	ECO (Ecotronic Only)	Exhaust Delay 1 4 Seconds
	Right Tower Drying Left Tower Regenerating	Right Tower Drying Left Tower Repressurizing	Right Tower Drying Left Tower Standby	Left Tower Drying Right Exhaust Delay
O-00				
O-01				
O-02				
O-03				

	Step 3 96 Seconds	Step 4 50 Seconds	ECO (Ecotronic Only)	Exhaust Delay 2 4 Seconds
	Left Tower Drying Right Tower Regeneration	Left Tower Drying Right Tower Repressurizing	Left Tower Drying Right Tower Standby	Right Tower Drying Left Exhaust Delay
O-00				
O-01				
O-02				
O-03				

Section 10.0 Specification Chart

Model	Flow SCFM@ 100 PSIG	Design Inlet °F (°C)	Air Inlet/Outlet NPS	Purge Rate SCFM @ 100 PSIG	Orifice Size Inches	Purge Pressure Setting (psig)	Desiccant Per Tower (lbs)	Standard Voltage (Volt / Ø / Hz)	Fuse (amps)
HRL-0015	15	100 (38)	1/2	2.25	NA	NA	10	115v/1/60	3
HRL-25	25	100 (38)	1/2	3.75	NA	NA	15	115v/1/60	3
HRL-40	40	100 (38)	1/2	7.5	NA	NA	25	115v/1/60	3
HRL-75	75	100 (38)	1	11.25	NA	NA	45	115v/1/60	3
HRL-100	100	100 (38)	1	15	3/16	31	55	115v/1/60	3
HRL-130	125	100 (38)	1	19.5	3/16	45	70	115v/1/60	3
HRL-200	200	100 (38)	1 1/2	30	1/4	37	110	115v/1/60	3
HRL-250	250	100 (38)	1 1/2	38	1/4	50	140	115v/1/60	3
HRL-300	300	100 (38)	1 1/2	45	1/4	62	165	115v/1/60	3
HRL-400	400	100 (38)	1 1/2	60	3/8	31	225	115v/1/60	3
HRL-500	500	100 (38)	2	83	3/8	42	275	115v/1/60	3
HRL-650	650	100 (38)	2	98	3/8	60	330	115v/1/60	3
HRL-800	800	100 (38)	2	120	7/16	52	440	115v/1/60	3
HRL-1000	1000	100 (38)	3	150	1/2	50	550	115v/1/60	3
HRL-1250	1250	100 (38)	3	187	5/8	36	675	115v/1/60	3
HRL-1500	1500	100 (38)	3	225	5/8	47	825	115V/1/60	3

Dryer Specification Data

Customer Name: _____

Purchase Date: _____

Dryer Serial No.: _____

Tanks Nation Board _____

& _____

No's.: CRN No: _____

(where applicable)

Inlet pressure: Inlet _____

(min.) _____

(max.) _____

Temperature: _____

(std.) _____

(max.) _____

Options /

Notes: _____

Section 11.0 Correction Factors

HRL Series Dryers are designed to provide a -40 degree F/C pressure dew point based on inlet conditions as defined by the Compressed Air and Gas Institute ADF100 Standard of 100 degree F Inlet Air Temperature, 100 PSIG Inlet Air Pressure and rated unit flow. To determine rated unit flow for pressures other than 100 PSIG consult the chart below. Never operate a unit below 60 PSIG without first consulting the factory.

MODEL					
	60	80	100	120	140
Purge Rate	23.0%	18.1%	15.0%	12.8%	11.1%
HRL-0015	10		13	5	8
HRL-0025	16		21	25	30
HRL-0040	26		33	40	47
HRL-0075	49		62	75	89
HRL-0100	65		83	100	118
HRL-0125	81		104	125	148
HRL-0200	130		166	200	236
HRL-0250	163		208	250	295
HRL-0300	195		249	300	354
HRL-0400	260		332	400	472
HRL-0500	325		415	500	590
HRL-0600	390		498	600	708
HRL-0800	520	664	800	944	1096
HRL-1000	650	830	1000	1180	1370
HRL-1250	812	1,037	1,250	1,475	1,712
HRL-1500	975	1,245	1,500	1,770	2,055

Factor Degrees F

For applications where inlet temperature is not 100 degrees F, use the below chart to apply a correction factor to determine net capable flow:

Factor Degrees F

Example:

Model HRL-100 operating at 120 PSIG and 120 F Inlet Temperature
 Rerate for pressure = 126 SCFM X 0.85 (correction factor for temperature) = 107
 New Rated Flow = 107 SCFM

Section 12.0 Drawings and Parts List

Select your product from the below matrix to identify the parts list and drawing set that matches your dryer. Contact Altec AIR, or your local Dealer to obtain support for your unit.

Model	General Arrangement	Electrical		P & ID
	PDF	Standard	EcoTronic	PDF
HRL-0015	HRL20-372	HRL40-1092	HRL40-1094	HRL50-1122
HRL-0025	HRL20-375			
HRL-0040	HRL20-1272			
HRL-0075	HRL20-393			
HRL-0100	HRL20-395			
HRL-0125	HRL20-1273			HRL50-761
HRL-0200	HRL20-354			
HRL-0250	HRL20-398			
HRL-0300	HRL20-1274			
HRL-0400	HRL20-401			
HRL-0500	HRL20-370			
HRL-0600	HRL20-1275			
HRL-0800	HRL20-387			

Typical Spare Parts List

Item No.	Description	Quantity	Recommended Interval			On Hand
			6 Month	Annual	3-5 Years	
1	Muffler, Exhaust	2	X			X
2	Desiccant, Alumina	XXX			X	
3	Valve, Inlet	1			X	
4	Valve, Inlet Actuator	1				
5	Valve, Exhaust	2				
6	Valve, Purge Regulator	1				
7	Valve, Purge Check	2				
8	Valve, Outlet Check	2				
9	Repair Kit, Purge Check	2			X	
10	Repair Kit, Outlet Check	2			X	
11	Controller, PLC	1				
12	Moisture Indicator	2				X
13	Fuse, 3 amp	1				X
Options:						
14	Probe, Dew Point Sensor	1				
15	Valve, Bypass	3				

Section 13.0 Warranty

Your Altec AIR HRL series heatless dryer will carry a warranty on any defect in material and workmanship on the dryer for a period of 2 years from the date of shipment. The first year of coverage will cover both replacement parts and labor time to install per our warranty rate schedule. First year warranty may be extended to 18 months from date of shipment where installation is delayed. Consult factory to verify extended warranty coverage. The second year of coverage (or remaining period of 24 months from date of shipment) will cover replacement parts only with labor time NOT being covered.

Altec AIR will not assume responsibility for any contingent liability caused by the alleged failure of any of our product or accessories.

The above warranty will also NOT cover any failure resulting from improper installation of the dryer. So be sure to review the Getting Started section of your manual before starting your dryer. Improper installation can lead to premature failure of then dryers' desiccant and other components, caused by among other things, liquid slugging, excessive vibration, or excessive desiccant dusting.

In the event you do have a situation arise where you will need to utilize your dryer warranty, here is the procedure you will need to follow:

PROCEDURES FOR MAKING A WARRANTY CALL:

1. Record the model and serial number of your dryer along with a description of the problem you are having.
2. Contact Altec AIR to advise us of the problem you are having. We will request the information above from you.
3. Once the issue or problem component is identified, we will request a purchase order from you for to send out the replacement part you need.
4. Once the replacement purchase order has been processed, we will send out are placement part for you.
5. Along with the replacement part, we will send you a Return Material Authorization form and a labor authorization form (if you are in the first year of coverage) with instructions on how to return the defective part from your dryer and how to file a claim for the labor coverage. Both forms will also be sent to you electronically at the time of the part shipment.
6. Once the defective part returns to us, it will be evaluated and if found to be warrantable, credit will be issued to you on the order for the replacement part.
7. If labor coverage applies, your claim will be reviewed upon receipt and credit will be issued to your account per our warranty rate schedule.

Section 13.1

Altec AIR
Warranty Rate Schedule
HRL Series Dryers

Dryer Component	Time to Replace
Purge Regulator	1.0 hours
Repressurization Valve	1.0 hours
Pressure Gauge	0.25 hours
Drain Assembly	PARTS COVERAGE ONLY
Exhaust Solenoid	1.0 hours
Purge Check Valve	1.0 hours
Outlet Check Valve	1.0 hours
Inlet Valve	1.0 hours
Control Board	2.0 hours
Warranty Labor Rate	\$65.00 per hour
Warranty Travel Rate	\$65.00 per hour (max 4 hours)

Altec AIR has no other warranty whatsoever, expressed or implied and all warranties of merchantability and fitness for a particular purpose are hereby disclaimed by Altec AIR. Altec AIR shall in no case, be subject to any obligation or liability whatsoever with respect to product or services manufactured or furnished by it or any acts of omission relating thereto.

The remedy provided under this warranty shall be the sole, exclusive, and only remedy available to the purchaser. Under no circumstances shall Altec AIR be liable for any special indirect, incidental, or consequential damage, losses or delays however caused.

Section 14.0 Electronic Demand Control

PRECAUTIONS USING THE ECOTRONIC

The Electronic Demand Control uses state-of-the-art microelectronics to provide a compact full functioning instrument. The user should consider the following precautions when using any sensitive electronic device.

- Observe the appropriate electrical safety codes and regulations. Consult with National Electrical Code article 400, and/or other nationally or locally recognized procedures relevant to your installation. This instrument is UL approved for field wiring.
- Do not install the unit near a heat source such as a radiator or air duct.
- Do not install the unit in places subject to extreme mechanical vibration or shock. If this is not avoidable, use resilient mounting. If in doubt, please contact us.

DEW POINT CALIBRATION SYSTEM FEATURES AND OPERATION (DCS/ECO)

- Unit will be put into a standby ECO mode if the dew point remains at or below the set point value for 1 minute. This check is done after each cycle pressurization step. (Fig. 1)
- Unit will remain in ECO if the dew point is at or below the set point value (Default -40°F).
- Unit will only remain in ECO mode for a maximum of 1 week before advancing to the next step.
- After the unit has finished an ECO step, it will display "ECO Hold" for 3 drying cycles on each tower. During this time the unit will not enter an ECO step. ECO hold will end on the opposite tower that went into ECO, and will attempt to re-enter ECO.
- If DCS is turned off, the readout will flash between "DCS Off" and the current dew point reading, unless the dew point monitor fails, in which it will read "DP Failure".
- If dew point value is out of range, it will display "DP Failure" and prevent ECO

mode. CHANGING THE DEW POINT SET POINT

- Default and recommended set dew point for normal operation is -40°F. (Fig. 2)
- Default and recommended dew point alarm is set to -20°F. (Fig. 3)
- Press " " > on the cycle select or cycle run display to bring up the Dew Point Set menu.
- Press v > on the cycle select or cycle run display to bring up the Dew Point Alarm menu.
 - Press " " for +1°F
 - Press > for +5°F
 - Press v for -1°F
 - Press < for -5°F
 - Press OK to confirm selection



Fig. 1



Fig. 2



Fig. 3



Easidew Transmitter Installation Instructions

Verify that your dew point package includes the following:

Easidew Transmitter

HDPE Guard

5/8-18 UNF X 1/2 NPT Bushing (May already be installed on Sample Cell)

Seal Washer

1. Insure that the protective cover, and it's desiccant capsule, have been removed from the tip of the transmitter body.
2. Install the seal washer over the threaded part of the transmitter body.
3. Screw the transmitter into the sample block and tighten to a minimum torque setting of 22.5 ft-lbs. Use the flats of the hexagonal nut and not the sensor body.
4. Attach the transmitter cable/ connector assembly to the plug located at the base of the transmitter and tighten the retaining screw.

Refer to the Khan instruction manual provided for more information.

14.2 Specifications

Sensor Type:

Kahn Advanced Ceramic
Moisture Sensor

Measurement Range:

-148°F to +68°F (-100°C to +20°C) dewpoint
0 to 3000 PPMv moisture content

Accuracy:

±3.6°F (±2°C) dewpoint

Power Supply:

12-28 VDC reverse polarity protected

Output:

4-20 mA linear, current source
configurable over the entire
measurement range
Optional Modbus RTU
(see Easidew M12 above)

Operating Temperature:

-40°F to +140°F (-40°C to +60°C)

Operating Pressure:

Vacuum to 6500 PSIG

Temperature Compensated:

From -40°F to +140°F (-40°C to +60°C)

Flow Rate:

2 to 10 SCFH (1 to 5 l/min) mounted in
sampling block;
0 to 10 m/sec (0 to 30 ft/sec) velocity
when inserted directly

Connection:

2-wire loop powered DIN-style with
screw terminal contacts
Backward compatibility with
3-wire installations

Traceable Certification:

-100°F to +68°F dewpoint traceable
to NIST. For dewpoints < -100°F, direct
reference to a fundamental optical
dewpoint hygrometer

Environmental Protection:

IP66/NEMA 4
10μ HDPE Guard (standard)
80μ Sintered Guard (optional)

Weight:

0.33 pounds (0.15 kg)

Self Diagnosis:

<u>Condition</u>	<u>Output</u>
Sensor fault	3 mA
Under-range dewpoint	3 mA
Over-range dewpoint	21 mA

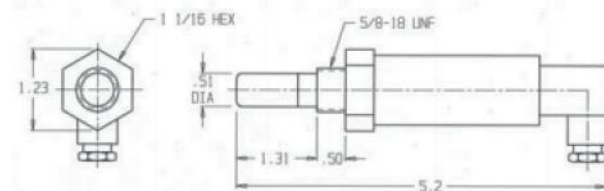

Easidew Transmitter

14.3 Dew Point Activation

- After 1 week worth of time since the unit was first cycled, it will begin to allow a dew point recovery mode to activate.
- Default value for the DP recovery delay timer is 168 hours (1 week) since the first time a cycle was selected. The operator can adjust this value in increments of +/- 1 or 5 hours, all the way down to 0 hours, allowing DP recovery from startup. This set value is retentive and will remain the same through a power loss. In addition, the delay timer will also be retentive. If the operator chooses, they may be able to reset this delay timer back to zero so that it may act as a new installation.
- DP Recovery mode will subtract 1 minute from the cycle time each hour that the dew point doesn't decrease at least 20% of the difference between the set dew point and the alarm set point. Display will flash "DP Recovery" over the cycle time when this is active.
- If the set dew point and alarm dew point are the same value, it will instead use a value of 4°F instead of 20% for checking the dew point.
- After the dew point has gone below the dew point set value (Default -40°F), it will return to whatever the previously selected cycle time was.
- DP Recovery will only lower the cycle time to a minimum of a 6 minutes.
 - The ability for the unit to go into DP recovery mode can be toggled on and off.
 - If DCS is turned off, unit will not go into DP recovery.

Press <v to bring up the menu for the Dew Point Recovery

Press ^ for +1 hour

Press > for +5 hours

Press v for -1 hour

Press < for -5 hours

Press ^> to reset the internal delay timer (so unit acts as a new installation)

Hold v> for 2 seconds to toggle Dew Point Recovery on/off

Press OK to confirm selection

Page Intentionally Left Blank

Section 15.0 Advanced Features and Options

PRESSURE SWITCH / COMPRESSOR LOCK

- The pressure switch will trigger the low pressure alarm if the unit has a consistent low pressure (set to 60 psi) for 5 seconds. (Fig. 1)
 - This timer is to prevent the alarm from rapidly triggering on and off.
- During the alarm, exhaust valves will close until pressure is restored to the dryer. 5 Seconds after the pressure is restored, the cycle will resume from where it left off.
- A timer will be displayed, counting down from 5 seconds until the cycle continues. If the pressure switch is triggered again during this time, the timer will reset. (Fig. 2)
- If the alarm is triggered while the dryer was in regeneration mode, it will skip the exhaust valve delay time to eliminate redundancy.
- When the pressure alarm is active, the LCD screen will display “Pressure Loss Waiting For Compressor”.
- The first time the low pressure alarm is successfully triggered, a 1 hour timer will begin. If the unit has 6 low pressure alarms within this 1 hour timer, the unit will close exhaust valves and halt all operations. “CRITICAL PRESSURE ALARM CALL FACTORY FOR ASSISTANCE” will be displayed.
- This message can be bypassed by pressing ESC, and will bring the operator back to the cycle select menu to resume operations. (Fig 3)



Fig. 1



Fig. 2

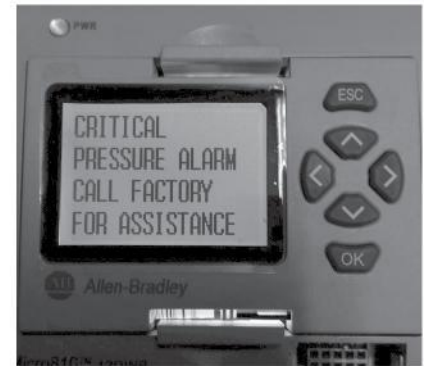

Fig. 3

CHANGING CYCLE TIMERS

CAUTION:

Consult factory before changing any of these timers. Improper use of these custom features may cause the dryer NOT to function properly or damage components.

Regeneration time is calculated with the following formula:

$$X_0 = \frac{\text{Total Cycle Time} - (\text{Total Repress Time} + \text{Total Exhaust Delay Time})}{2}$$

Where,

x0 = Regeneration Time

Total Cycle Time = Cycle time selected in cycle select menu

Total Repress Time = 2* (Selected repressurization time)

Total Exhaust Delay Time = 8 seconds

Cycle time can be changed between 5 minutes to 60 minutes.

10 minute cycle time is recommended for normal operation.

5 min cycle time is used for low dew point systems.

Press ESC to bring the dryer back to the cycle select menu. (Fig. 1)

Press " for +1 cycle minute

Press > for +5 cycle minutes

Press v for -1 cycle minute

Press < for -1 cycle minutes

Press OK to confirm selection and start cycle



Fig. 1

CHANGING REPRESSURIZATION TIME

Default repressurization time is 50 seconds.

DO NOT set the repressurization time lower than the time it takes for the tanks to equalize pressure.

Doing so can cause damage to the internals of the tank on tower switches. Press <> to bring up the Repressurization Menu (Fig. 2)

Press " for +1 second

Press > for +5 seconds

Press v for -1 second

Press < for -1 seconds

Press OK to confirm selection



Fig. 2

15.2 Input / Output Reference

I-00	DSC Switch	O-00	Inlet Valve, Active = Left Tower
	Drying		
I-01	Unused	O-01	Exhaust Valve, Right Tower
I-02	Run/Standby Switch	O-02	Exhaust Valve, Left Tower
I-03	Pressure Switch/Compressor Lock	O-03	Repressurization Valve
I-04	Analog Input, Dew Point Signal		
I-05	Analog Input, Unused		
I-06	Analog Input, Unused		
I-07	Analog Input, Unused		



AIR

226A Commerce Street
Broomfield, CO 80020
Phone 1-800-521-5351
Fax (303) 657-2205

AL Dryer

AL31721-1
Printed in the USA