



## ***OPERATING MANUAL***



## ***MODEL CDA10/CDA10-2 CLEAN DRY AIR PACKAGE***

## TABLE OF CONTENTS

1.0	GENERAL .....	3
2.0	SPECIFICATIONS .....	3
3.0	INSTALLATION AND START-UP PROCEDURES .....	4
4.0	PRINCIPLES OF OPERATION .....	4
5.0	COMPONENT DESCRIPTION.....	5
Figure 1	- Air Flow Diagram .....	5
5.1	CABINET .....	5
5.2	AIR COMPRESSOR.....	5
5.3	VENTILATING FAN .....	6
5.4	FILTERS.....	6
5.5	HEATLESS AIR DRYER, CAPACITY CONTROL VALVE, CHECK VALVE.....	6
5.6	PRESSURE SWITCH & UNLOADER.....	6
5.7	OUTLET PRESSURE REGULATOR and GAUGE.....	6
5.8	ELECTRICAL SYSTEM.....	6
5.9	LOW FLOW BLEED VALVE.....	6
6.0	MAINTENANCE .....	7
6.1	SIX MONTH MAINTENANCE AND INSPECTION .....	7
6.2	ANNUAL MAINTENANCE AND INSPECTION.....	7
6.3	AIR COMPRESSOR CUP SEAL REPLACEMENT .....	7
6.4	REPLACEMENT OF THE INTAKE MUFFLER FILTER ELEMENT.....	7
Figure 2	- Wiring Diagram for Standard Unit .....	8
Figure 3	- Parts Index.....	9
Figure 3	- Parts Index (cont'd).....	10



**WARNING:**

This product can expose you to chemicals including Lead, which is known to the State of California to cause cancer/birth defects or other reproductive harm. For more information go to [www.P65Warnings.ca.gov](http://www.P65Warnings.ca.gov)

## 1.0 GENERAL

- 1.1 This manual covers the specifications, installation, start-up, operation, component description, parts list, air flow schematic, wiring diagram and maintenance procedures for the model CDA10/CDA10-2 Clean Dry Air Package. This unit was designed to provide a continuous dry air flow at adjustable pressures of 0 - 75 PSIG for continuous feed systems requiring clean, dry air.
- 1.2 The air dryer carries a One Year Warranty against defective workmanship and materials starting from the date of shipment. Only parts are covered, labor to replace defective parts is not covered by this warranty. All units are tested and inspected before shipment. Any damages incurred in transit should be reported to the carrier immediately upon receipt. The manufacturer is not responsible for damage caused during shipment.

## 2.0 SPECIFICATIONS

<b>PART NUMBER</b>	CDA10, CDA10-2
<b>NORMAL OUTPUT CAPACITY</b>	5 SLPM
<b>MAXIMIUM OUTPUT CAPACITY</b>	10 SLPM
<b>COMPRESSOR MOTOR</b>	1/4 HP
<b>DELIVERED DEWPOINT</b>	-100°F (-73°C) @ atmospheric pressure
<b>DELIVERED AIR PRESSURE</b>	Standard:      Adjustable, 0-75 PSIG
<b>POWER REQUIREMENTS</b>	CDA10:      115 Volts, Single Phase, 50/60 Hz CDA10-2    230 Volts, Single Phase, 50/60 Hz.
<b>OPERATING TEMPERATURES</b>	Minimum:    33°F (1°C) Normal:     70°F (21°C) Maximum:   120°F (49°C)
<b>WEIGHT</b>	72 LBS
<b>DIMENSIONS</b>	Width:       24" Depth:      16.25" Height:      15"

### **3.0 INSTALLATION AND START-UP PROCEDURES**

- 3.1** Use the handles on the air dryer to lift and move it. Rubber feet are provided for floor mounting. The unit should be located in a well-ventilated area which will allow for suitable air circulation through the cabinet.
- 3.2** The package is designed to operate from a single phase, 60 Hz AC power supply. Connect the power cord supplied with the unit to a suitable power supply with a 15 Amp fuse. (If unit is 230 VAC, you will need to supply plug to power cord)
- 3.3** Remove the plastic plug from the low-pressure outlet and the drain outlet located on the lower left side of the unit. Connect the air outlet to the application using 1/4" OD tubing and the 1/4 NPT x 1/4" push-in elbow supplied. There is a second 1/4 NPT X 3/8" push-in elbow supplied which can be used in the drain outlet to drain away condensed moisture discharge.
- 3.4** Move the On/Off Circuit breaker switch to the "ON" Position. When power is supplied to the unit, the system will build pressure and should begin to supply dry air to the air outlet port.
- 3.5** The outlet pressure can be adjusted using the outlet pressure regulator located on the front door. Pull the knob on the regulator straight out to un-lock it. Turn the knob counterclockwise to decrease and clockwise to increase the outlet air pressure. Push in on the knob to lock it.
- 3.6** The moisture indicator on the front door will give a color-change indication of the humidity level in the outlet air. (blue is dry air, pink is moist air).
- 3.7** Once installation is complete and the start-up procedure has been performed, test for leaks at all external air connections. Operate the unit for 24 hours and repeat the start-up procedure.

### **4.0 PRINCIPLES OF OPERATION**

- 4.1** An air flow diagram of the air dryer is shown in figure 1. The basic system supplying the dry outlet air includes an air compressor, a pre-cooler, a heatless air dryer, air storage tank and outlet regulator.
- 4.2** Ambient air is drawn in through the intake filter into the air compressor where it is compressed to 80-100 PSIG. The hot, moist air then flows first through a pulsation eliminator and second into the aftercooler, to reduce the air temperature and then into the coalescing pre-filter where liquid moisture is removed and discharged to the drain outlet.
- 4.3** The liquid-free air then enters the desiccant air dryer where most of the remaining water in vapor form is removed. The dry air flows into the air storage tank that is monitored by the pressure switch which turns on and off the air compressor to maintain pressure between 80 and 100 PSIG in the tank. Air moves from the tank to the outlet pressure regulator and to the air outlet located on the left side of the cabinet.

## 5.0 COMPONENT DESCRIPTION

Figure 1 - Air Flow Diagram

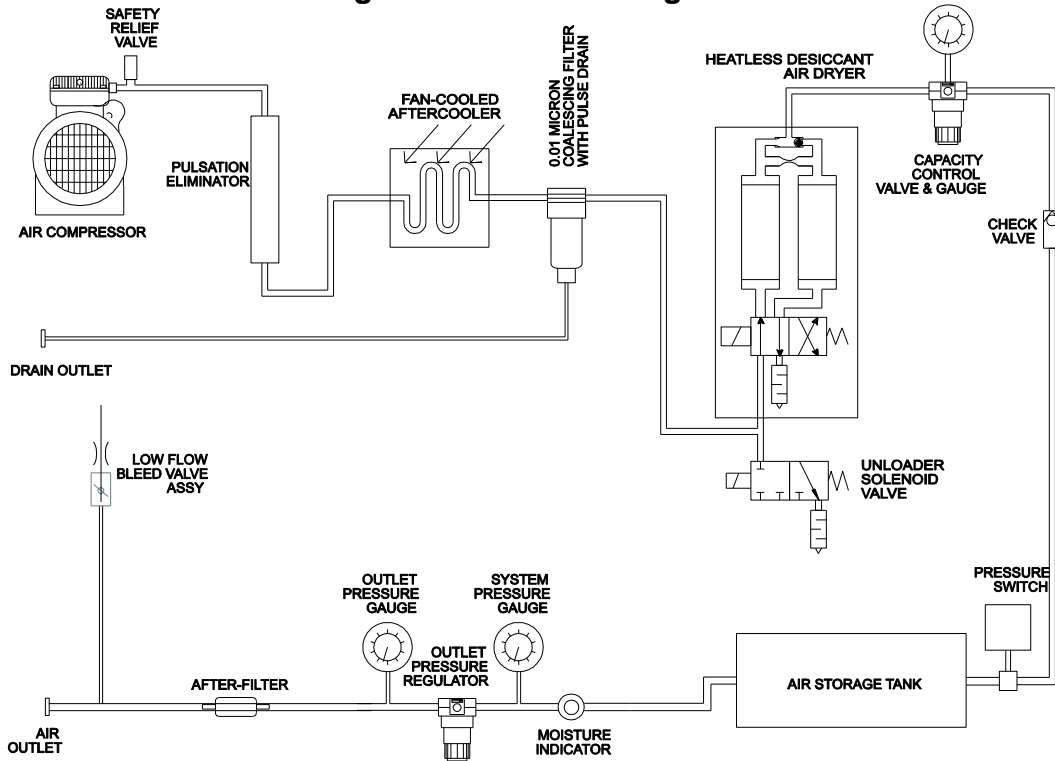

### 5.1 CABINET

- 5.1.1 The cabinet of the air dryer is ventilated to pull air in over the aftercooler and air compressor and out the side of the cabinet.
- 5.1.2 The cabinet cover can be removed for servicing the unit by removing the 8-32 machine screws.

### 5.2 AIR COMPRESSOR

- 5.2.1 The air compressor is a single cylinder, single stage, rocking piston type. The motor is equipped with built-in thermal overload protection. If the overload shuts down the compressor due to a thermal overload, the motor will automatically reset after cooling down.
- 5.2.2 An air intake filter is mounted in the inlet of the cylinder head. The air intake filter should be replaced at least every six months. See section 6.
- 5.2.3 A safety relief valve is installed in the air compressor head to prevent the pressure in the compressor from building to more than 125 PSIG.
- 5.2.4 The air compressor is mounted to a vibration plate which isolates the vibration of the compressor from the cabinet and allows for easy removal of the compressor for service.

### **5.3 VENTILATING FAN**

- 5.3.1 The ventilating fan is mounted on right side of the cabinet directly above the air compressor head. Air is drawn through the side of the cabinet up over the air compressor and after cooler and exhausted out the left side of the cabinet. Remove the cover panel for access to the ventilating fan.

### **5.4 FILTERS**

- 5.4.1 The pre-filter, located before the desiccant dryer, removes the liquid moisture condensed by the cooling of the air in the after cooler and discharge the moisture out the drain outlet.
- 5.4.2 The after-filter, located before the dry air outlet port, removes any particulates created by the operation of the desiccant dryer.

### **5.5 HEATLESS AIR DRYER, CAPACITY CONTROL VALVE, CHECK VALVE**

- 5.5.1 The heatless air dryer removes virtually all moisture from the supply air through the use of desiccant and pressurization. The capacity control valve is used to maintain a minimum back pressure of 80 PSIG in the heatless air dryer. It also prevents more than the maximum outlet flow rate from flowing into the air storage tank.
- 5.5.2 A check valve prevents dry air from the air storage tank from flowing back through the heatless dryer when the compressor shuts down.

### **5.6 PRESSURE SWITCH & UNLOADER**

- 5.6.1 The pressure switch maintains the system pressure in the air storage tank by turning on the air compressor and desiccant dryer when the system pressure falls below 80 PSIG and turns them off when the system pressure reaches 100 PSIG.
- 5.6.2 The unloader solenoid valve, located at the heatless dryer inlet port, dumps any pressure in the compressor lines whenever the compressor turns off. This eliminates the air compressor from having to start up against any pressure.

### **5.7 OUTLET PRESSURE REGULATOR and GAUGE**

- 5.7.1 The outlet pressure regulator and outlet pressure gauge are mounted on the front panel. The regulator reduces the pressure of the air to the desired outlet pressure. Pull the knob straight out to un-lock and then turn the knob counterclockwise to decrease and clockwise to increase the outlet air pressure. Push the knob in to lock the setting.

### **5.8 ELECTRICAL SYSTEM**

- 5.8.1 The air dryer is designed to operate from a single phase, 60 Hz external AC power source. The on/off switch located on the lower left side of the cabinet must be in the "On" position. The circuit breaker in the switch is rated for 10 amps. Refer to Section 7, for a detailed electrical circuit diagram for the air dryer.

### **5.9 LOW FLOW BLEED VALVE**

- 5.9.1 The low flow bleed valve is designed to bleed a small amount of dry air, putting a minimum load on the system. The valve should be opened only if there is an extremely small amount of usage at the application, or if the output of the system is dead headed.

## 6.0 MAINTENANCE

To extend the life of the air dryer and assure continued satisfactory operation, it is recommended that the following inspection and maintenance procedures be performed at the scheduled intervals.

### 6.1 SIX MONTH MAINTENANCE AND INSPECTION

Perform the following every six months or at 2200-hour intervals.

- Replace the air compressor intake filter. (section 6.4)
- Check the air compressor vibration mounts.
- Check the operation of the ventilating fan.
- Check the system pressure switch setting. (section 5.5)

### 6.2 ANNUAL MAINTENANCE AND INSPECTION

Perform the following once every year or at 4400-hour intervals:

- Perform the six-month maintenance and inspection procedures. (Section 6.1)
- Replace the inlet-filter element, P/N PS446.
- Replace the after-filter element, P/N 51898.
- Install an air compressor cup seal kit. (section 6.3)

### 6.3 AIR COMPRESSOR CUP SEAL REPLACEMENT

Before performing any repairs or maintenance on the air dryer make sure that the start-stop switch is off and disconnect the external power supply to the unit. Refer to the instructions provided with the Cup Seal Replacement Kit, 100519603 and perform the procedure to replace the cylinder, cylinder gasket, O-ring and cup seals provided in the kit.

### 6.4 REPLACEMENT OF THE INTAKE MUFFLER FILTER ELEMENT

- 6.4.1 Remove the intake Muffler by turning counterclockwise.
- 6.4.2 Discard the spent intake Muffler and replace it with the new one.
- 6.4.3 Install the Intake Muffler by turning it clockwise.

Figure 2 – Wiring Diagram for Standard Unit

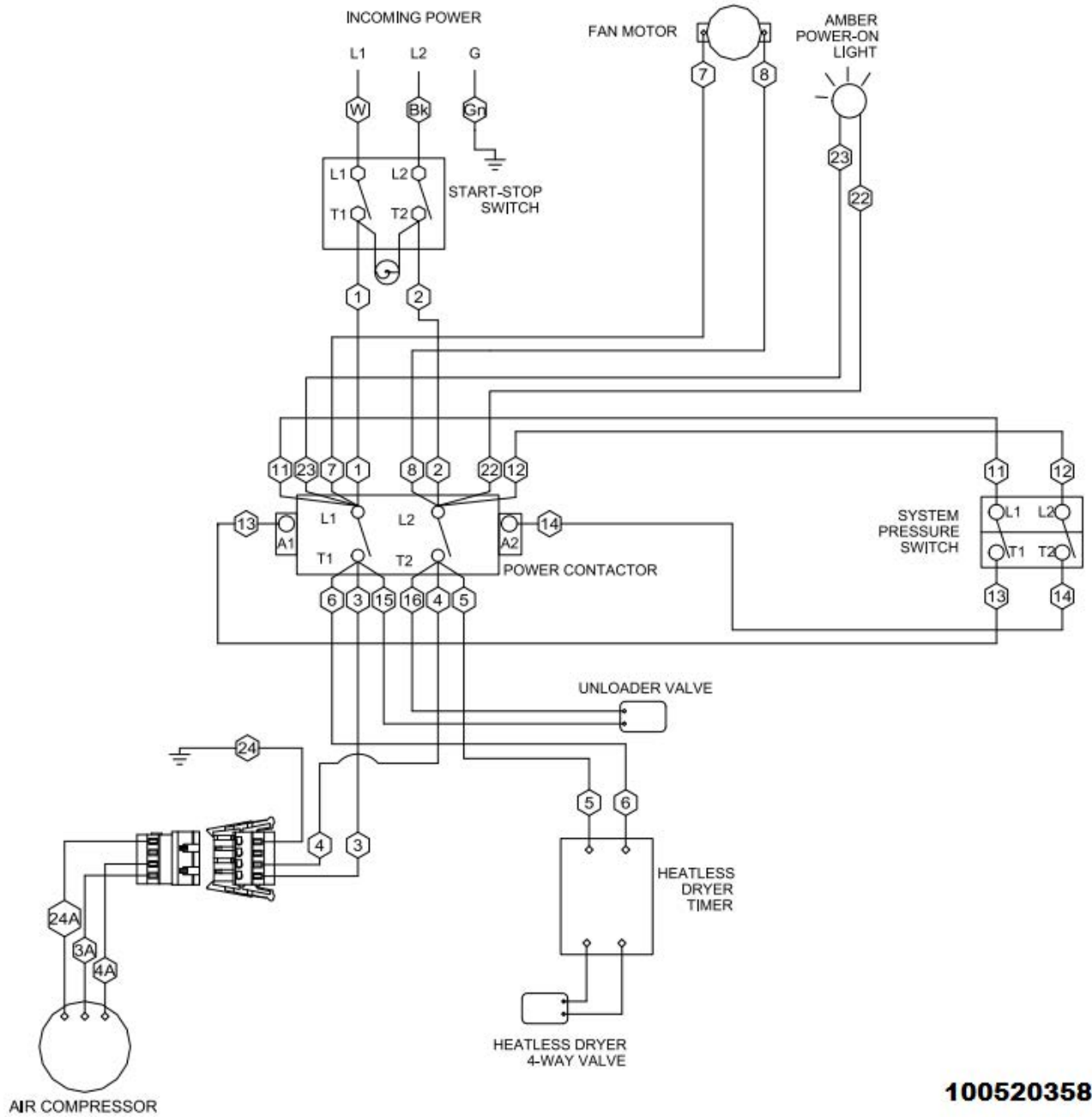
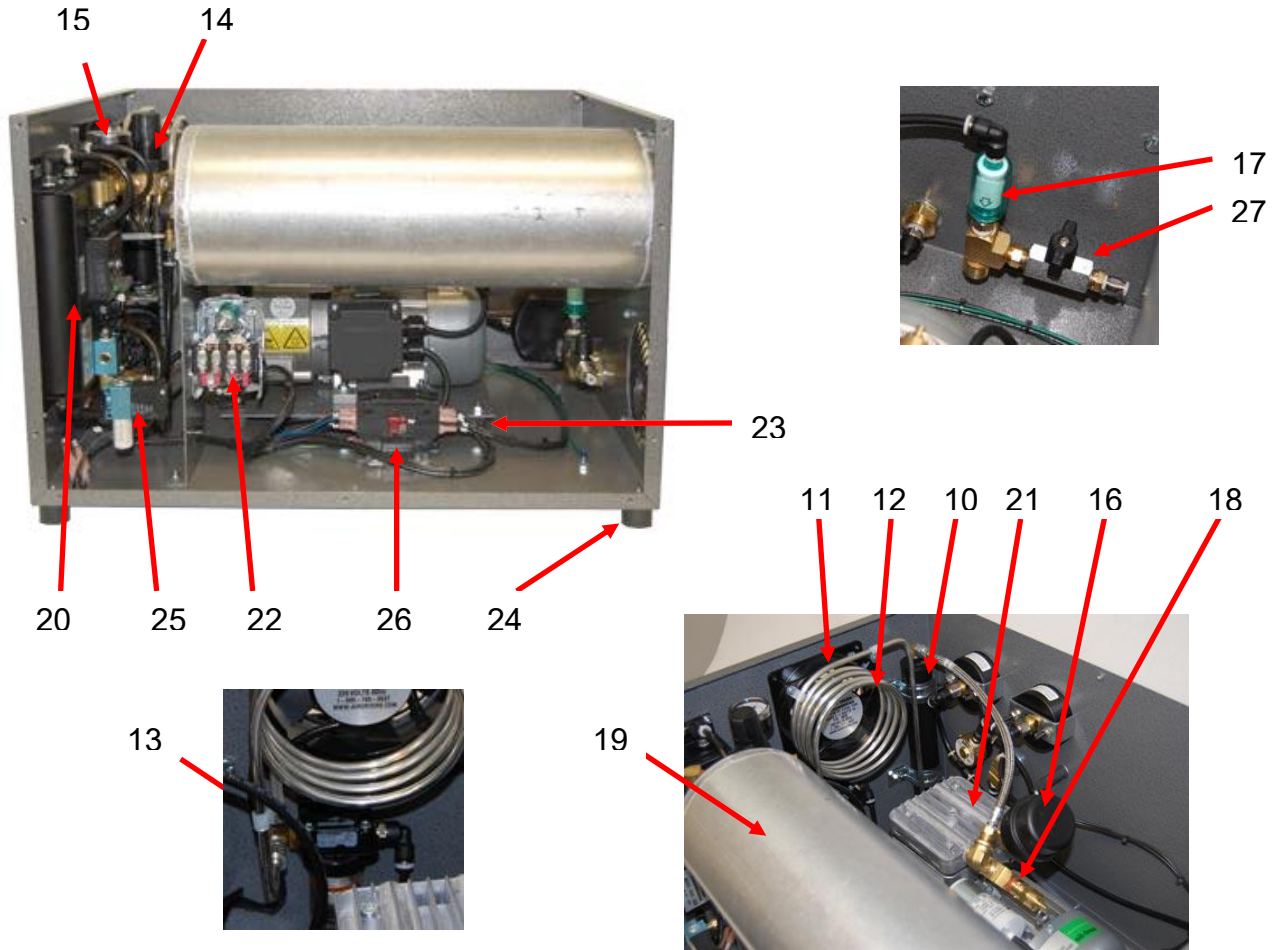

**Figure 3 - Parts Index**



REF NO.	DESCRIPTION	Model CDA10
1	SYSTEM PRESSURE GAUGE (0-160 PSIG)	9530
2	OUTLET PRESSURE GAUGE (0-100 PSIG)	7949
3	POWER "ON" LAMP	11785 (115V) 7967 (220V)
4	OUTLET PRESSURE REGULATOR (0-125 PSIG)	9623
5	MOISTURE INDICATOR	51356
6	HANDLE	51755
7	AIR OUTLET	11180
8	DRAIN OUTLET	11180
9	"ON/OFF" POWER CIRCUIT BREAKER	51745
10	GRILLE / FAN GUARD	9523

Figure 3 - Parts Index (cont'd)



REF NO.	DESCRIPTION	Model CDA10
10	PULSATION ELIMINATOR	7948
11	VENTILATING FAN	FAN 9522 (115V) 9528 (230V)
12	AFTERCOOLER	51764
13	PREFILTER	M03-02-D00 ELEMENT PS446
14	CAPACITY CONTROL VALVE	51126
15	CAPACITY CONTROL VALVE GAUGE	3197
16	COMPRESSOR AIR INTAKE FILTER	100508744
17	AFTER-FILTER	51898
18	SAFETY RELIEF VALVE	9632
19	AIR STORAGE TANK	9865
20	DESICCANT AIR DRYER	MDH3-AHE-S46 (115V) MDH3-DHE-S46 (230V)
21	AIR COMPRESSOR & AIR HOSE	100520091 (115V) 100504425 (230V) HOSE 7567
22	PRESSURE SWITCH	9659
23	COMPRESSOR VIBRATION MOUNTS	51748
24	CABINET VIBRATION MOUNTS	7286
25	UNLOADER VALVE	7503 (115V) 7511 (230V)
26	POWER CONTACTOR	11247 (115V) 7475 (230V)
27	LOW FLOW BLEED VALVE ASSY	8296